

PROJECT ID: 6355-00-74
WITH: N/A

COUNTY: ADAMS

STATE OF WISCONSIN DEPARTMENT OF TRANSPORTATION

PLAN OF PROPOSED IMPROVEMENT

CTH H - CTH F EDGEWOOD AVENUE TO CTH F CTH Z ADAMS COUNTY

STATE PROJECT NUMBER
6355-00-74

STATE PROJECT	FEDERAL PROJECT	
	PROJECT	CONTRACT
6355-00-74		

ORDER OF SHEETS

Section No.	Title
1	Typical Sections and Details
2	Estimate of Quantities
3	Miscellaneous Quantities
4	Right of Way Plat
5	Plan and Profile
6	Standard Detail Drawings
7	Sign Plates
8	Structure Plans
9	Computer Earthwork Data
9	Cross Sections

TOTAL SHEETS =

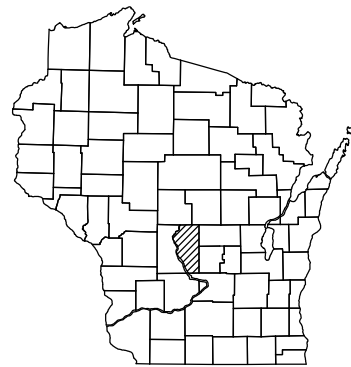

DESIGN DESIGNATION

A.A.D.T. (2016)	=	2300
A.A.D.T. (2030)	=	2950
D.H.V. (2030)	=	393
D.D.	=	60/40
T.	=	6%
DESIGN SPEED	=	55 MPH
ESALS	=	474,500

CONVENTIONAL SYMBOLS

PLAN	PROFILE
CORPORATE LIMITS	GRADE LINE
PROPERTY LINE	ORIGINAL GROUND
LOT LINE	MARSH OR ROCK PROFILE (To be noted as such)
LIMITED HIGHWAY EASEMENT	SPECIAL DITCH
EXISTING RIGHT OF WAY	GRADE ELEVATION
PROPOSED OR NEW R/W LINE	CULVERT (Profile View)
SLOPE INTERCEPT	UTILITIES
REFERENCE LINE	ELECTRIC
EXISTING CULVERT	FIBER OPTIC
PROPOSED CULVERT (Box or Pipe)	GAS
COMBUSTIBLE FLUIDS	SANITARY SEWER
MARSH AREA	STORM SEWER
WOODED OR SHRUB AREA	TELEPHONE
	WATER
	UTILITY PEDESTAL
	POWER POLE
	TELEPHONE POLE

END PROJECT
STA 649+40.07

BEGIN PROJECT
STA 481+00.00
Y = 185365.787
X = 499267.995

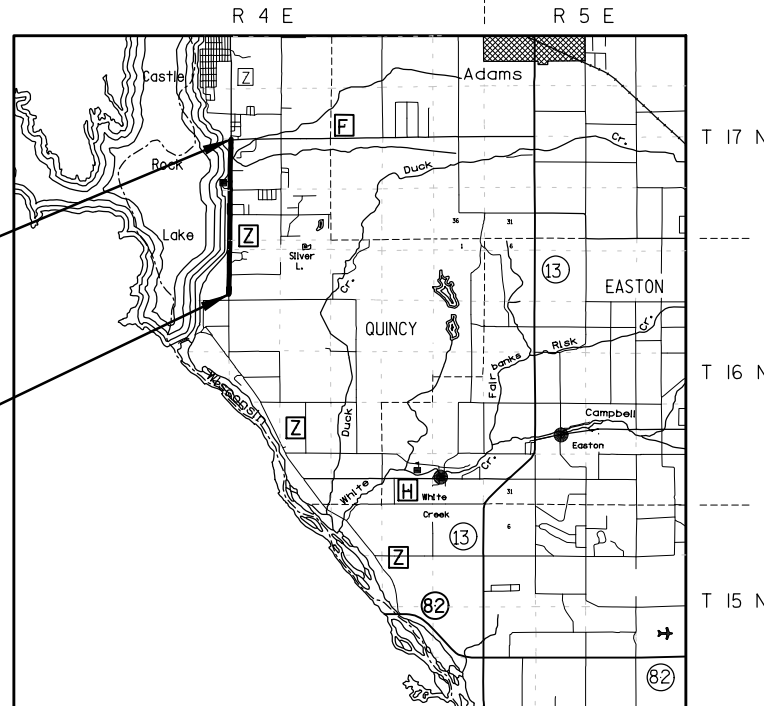

LAYOUT
SCALE 0 1 MI.

TOTAL NET LENGTH OF CENTERLINE = 3.189

HORIZONTAL POSITIONS SHOWN ON THIS PLAN ARE WISCONSIN COUNTY COORDINATE SYSTEM (WCCS), ADAMS COUNTY, NAD83 (1991), IN U.S. SURVEY FEET. POSITIONS SHOWN ARE GRID COORDINATES, GRID BEARINGS, AND GRID DISTANCES. GRID DISTANCES ARE THE SAME AS GROUND DISTANCES. ELEVATIONS ARE REFERENCED TO NAVD 88 (1991).

ACCEPTED FOR
COUNTY of ADAMS
DATE:

ORIGINAL PLANS PREPARED BY:



STATE OF WISCONSIN
DEPARTMENT OF TRANSPORTATION

PREPARED BY
Surveyor _____ SEH
Designer _____ SEH
Project Manager _____ PROJECT MANAGER
Regional Examiner _____ REGIONAL EXAMINER
Regional Supervisor _____ REGIONAL SUPERVISOR

APPROVED FOR THE DEPARTMENT
DATE: _____ (Signature)

E

STANDARD ABBREVIATIONS

ABUT	ABUTMENT
AC	ACRE
AGG	AGGREGATE
AECPRC	APRON ENDWALL FOR CULVERT PIPE REINFORCED CONCRETE
ASPH	ASPHALTIC
AVG	AVERAGE
ADT	AVERAGE DAILY TRAFFIC
BF	BACK FACE
BM	BENCH MARK
BR	BRIDGE
CE	COMMERCIAL ENTRANCE
CL OR C/L OR ϵ	CENTER LINE
	CENTER ANGLE OR DELTA
CONC	CONCRETE
CPRC	CULVERT PIPE REINFORCED CONCRETE
CPRCHE	CULVERT PIPE REINFORCED CONCRETE HORIZONTAL ELLIPTICAL
CR	CREEK
CSACP	CORRUGATED STEEL ARCH CULVERT PIPE
CSCP	CORRUGATED STEEL CULVERT PIPE
CY	CUBIC YARD
C & G	CURB AND GUTTER
D	DEGREE OF CURVE
DHV	DESIGN HOUR VOLUME
DISCH	DISCHARGE
DG	DITCH GRADE
DWY	DRIVEWAY
X	EAST GRID COORDINATE
EAT	STEEL PLATE BEAM GUARD
	ENERGY ABSORBING TERMINAL
EOR	END POINT OF RADIUS
EL	ELEVATION
ENT	ENTRANCE
ESALS	EQUIVALENT SINGLE AXLE LOADS
EXC	EXCAVATION
EBS	EXCAVATION BELOW SUBGRADE
EXIST	EXISTING
FC	FACE OF CURB
FF	FACE TO FACE
FERT	FERTILIZE
FE	FIELD ENTRANCE
FL	FLOW LINE
FO	FIBER OPTIC
CWT	HUNDREDWEIGHT
HYD	HYDRANT
ID	INSIDE DIAMETER
INV	INVERT
IP	IRON PIPE ON PIN
LHF	LEFT-HAND FORWARD
L	LENGTH OF CURVE
LF	LINEAR FOOT
LC	LONG CHORD OF CURVE
LS	LUMP SUM
MH	MANHOLE
MOR	MID POINT OF RADIUS
NC	NORMAL CROWN
NO	NUMBER
OBLIT	OBLITERATE
PAVT	PAVEMENT
PE	PRIVATE ENTRANCE
PVRC	POINT OF VERTICAL REVERSE CURVE
QOR	QUARTER POINT OF RADIUS
R	RADIUS
REQ'D	REQUIRED
RES	RESIDENCE OR RESIDENTIAL
RHF	RIGHT-HAND FORWARD
R/W	RIGHT-OF-WAY
R	RIVER
RDWY	ROADWAY
R/L OR ϵ	REFERENCE LINE
SALV	SALVAGED
SAN	SANITARY SEWER
SF	SQUARE FEET
SY	SQUARE YARD
SDD	STANDARD DETAIL DRAWINGS
SDLT	SPECIAL DITCH LEFT
SDRT	SPECIAL DITCH RIGHT
STA	STATION
SS	STORM SEWER
SSPRC	STORM SEWER PIPE REINFORCED CONCRETE
SE	SUPERELEVATION RATE
TC	TOP OF CURB
T OR TN	TOWN
T	TRUCKS (PERCENT OF)
TYP	TYPICAL
VAR	VARIABLE
VC	VERTICAL CURVE
Y	NORTH GRID COORDINATE
YD	YARD

GENERAL NOTES

ELEVATIONS SHOWN ON THE PLAN ARE REFERENCED TO THE NGVD29. FOUND STANDARD DISK IN CONCRETE POST SET FLUSH WITH THE GROUND, STAMPED ET 19 GT 1959 868, 7.5 MILES SOUTH OF DELLWOOD AT THE LINCOLN TOWN HALL, T16N, R5E, NEAR THE SE CORNER OF SECTION 7, 124 FT NORTH AND 31 FEET WEST AND 0.7' LOWER THEN CROSS ROAD, ELEV 867.53.

WHEN THE QUANTITY OF BASE AGGREGATE IS MEASURED FOR PAYMENT BY THE TON, THE DEPTH OR THICKNESS OF THE LAYER SHOWN ON THE PLANS IS APPROXIMATE AND THE ACTUAL THICKNESS WILL DEPEND ON THE DISTRIBUTION OF THE MATERIAL AS DIRECTED BY THE ENGINEER.

THE LOCATION OF EXISTING AND PROPOSED UTILITY INSTALLATIONS AS SHOWN ON THE PLANS IS APPROXIMATE. THERE MAY BE OTHER UTILITY INSTALLATIONS WITHIN THE PROJECT AREA THAT ARE NOT SHOWN.

NO TREES OR SHRUBS ARE TO BE REMOVED WITHOUT THE APPROVAL OF THE ENGINEER.

THE EXACT LOCATION OF THE EROSION CONTROL DEVICES SHALL BE DETERMINED IN THE FIELD.

DISTURBED AREAS WITHIN THE RIGHT-OF-WAY, EXCEPT THE AREAS WITHIN THE FINISHED SHOULDER POINTS, ARE TO BE 4-INCH SALVAGED TOPSOILED OR TOPSOILED, FERTILIZED, AND SEEDED AND MULCHED. FINISHED SEEDED SURFACE SHALL BE 1-INCH BELOW THE TOP OF ADJACENT CONCRETE.

THE LOCATION OF ALL DRIVEWAYS WILL BE DETERMINED BY THE ENGINEER.

ALL CURB AND GUTTER RADII, PAVEMENT DIMENSIONS AND STATIONS ARE SHOWN TO THE EDGE OF PAVEMENT UNLESS NOTED OTHERWISE.

ALL SIDE ROAD EARTHWORK QUANTITIES ARE INCLUDED IN MAINLINE EARTHWORK QUANTITIES.

A VERTICAL SAWCUT SHALL BE MADE THROUGH EXISTING DRIVEWAYS AND PAVEMENTS AT REMOVAL LIMITS.

TOP OF CASTING ELEVATIONS SHOWN FOR INLETS REFER TO THE CASTING ELEVATION AT THE FLOWLINE OF GRATE.

ALL STORM SEWER INVERTS, ELEVATIONS, PIPE LENGTHS, AND GRADES ARE COMPUTED CENTER-TO-CENTER OF STRUCTURES.

EXCAVATION BELOW SUBGRADE (EBS) IS NOT USED TO BALANCE YARDAGE AND IS NOT SHOWN ON THE CROSS SECTIONS BUT IS MEASURED AND PAID FOR AS COMMON EXCAVATION.

HMA PAVEMENT SHALL BE CONSTRUCTED WITH THE FOLLOWING LAYER THICKNESSES:

PAVEMENT THICKNESS (INCH)	LOWER (INCH)	NOM AGG SIZE (mm)	MIDDLE (INCH)	NOM AGG SIZE (mm)	UPPER (INCH)	NOM AGG SIZE (mm)
4.5	2.5	19.0	----	----	2.0	12.5
2.5	----	----	----	----	2.5	12.5

EXISTING PIPE CULVERT SIZES SHOWN ARE APPROXIMATE AND THE CONTRACTOR SHALL BASE ITS BID ON ACTUAL FIELD CONDITIONS.

ORDER OF SECTION 2 SHEETS

WRITTEN MATERIAL
 TYPICAL SECTIONS
 CONSTRUCTION DETAILS
 INTERSECTION DETAILS
 EROSION CONTROL
 STORM SEWER
 PERMANENT SIGNING
 CONTROL TIES

UTILITY CONTACTS

ADAMS-COLUMBIA ELECTRIC COOP
 401 EAST LAKE ST
 PO BOX 70
 FRIENDSHIP, WI 53934-0070
 TELEPHONE: 800.831.8629 EXT. 244
 ATTENTION: JOHN GOODMAN
 EMAIL: jgoodman@ace1wi.com

DESIGN CONTACT

SEH INC.
 421 FRENETTE DR
 CHIPPEWA FALLS, WI 54729
 TELEPHONE: 715.720.6200
 ATTENTION: JOHN BECKFIELD

WDNR CONTACT

WIS DNR
 473 GRIFFITH DR
 WISCONSIN RAPIDS, WI 54494
 TELEPHONE: 715.421.7867
 ATTENTION: TONY FISCHER



FOR FIELD LOCATES
 CALL: 1.800.242.8511
 www.DiggersHotline.com

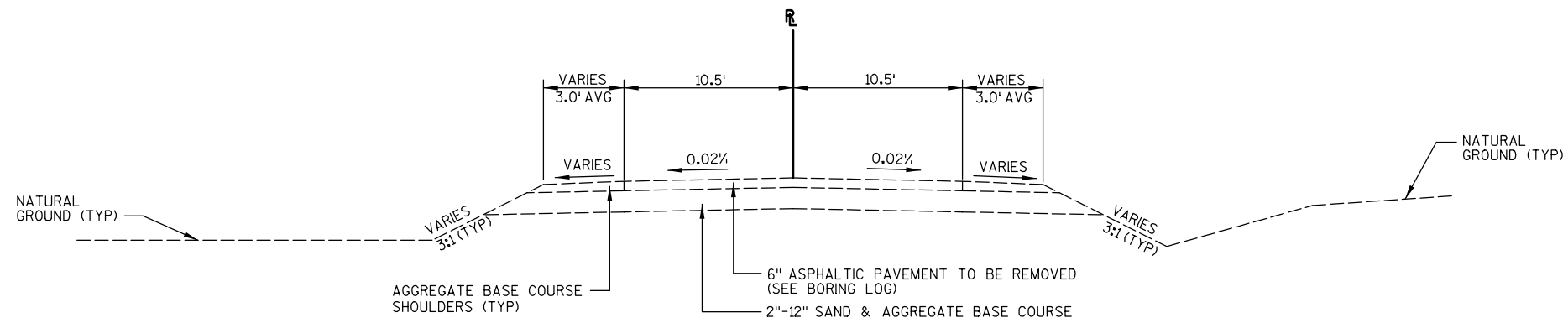

TYPICAL EXISTING SECTION
 STA 481+00.00 TO STA 649+40.07

BORING LOG				
CORE NUMBER	STATION	LOCATION	ASPHALT DEPTH IN INCHES	UNDERLAYING MATERIAL
ST-09	489+49.86	RT	6	4" BASE
ST-10	513+31.50	LT	6	4" BASE
ST-11	580+48.66	LT	6	5" BASE
ST-12	628+85.43	RT	6	10" BASE
ST-13	637+68.99	RT	6	12" BASE

NOTES:

- ① REFER TO MISCELLANEOUS QUANTITY FOR LIMITS OF SALVAGED TOPSOIL AND TOPSOIL.
- ② PLACE 4" BASE AGGREGATE DENSE 1/4" ON TOP OF EXISTING ASPHALTIC PAVEMENT TO THE LIMITS SHOWN, PRIOR TO PULVERIZING AND RELAY OPERATIONS TO OBTAIN A CONSISTENT "MIXED" BASE MATERIAL.
- ③ SLOPES VARIES FROM 6:1 TO 4:1 AT SPECIAL DITCH LOCATIONS. REFER TO CROSS SECTIONS FOR SLOPES AND DITCH WIDTHS.

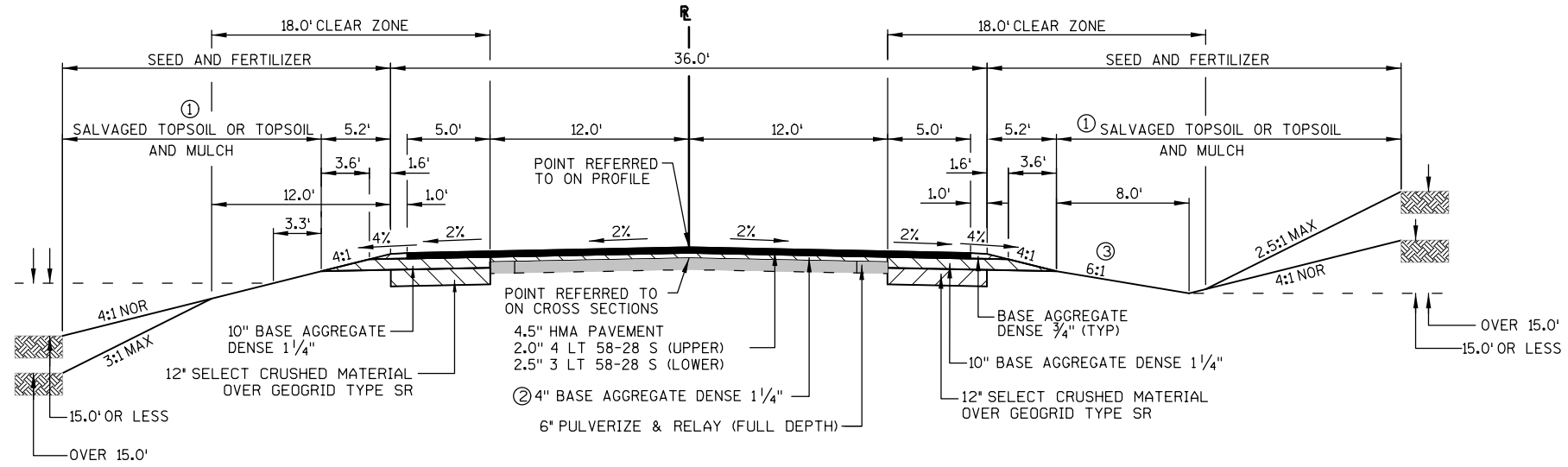

TYPICAL FINISHED RECONDITION SECTION

STA 508+00.00 TO STA 530+50.00
 STA 534+00.00 TO STA 547+00.00
 STA 555+50.00 TO STA 581+00.00
 STA 594+00.00 TO STA 599+66.48

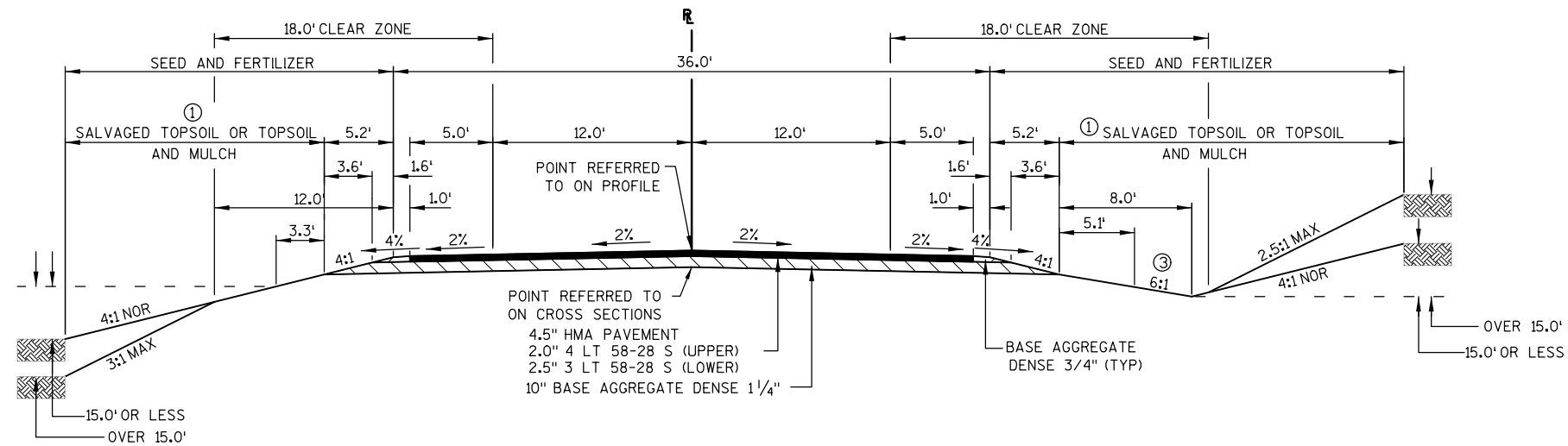

TYPICAL FINISHED RECONSTRUCTION SECTION

STA 500+00.00 TO STA 508+00.00
 STA 530+50.00 TO STA 534+00.00
 STA 547+00.00 TO STA 555+50.00
 STA 581+00.00 TO STA 594+00.00
 STA 647+00.00 TO STA 649+40.07

- NOTES:**
- ① REFER TO MISCELLANEOUS QUANTITY FOR LIMITS OF SALVAGED TOPSOIL AND TOPSOIL.
 - ② SLOPES VARIES FROM 6:1 TO 4:1 AT SPECIAL DITCH LOCATIONS. REFER TO CROSS SECTIONS FOR SLOPES AND DITCH WIDTHS.

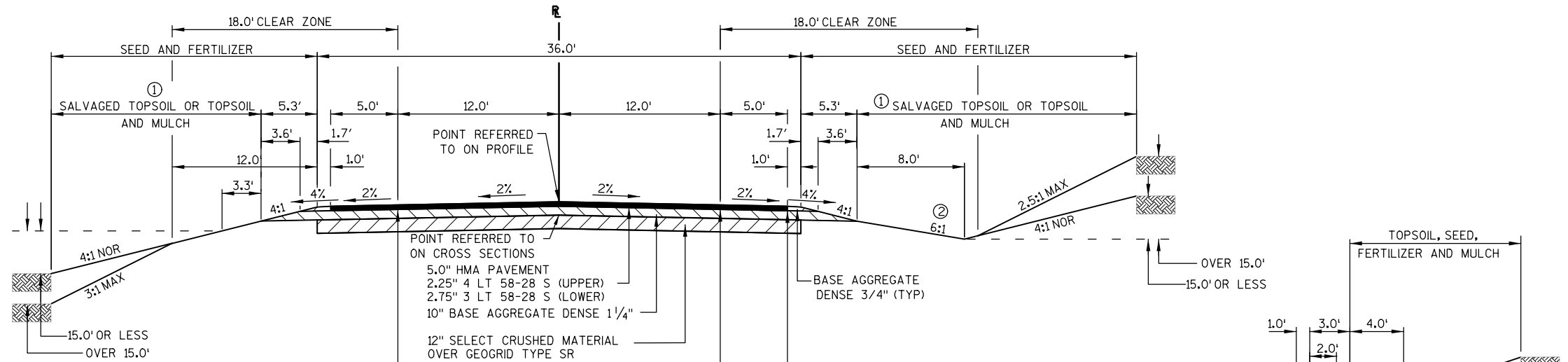

TYPICAL FINISHED RECONSTRUCTION SECTION
STA 481+00.00 TO STA 500+00.00

5.0" HMA PAVEMENT
2.25" 4 LT 58-28 S (UPPER)
2.75" 3 LT 58-28 S (LOWER)
10" BASE AGGREGATE DENSE 1 1/4"
12" SELECT CRUSHED MATERIAL
OVER GEOGRID TYPE SR
CONCRETE CURB & GUTTER
6" SLOPED 36" TYPE D

TYPICAL FINISHED SECTION
STA 495+00.00 TO STA 499+00.00

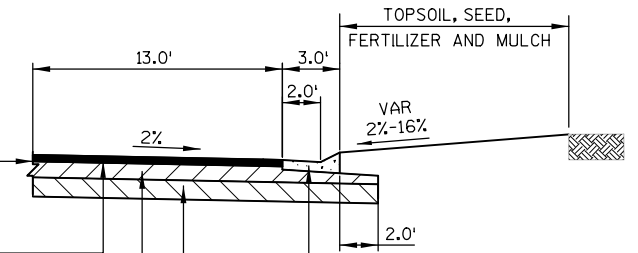

5.0" HMA PAVEMENT
2.25" 4 LT 58-28 S (UPPER)
2.75" 3 LT 58-28 S (LOWER)
10" BASE AGGREGATE DENSE 1 1/4"
12" SELECT CRUSHED MATERIAL
OVER GEOGRID TYPE SR

TYPICAL FINISHED BYPASS SECTION
STA 494+31.44 TO STA 500+42.52

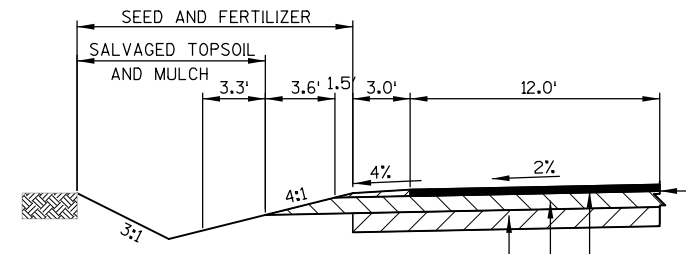

5.0" HMA PAVEMENT
2.25" 4 LT 58-28 S (UPPER)
2.75" 3 LT 58-28 S (LOWER)
10" BASE AGGREGATE DENSE 1 1/4"
12" SELECT CRUSHED MATERIAL
OVER GEOGRID TYPE SR

TYPICAL FINISHED RIGHT TURN LANE SECTION
STA 495+96.38 TO STA 499+72.45

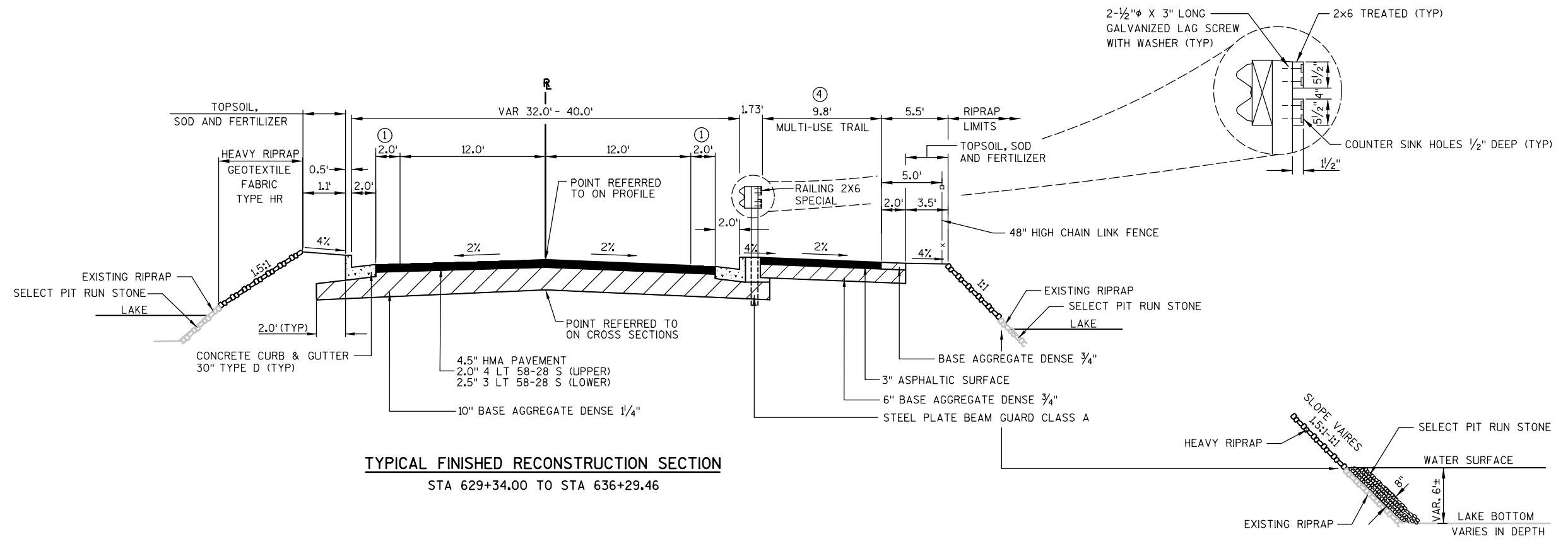

TYPICAL FINISHED RECONSTRUCTION SECTION
STA 629+34.00 TO STA 636+29.46

TYPICAL FINISHED CAUSEWAY RIPRAP SECTION

STA 630+00 TO STA 634+25 LT
STA 634+90 TO STA 637+70 LT
STA 630+15 TO STA 634+25 RT
STA 634+90 TO STA 636+00 RT

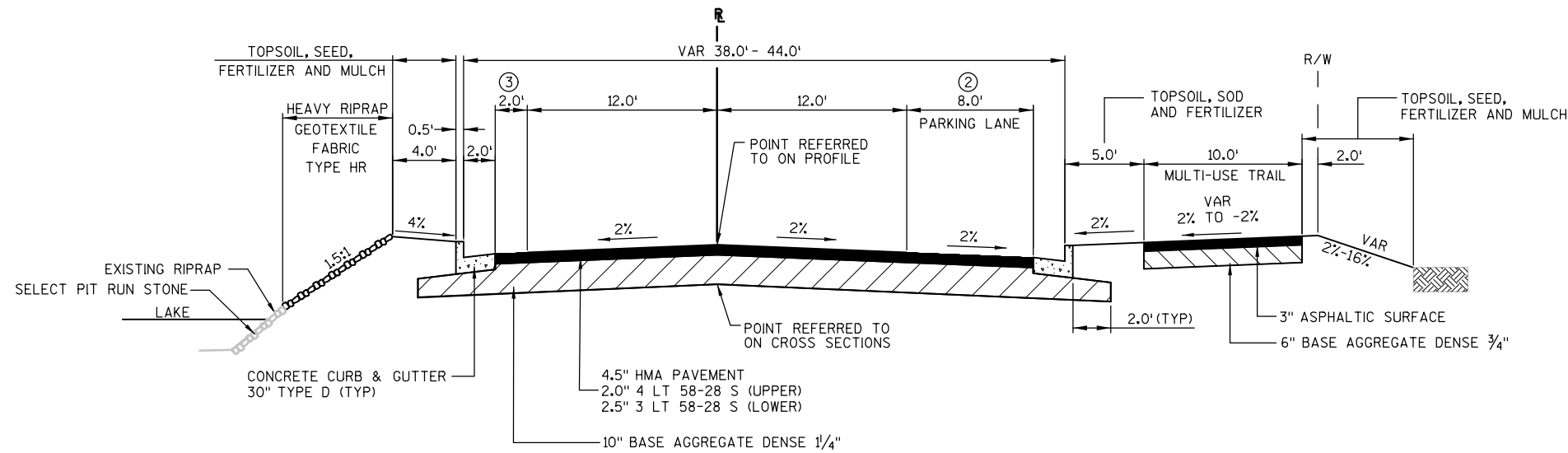

TYPICAL FINISHED RECONSTRUCTION SECTION
STA 636+29.46 TO STA 638+04.00

NOTES:

- ① WIDTH VARIES FROM 4.0' TO 2.0' FROM STA 629+34.00 TO STA 630+46.00 LEFT AND RIGHT AND FROM 2.0' TO 8.0' FROM STA 635+93.37 TO STA 636+29.46 RIGHT.
- ② CONSTRUCT 8' WIDE PARKING LANE FROM STA 635+93.37 TO STA 638+04.00 RIGHT.
- ③ WIDTH VARIES FROM 2.0' TO 8.0' FROM STA 638+04.00 TO STA 638+16.00 RIGHT.
- ④ TRANSITION MULTI-USE TRAIL WIDTH FROM 10.0' TO 5.5' TO MATCH EXISTING WALKWAY FROM: STA 633+96.40 TO STA 634+40.13 STA 634+71.10 TO STA 635+17.37

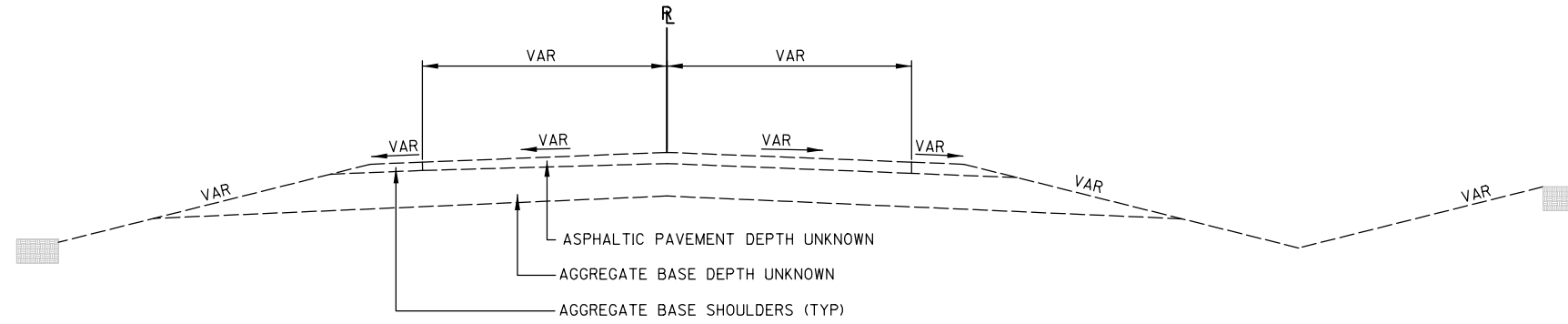

TYPICAL EXISTING SIDEROAD SECTION

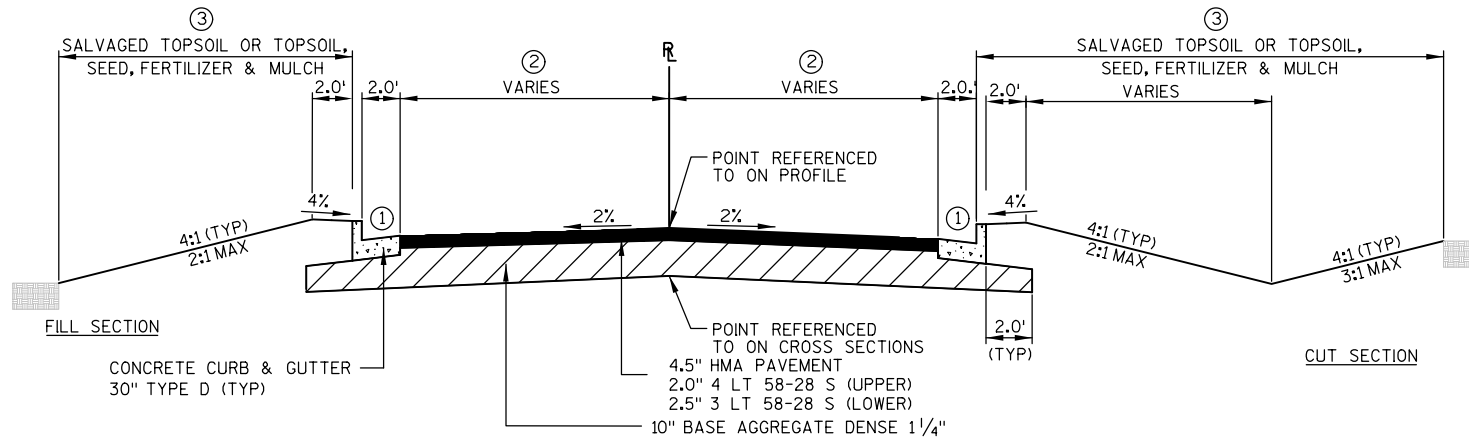

TYPICAL FINISHED SIDEROAD SECTION

STA 114+41.96 TO STA 114+82.00 (PARK EXIT)
 STA 124+38.12 TO STA 124+76.00 (PARK ENTRANCE)
 STA 130+20.00 TO STA 130+74.88 (DUCK CREEK DRIVE)

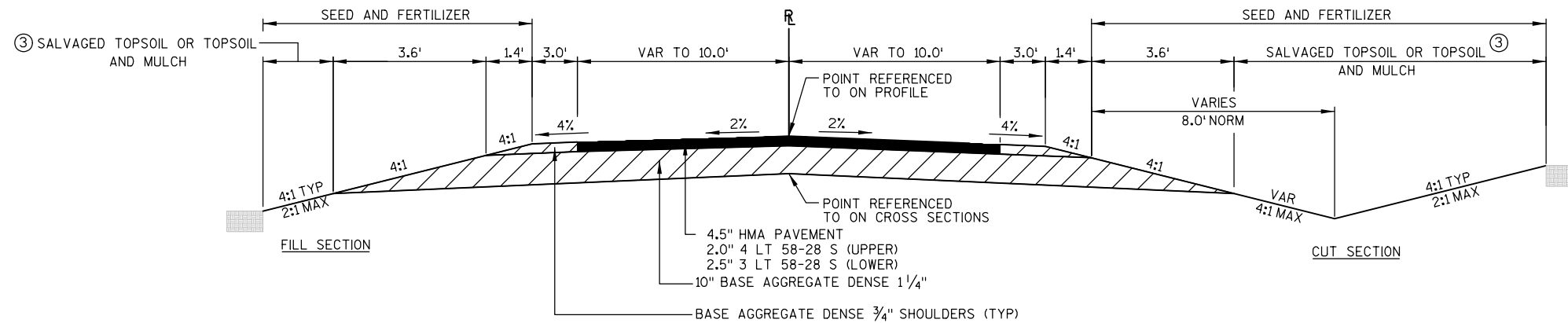

TYPICAL FINISHED SIDEROAD SECTION

STA 63+50.00 TO STA 64+82.00 (EDGEWOOD AVENUE)
 STA 65+82.00 TO STA 66+50.00 (EDGEWOOD AVENUE)
 STA 68+90.00 TO STA 69+82.00 (LAKES EDGE LANE)
 STA 75+18.00 TO STA 76+50.00 (EAGLE DRIVE)
 STA 80+18.00 TO STA 81+30.00 (EAGLE COURT)
 STA 85+18.00 TO STA 86+35.00 (EAGLE AVENUE)
 STA 105+18.00 TO STA 106+50.00 (DYKE DRIVE)
 STA 110+18.00 TO STA 111+65.00 (LAKEVIEW DRIVE)
 STA 113+75.00 TO STA 114+41.96 (PARK EXIT)
 STA 120+22.00 TO STA 121+50.00 (DYKE AVENUE)
 STA 123+50.00 TO STA 124+38.12 (PARK ENTRANCE)
 STA 130+74.88 TO STA 131+50.00 (DUCK CREEK DRIVE)

NOTES:

- ① USE CONCRETE CURB & GUTTER 6" SLOPED 36" TYPE D ON PARK EXIT AND PARK ENTRANCE.
- ② REFER TO STANDARD DETAIL DRAWINGS AND INTERSECTION DETAIL SHEETS FOR WIDTHS.
- ③ REFER TO MISCELLANEOUS QUANTITY FOR LIMITS OF SALVAGED TOPSOIL AND TOPSOIL.

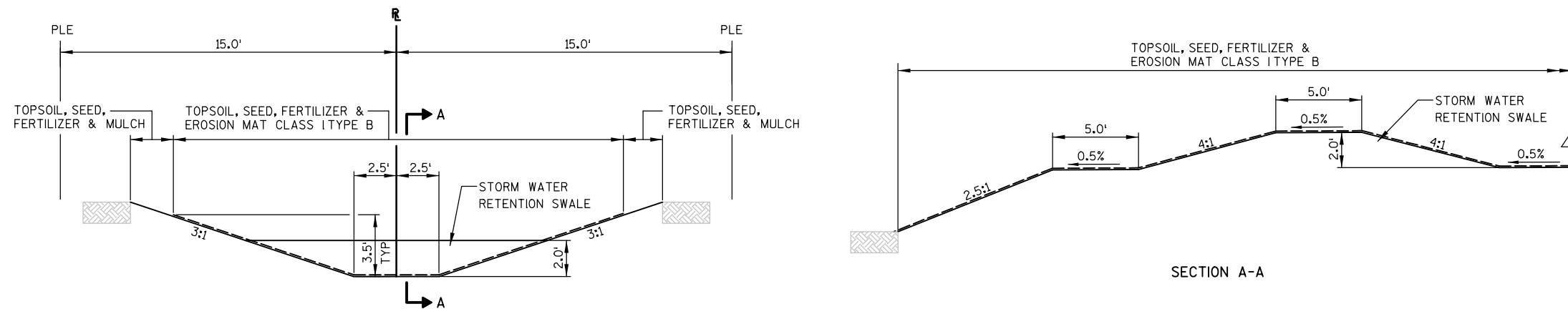

TYPICAL FINISHED DITCH SECTION

STA 88+94.00 TO STA 89+64.64 (OUTFALL 1)
 STA 93+94.00 TO STA 94+66.14 (OUTFALL 2)
 STA 98+97.00 TO STA 99+60.24 (OUTFALL 3)

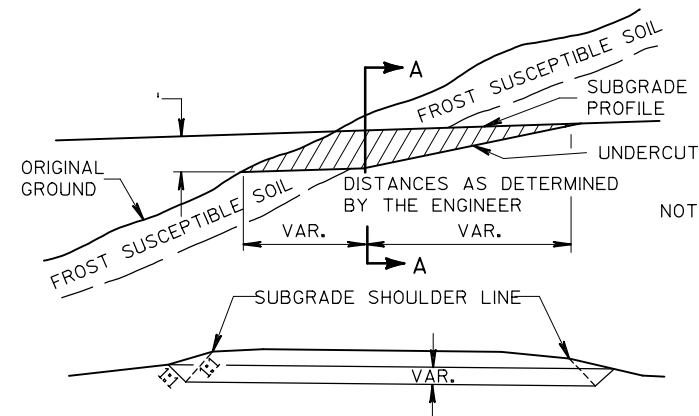

SECTION A-A
CROSS SECTION SHOWING UNDERCUT
DETAIL FOR EXCAVATION BELOW
SUBGRADE AT CUTS

NOTE: EXACT LOCATIONS AND EXTENT OF E.B.S. SECTIONS SHALL BE DETERMINED BY THE ENGINEER IN THE FIELD. E.B.S. AREA TO BE BACKFILLED WITH MATERIAL ACCEPTABLE TO THE ENGINEER. BACKFILL MUST BE HOMOGENEOUS WITH ADJOINING FILL MATERIAL. THE FILL SECTION WITHIN 100' OF THE MOUTH OF THE CUT MUST BE KEPT 2' BELOW SUBGRADE UNTIL E.B.S. IS COMPLETED.

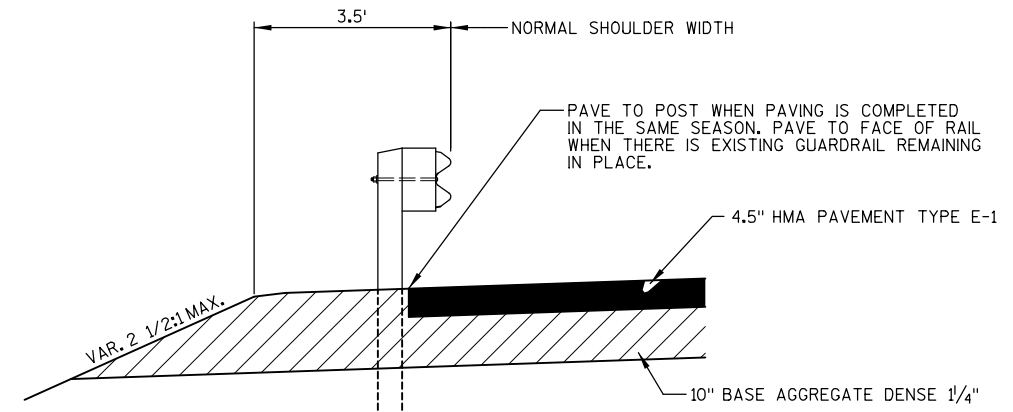

SECTION A-A
SHOULDER DETAIL AT BEAM GUARD

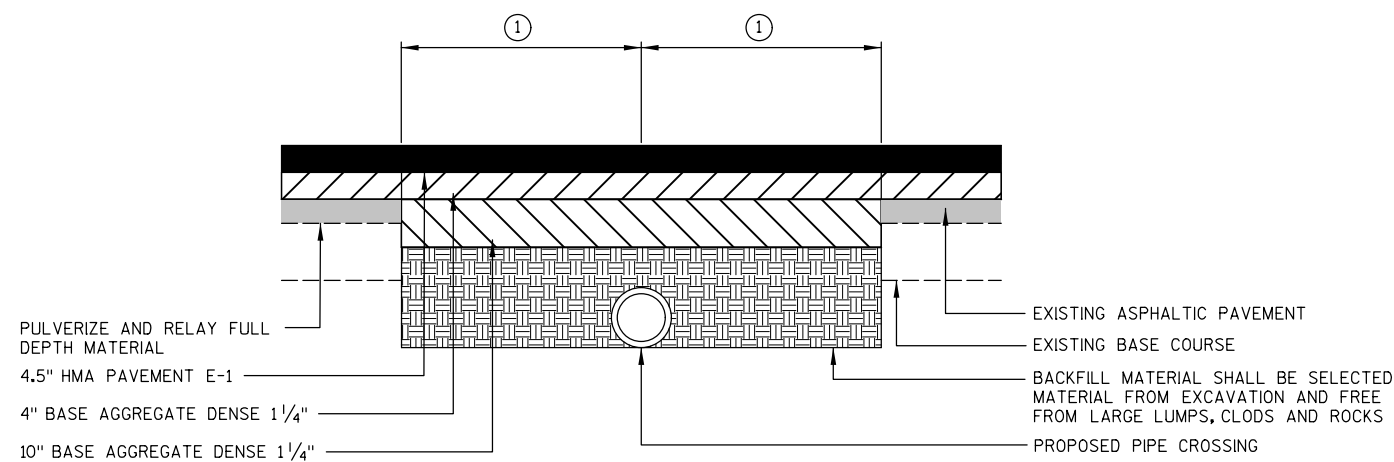

TYPICAL PIPE CROSSING IN RECONDITION SECTIONS

STA 107+18	STA 301+00
STA 113+70	STA 472+00
STA 153+00	STA 509+00
STA 205+50	STA 539+00
STA 224+78	STA 557+50
STA 279+00	STA 570+70
STA 289+75	STA 597+30

NOTES:

① 10.0' OR AS DIRECTED BY THE ENGINEER IN THE FIELD.

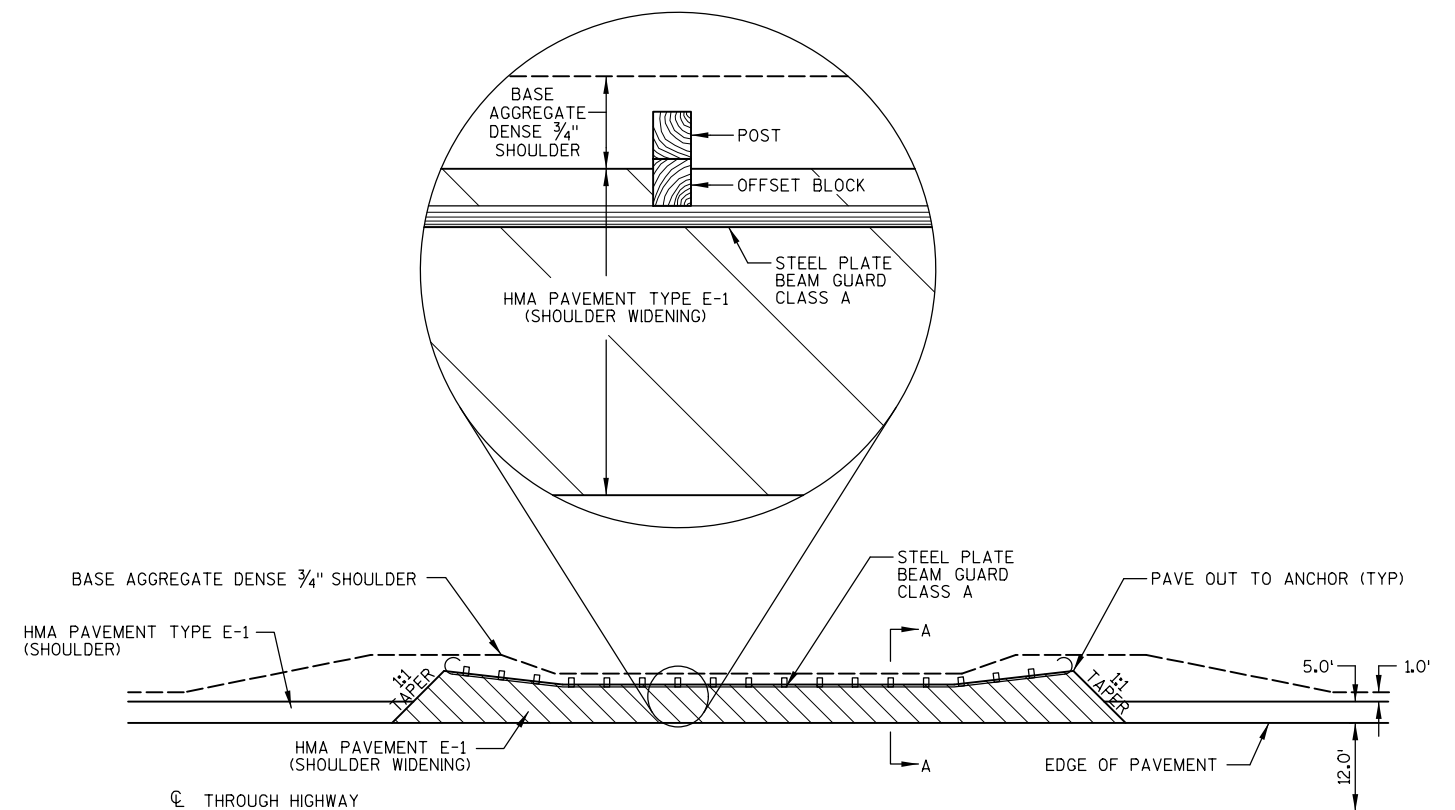

ASPHALTIC PAVING ALONG BEAM GUARD

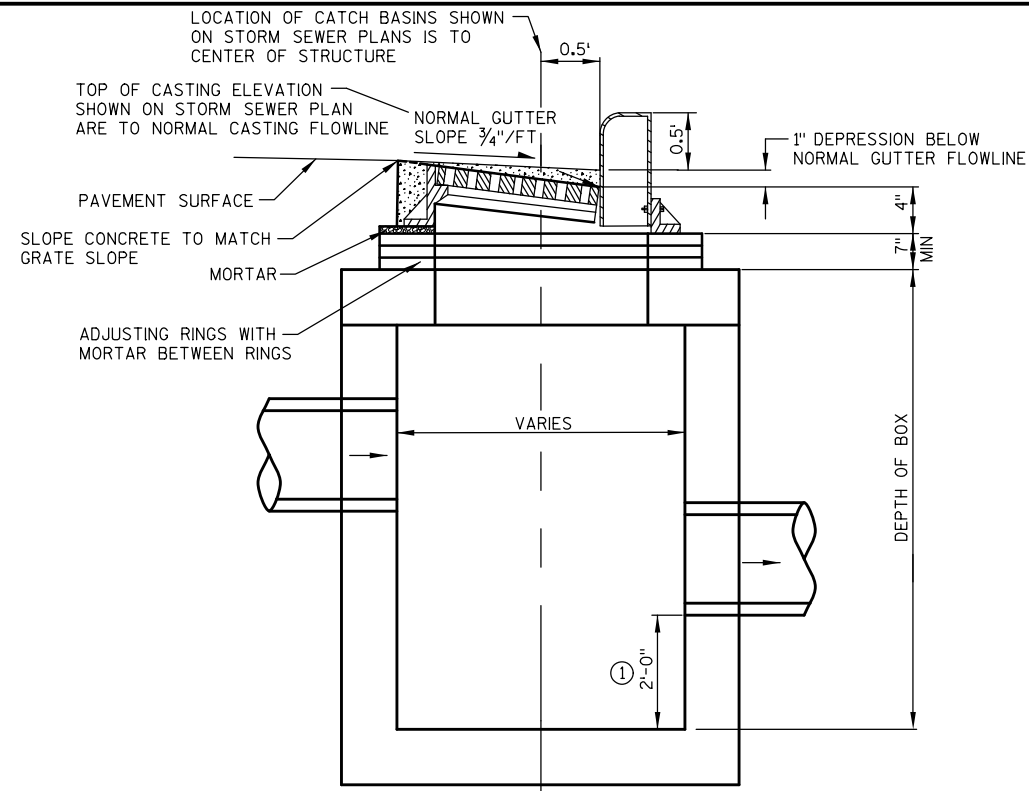

DETAIL OF CURB AND GUTTER AT CATCH BASINS

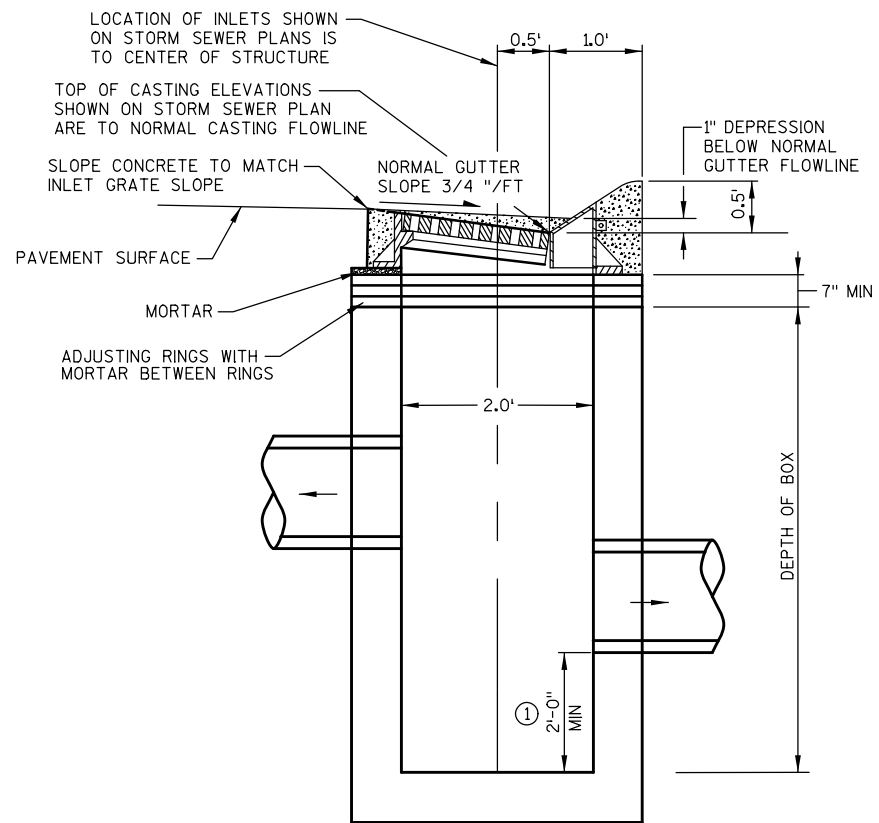

DETAIL OF CURB & GUTTER AT CATCH BASIN

① OMIT 2'-0" SUMP FOR INLETS

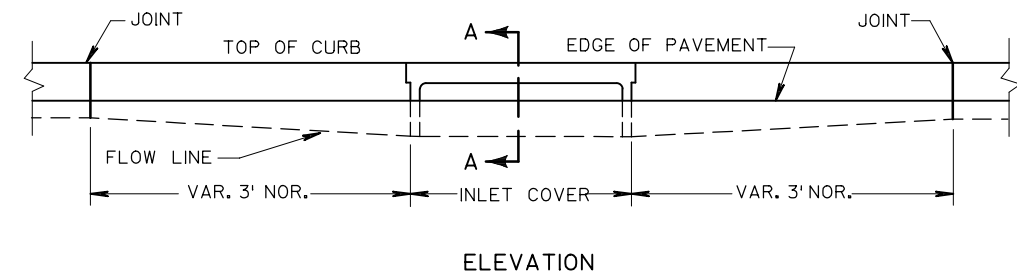

ELEVATION

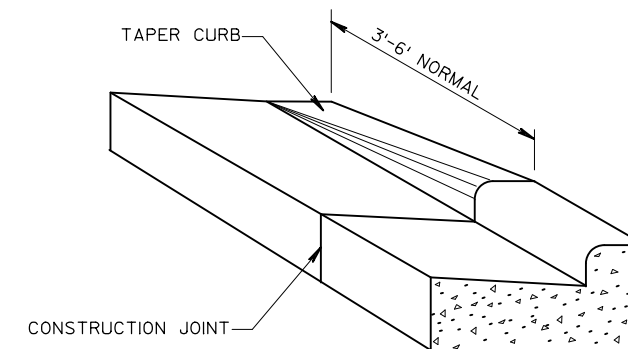
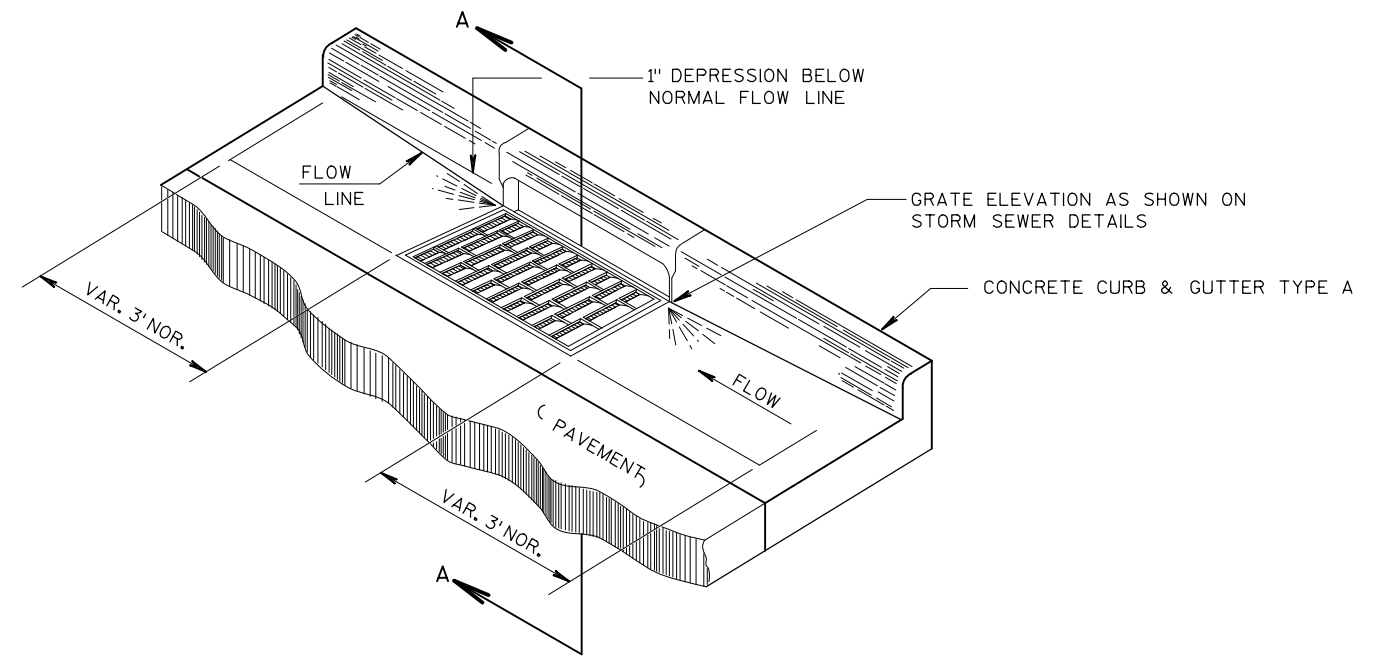

CURB & GUTTER TERMINI

NOTES:

- ① 6:1 SLOPES REQ'D WITHIN MAINLINE CLEAR ZONE IN FILL SECTIONS.

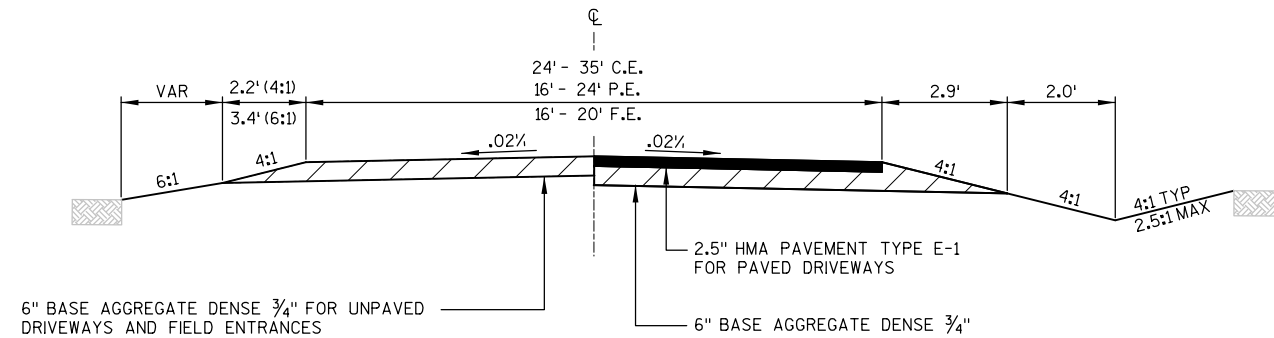

HALF SECTION IN FILL HALF SECTION IN CUT

TYPICAL SECTION FOR PRIVATE ENTRANCES

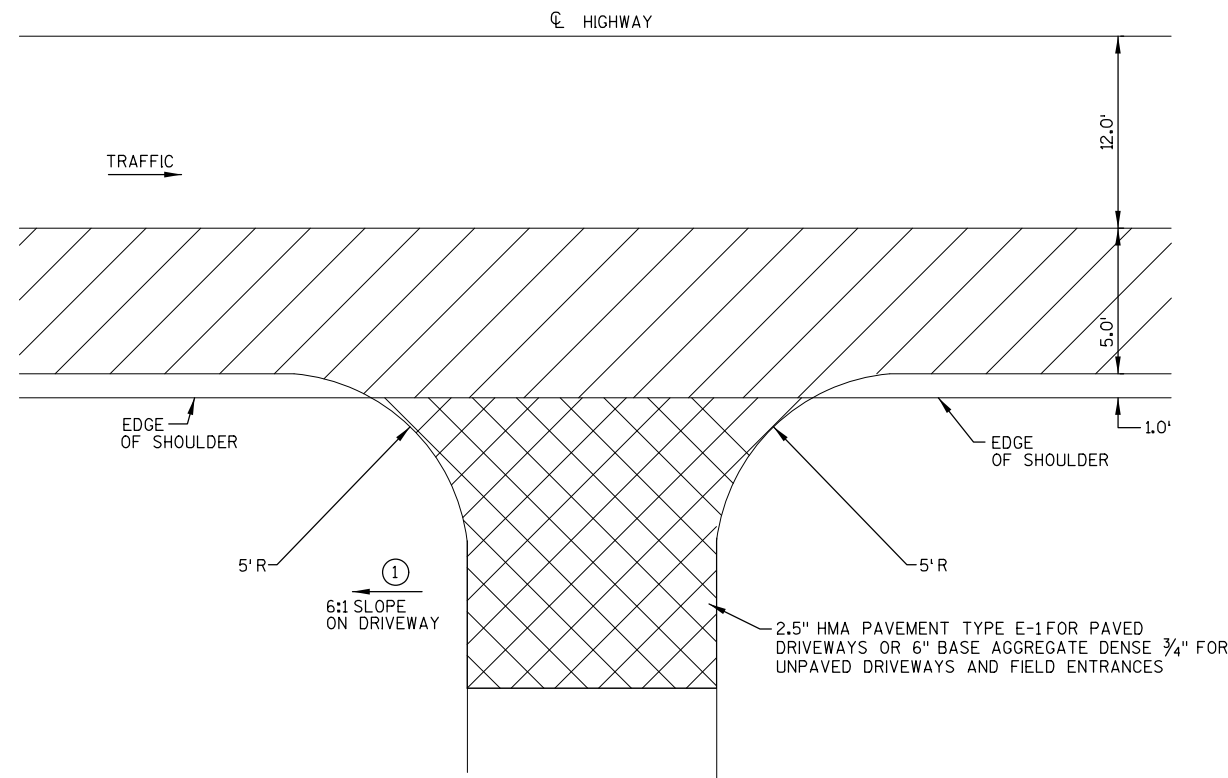

**PLAN VIEW
PRIVATE ENTRANCE DETAIL**

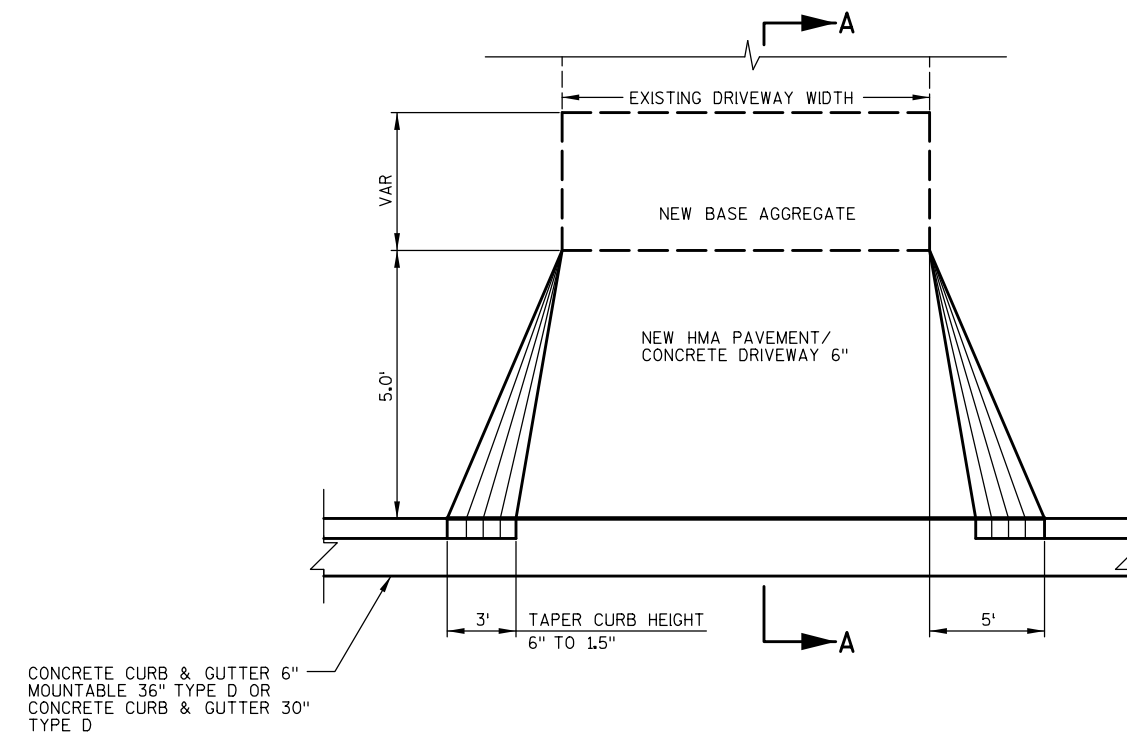

**PRIVATE ENTRANCE AT CURB AND GUTTER LOCATIONS
TYPE 1**

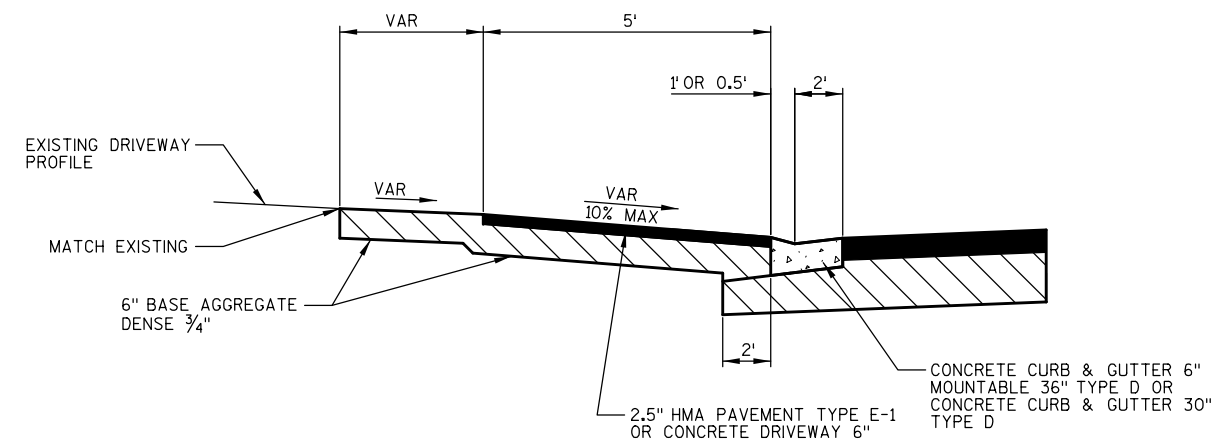

SECTION A-A

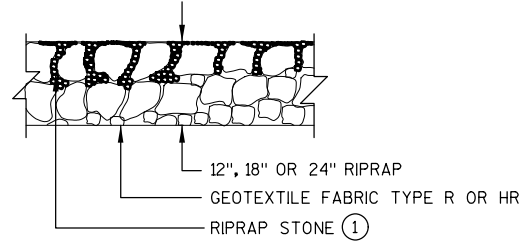

RIPRAP TREATMENT AT WATER WAYS AND DITCHES

STA 132+55 UNNAMED TRIBUTORY
 STA 217+54 WHITE CREEK
 STA 238+51 DUCK CREEK

NOTES:

① REFER TO MISCELLANEOUS QUANTITIES FOR LOCATIONS OF RIPRAP STONE.

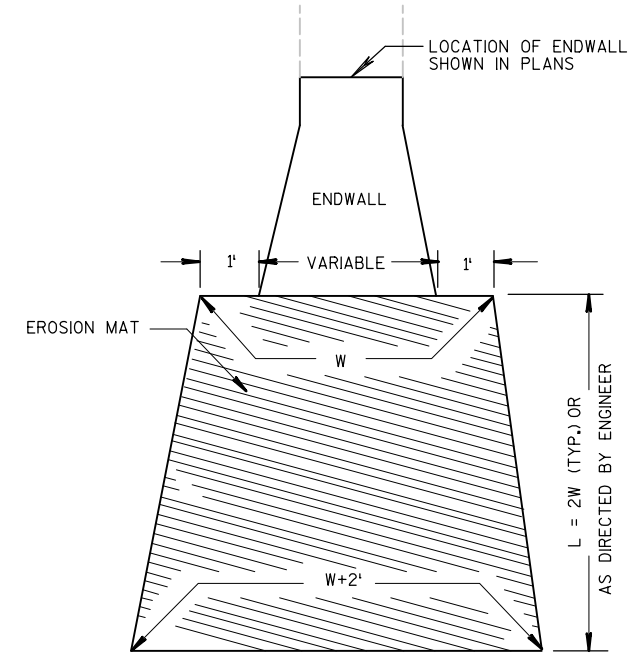

EROSION MAT TREATMENT AT CULVERTS

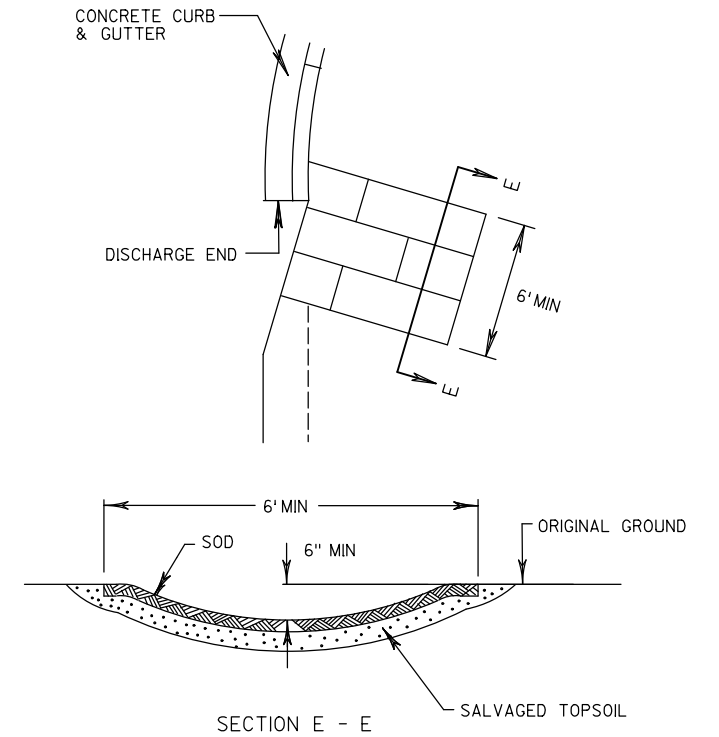

SOD FLUME DETAIL

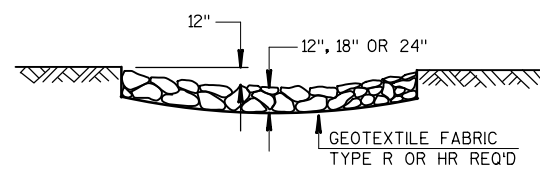
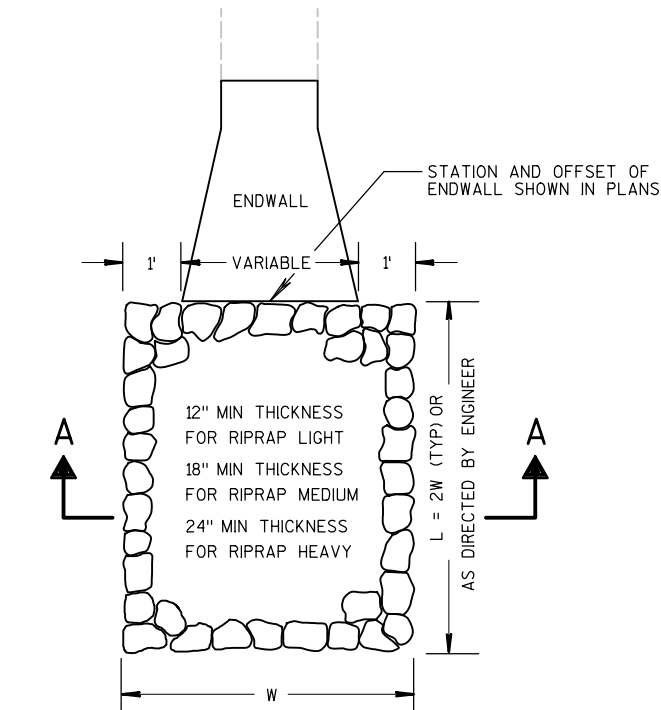

**SECTION A-A
 RIPRAP TREATMENT AT CULVERTS**

RUNOFF COEFFICIENT TABLE

	HYDROLOGIC SOIL GROUP											
	A			B			C			D		
	SLOPE RANGE (PERCENT)			SLOPE RANGE (PERCENT)			SLOPE RANGE (PERCENT)			SLOPE RANGE (PERCENT)		
LAND USE:	0-2	2-6	6 & OVER	0-2	2-6	6 & OVER	0-2	2-6	6 & OVER	0-2	2-6	6 & OVER
ROW CROPS	.08	.16	.22	.12	.20	.27	.15	.24	.33	.19	.28	.38
	.22	.30	.38	.26	.34	.44	.30	.37	.50	.34	.41	.56
MEDIAN STRIP-TURF	.19	.20	.24	.19	.22	.26	.20	.23	.30	.20	.25	.30
	.24	.26	.30	.25	.28	.33	.26	.30	.37	.27	.32	.40
SIDE SLOPE-TURF			.25			.27			.28			.30
			.32			.34			.36			.38
PAVEMENT:												
ASPHALT	.70 - .95											
CONCRETE	.80 - .95											
BRICK	.70 - .80											
DRIVES, WALKS	.75 - .85											
ROOFS	.75 - .95											
GRAVEL ROADS, SHOULDERS	.40 - .60											

TOTAL PROJECT AREA = 101.14 ACRES
 TOTAL AREA EXPECTED TO BE DISTURBED BY CONSTRUCTION ACTIVITIES = 113.87 ACRES

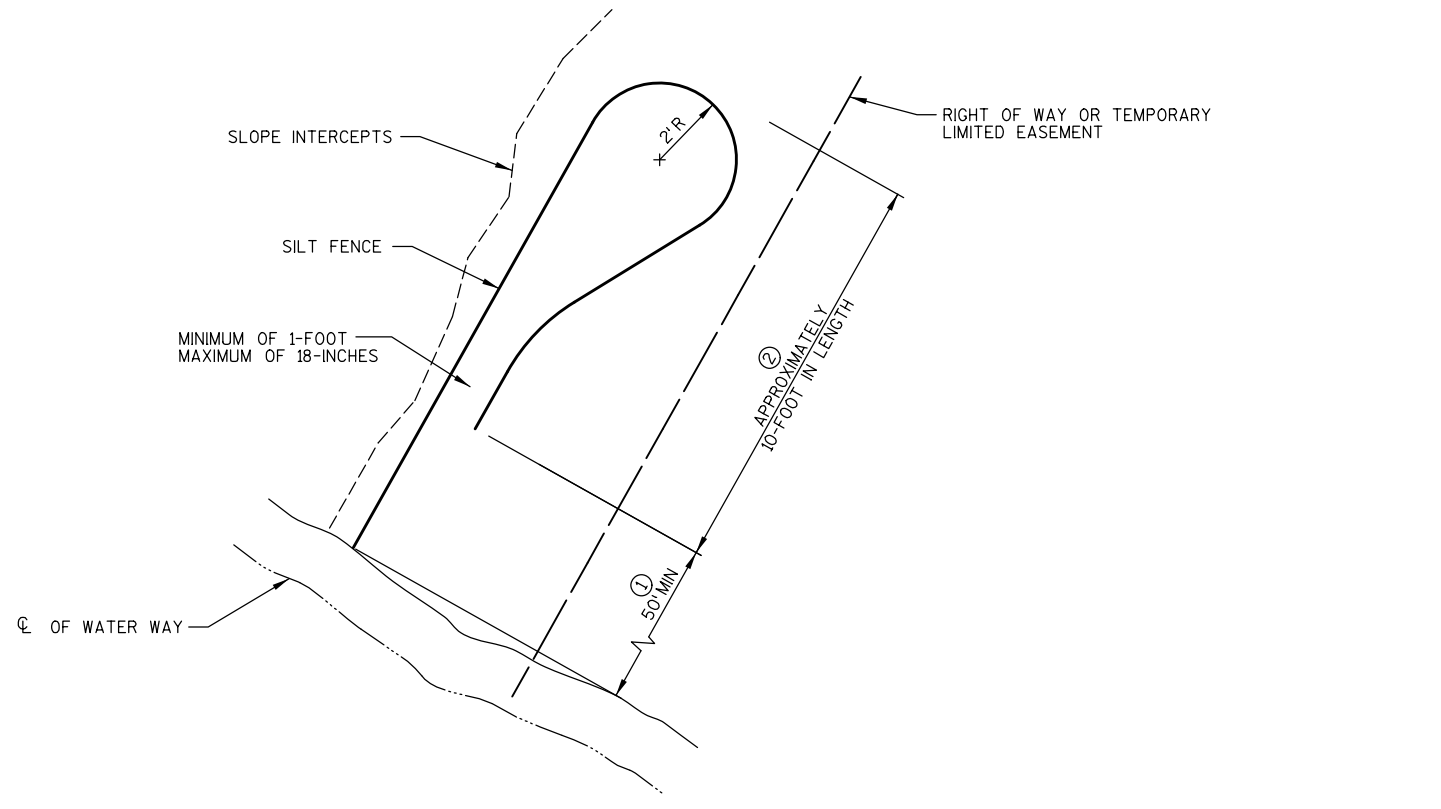

SILT FENCE TURN-AROUND DETAIL
END TREATMENT FOR WOOD TURTLE EXCLUSION

STA 132+55 UNNAMED TRIBUTARY
STA 217+54 WHITE CREEK
STA 238+21 DUCK CREEK

NOTES:

- ① CONSTRUCT TURN-AROUND END TREATMENT ALONG EACH SIDE OF WATER WAY. SEE EROSION CONTROL PLANS FOR LOCATIONS.
- ② PAYMENT FOR SILT FENCE TURN-AROUND WILL BE INCIDENTAL TO THE ITEM OF SILT FENCE.

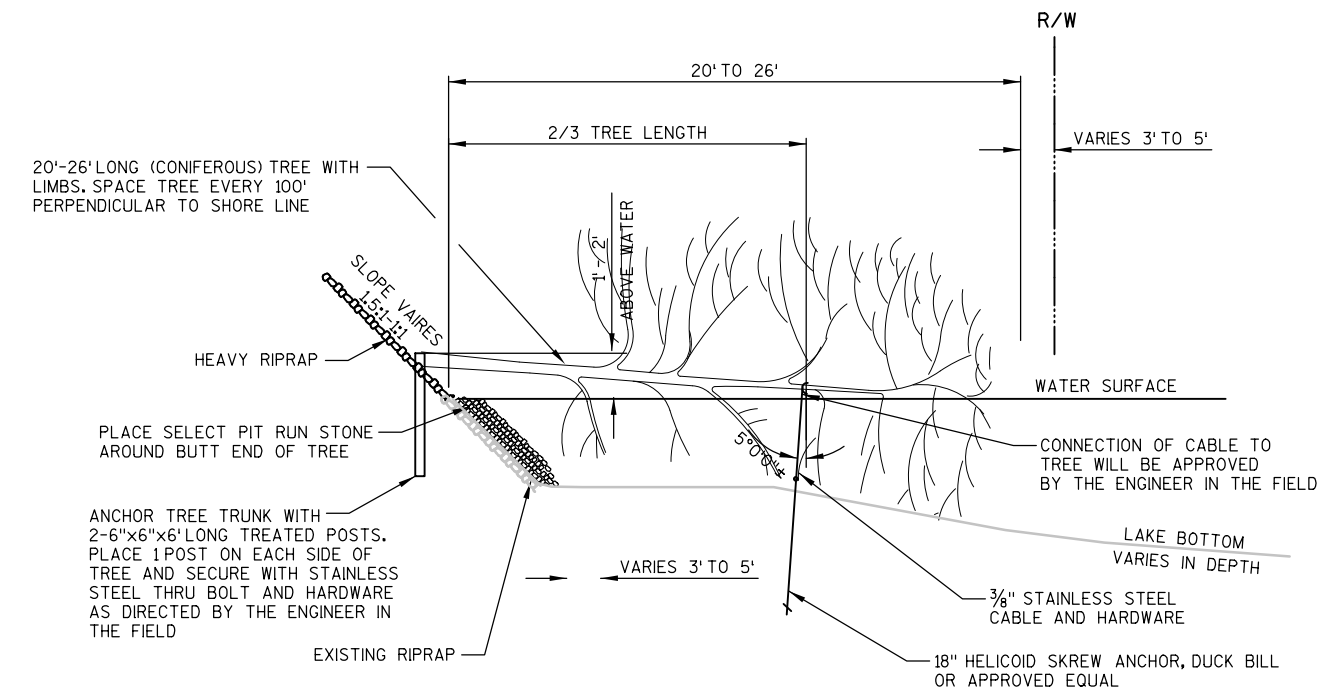

LOG FISH CRIB DETAIL

STA 631+00 LT
STA 632+00 LT
STA 633+00 LT
STA 636+00 LT
STA 637+00 LT

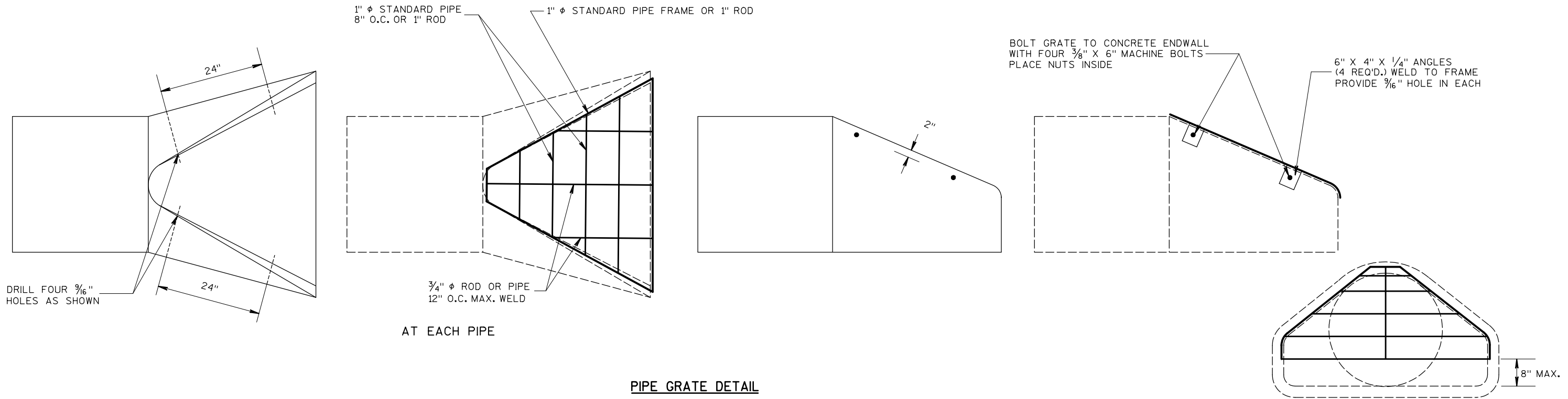

PIPE GRATE DETAIL

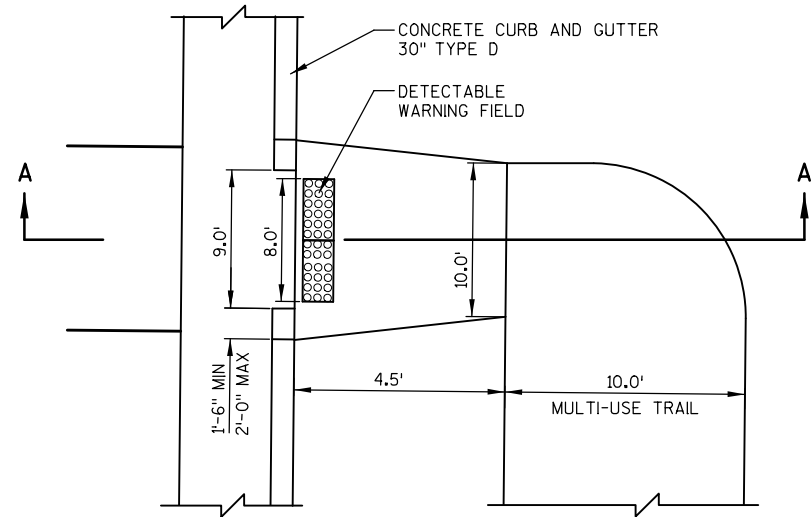

PLAN VIEW

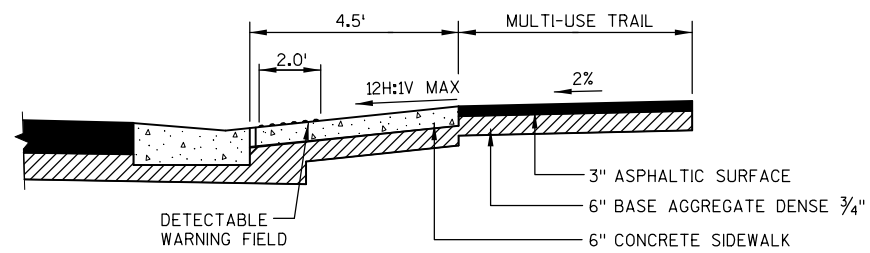

SECTION A-A

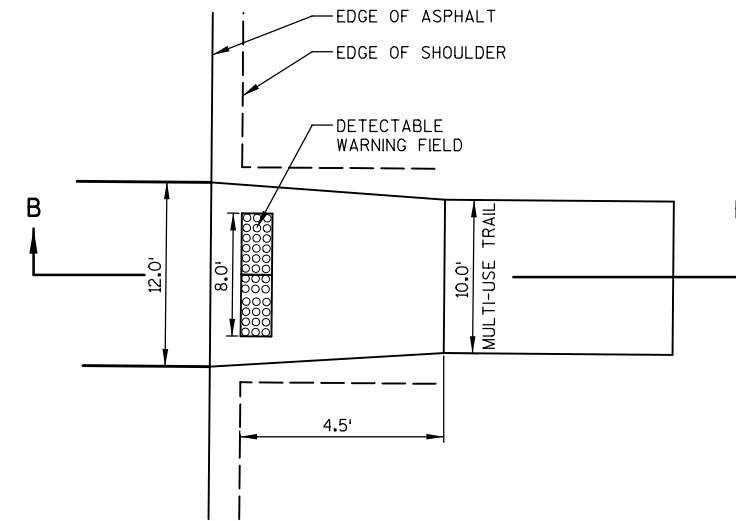

PLAN VIEW

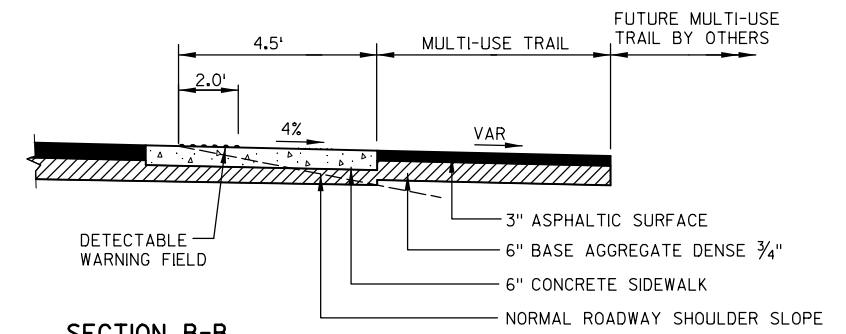

SECTION B-B

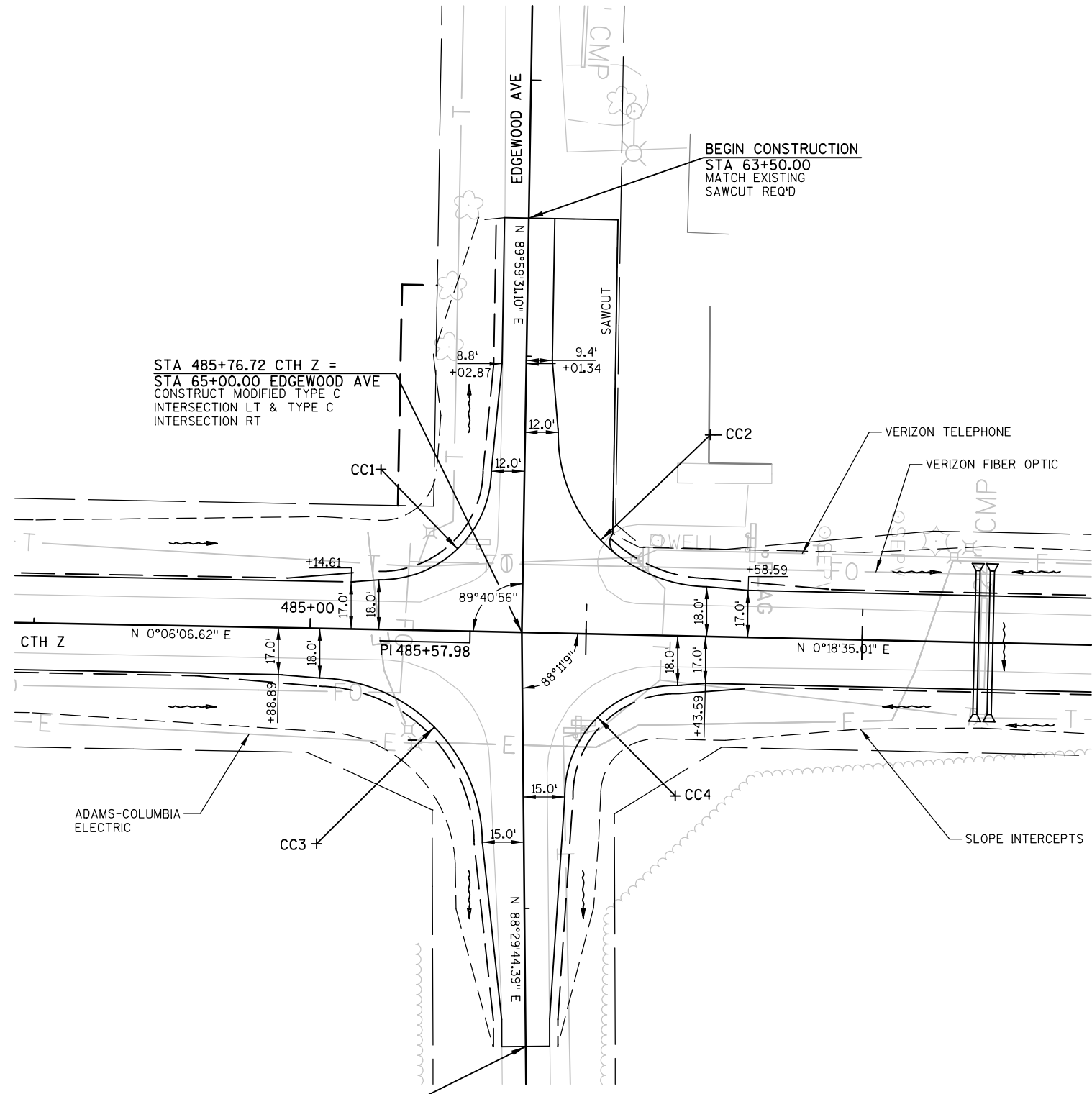

STA 485+76.72 CTH Z =
 STA 65+00.00 EDGEWOOD AVE
 CONSTRUCT MODIFIED TYPE C
 INTERSECTION LT & TYPE C
 INTERSECTION RT

BEGIN CONSTRUCTION
 STA 63+50.00
 MATCH EXISTING
 SAWCUT REQ'D

END CONSTRUCTION
 STA 66+50.00
 MATCH EXISTING
 SAWCUT REQ'D

RADIUS POINT TABLE				
POINT	STATION	OFFSET	RADIUS	COORDINATES
CC1	485+24.61 CTH Z	58.0'LT	40.0'R	Y = 185790.499
	64+41.84 EDGEWOOD AVE	52.0'RT		X = 499210.750
CC2	486+43.32 CTH Z	73.0'LT	55.0'R	Y = 185909.497
	64+27.37 EDGEWOOD AVE	67.0'LT		X = 499196.271
CC3	485+03.88 CTH Z	78.0'RT	60.0'R	Y = 185769.527
	65+75.86 EDGEWOOD AVE	75.0'RT		X = 499346.715
CC4	486+33.59 CTH Z	58.0'RT	40.0'R	Y = 185899.060
	65+59.78 EDGEWOOD AVE	55.0'LT		X = 499327.221

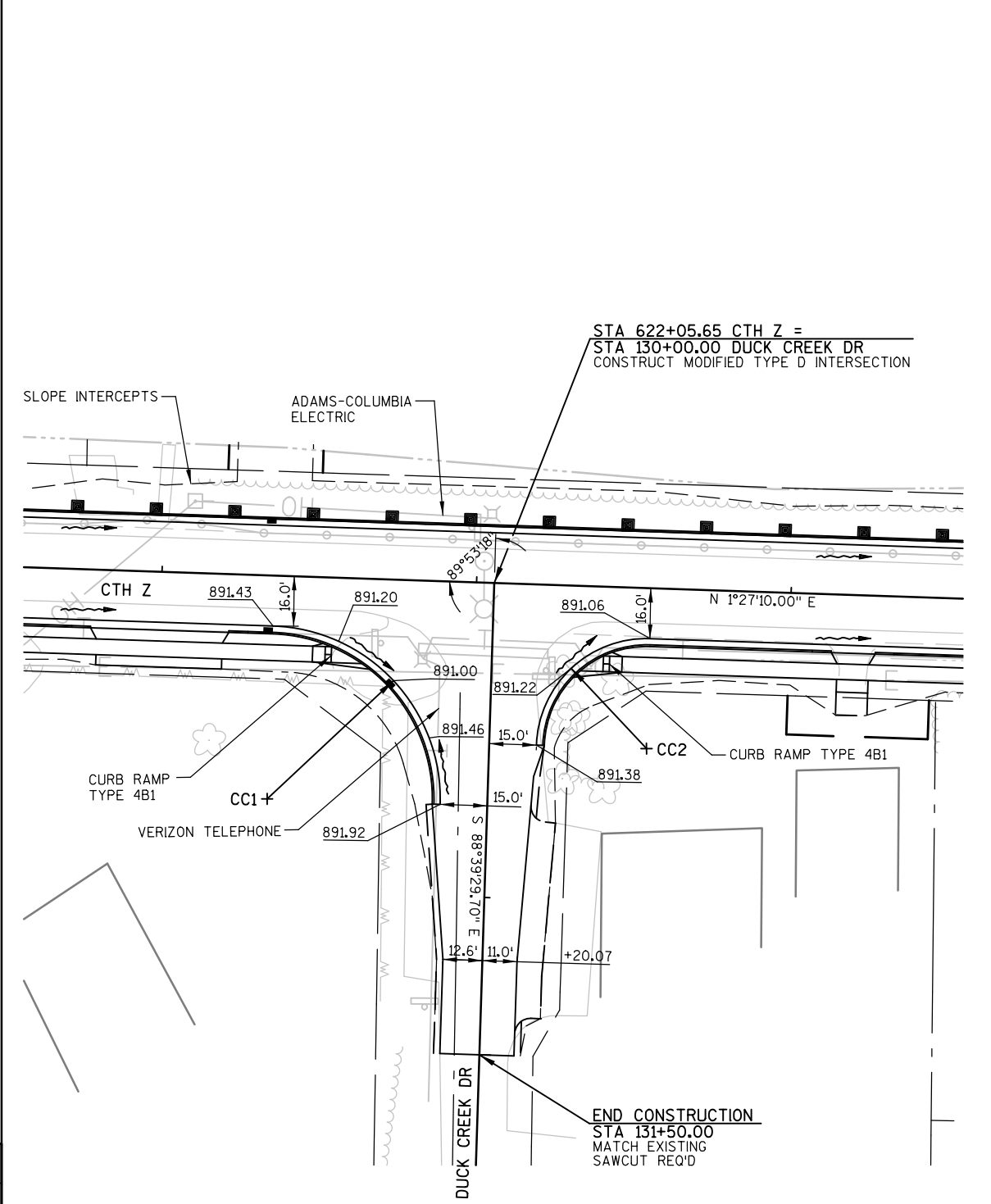
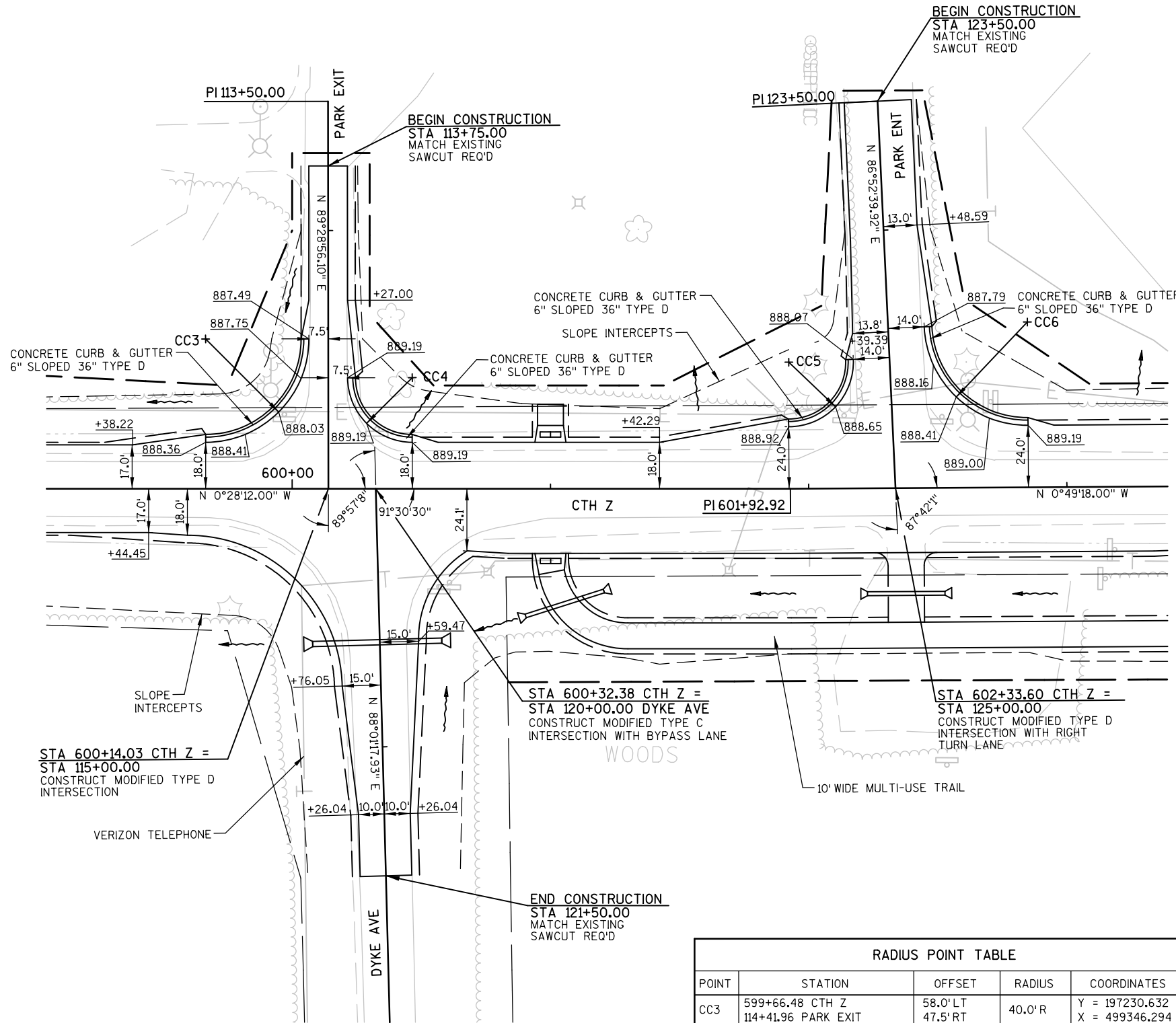

RADIUS POINT TABLE

POINT	STATION	OFFSET	RADIUS	COORDINATES
CC3	599+66.48 CTH Z	58.0' LT	40.0' R	Y = 197230.632
	114+41.96 PARK EXIT	47.5' RT		X = 499346.294
CC4	600+46.49 CTH Z	43.0' LT	25.0' R	Y = 197310.765
	114+57.02 PARK EXIT	32.5' LT		X = 499360.637
CC5	601+92.30 CTH Z	49.0' LT	25.0' R	Y = 197456.520
	124+49.39 PARK ENT	39.0' RT		X = 499353.441
CC6	602+85.07 CTH Z	64.0' LT	40.0' R	Y = 197548.767
	124+38.12 PARK ENT	54.0' LT		X = 499337.119

RADIUS POINT TABLE

POINT	STATION	OFFSET	RADIUS	COORDINATES
CC1	621+35.80 CTH Z	71.0' RT	55.0' R	Y=199398.440
	130+70.87 DUCK CREEK DR	70.0' RT		X=499465.994
CC2	622+55.76 CTH Z	51.0' RT	35.0' R	Y=199518.870
	130+51.10 DUCK CREEK DR	50.0' LT		X=499449.033

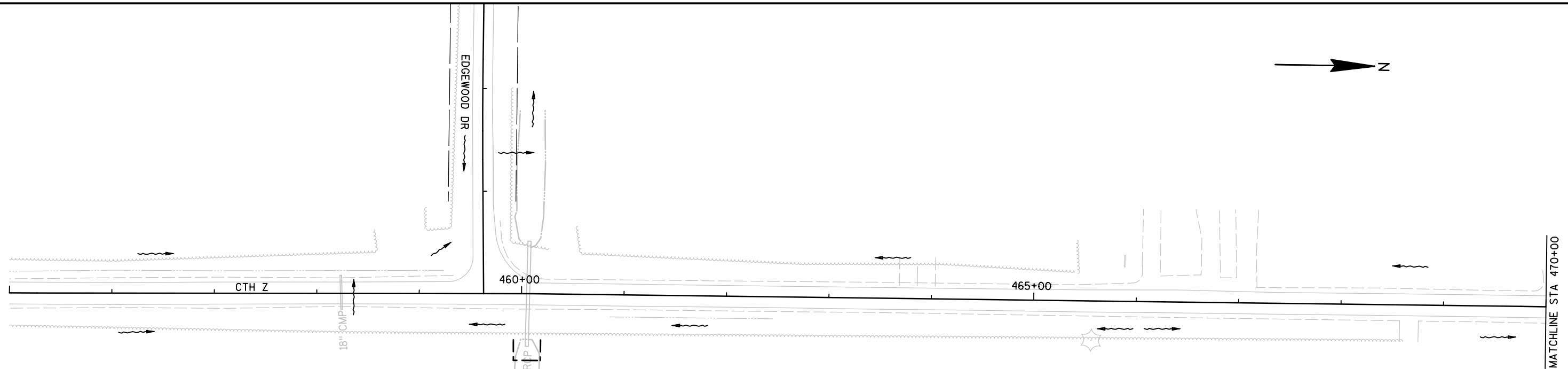

LEGEND

- SOD DITCH CHECKS
- EROSION MAT URBAN CLASS I TYPE A
- EROSION MAT URBAN CLASS I TYPE B
- EROSION MAT CLASS I TYPE B
- EROSION MAT CLASS II TYPE B
- RIPRAP LIGHT WITH GEOTEXTILE FABRIC TYPE R
- RIPRAP MEDIUM WITH GEOTEXTILE FABRIC TYPE R
- RIPRAP HEAVY WITH GEOTEXTILE FABRIC TYPE HR
- SILT FENCE
- SILT SCREEN
- TURBIDITY BARRIERS
- DRAINAGE ARROW
- TEMPORARY DITCH CHECKS
- SILT FENCE DURING EBS
- CULVERT PIPE DITCH CHECK

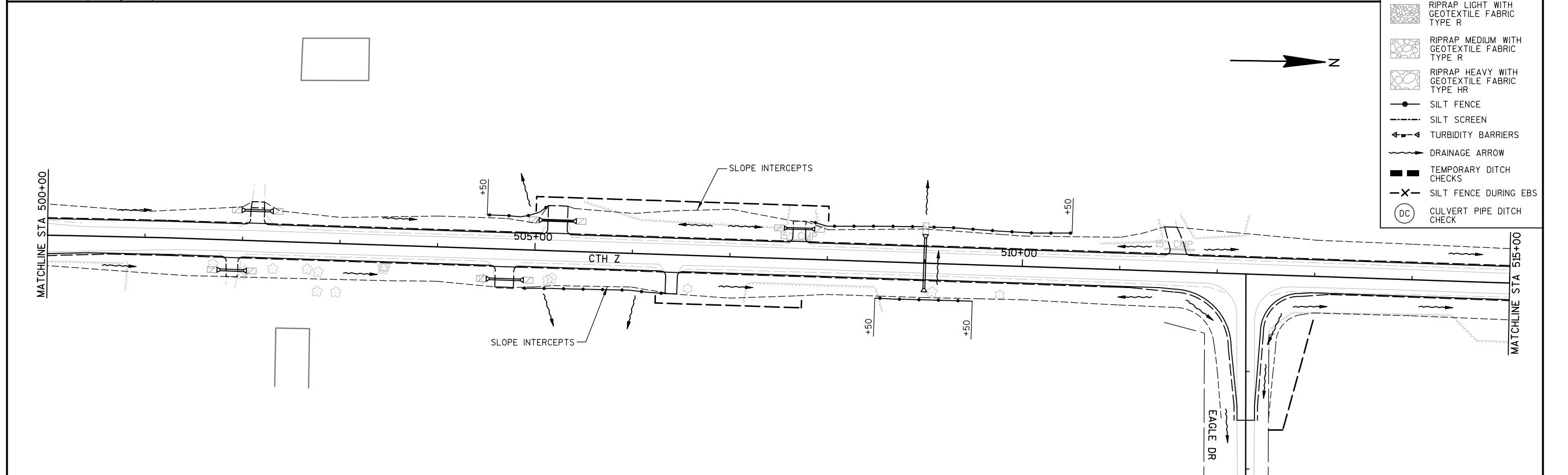
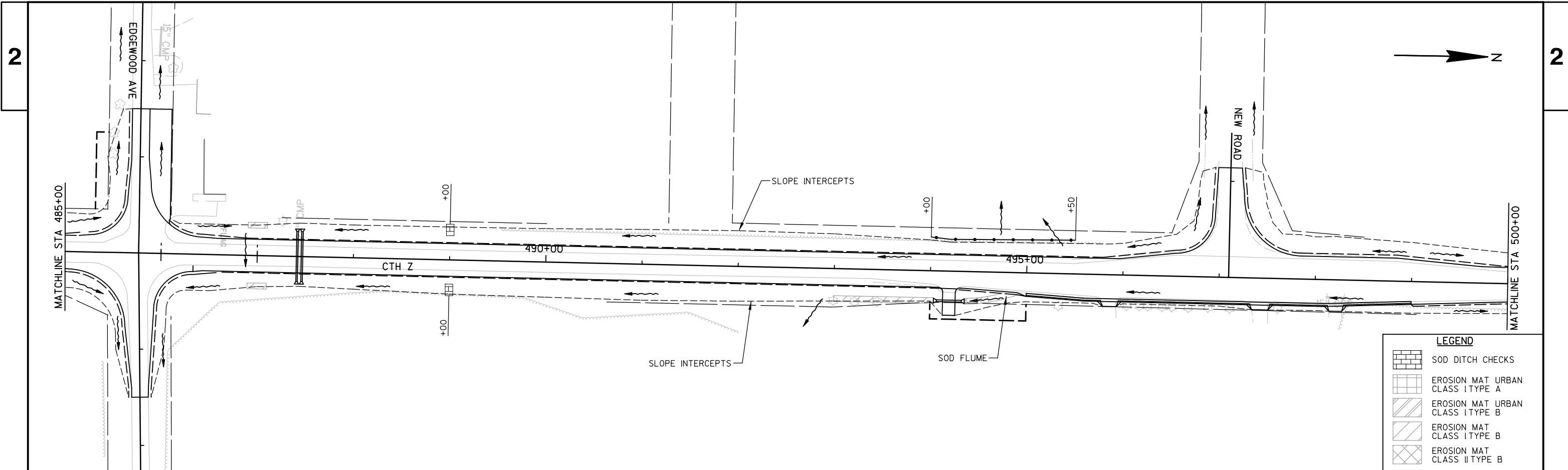

LEGEND

	SOD DITCH CHECKS
	EROSION MAT URBAN CLASS I TYPE A
	EROSION MAT URBAN CLASS I TYPE B
	EROSION MAT CLASS I TYPE B
	EROSION MAT CLASS II TYPE B
	RIPRAP LIGHT WITH GEOTEXTILE FABRIC TYPE R
	RIPRAP MEDIUM WITH GEOTEXTILE FABRIC TYPE R
	RIPRAP HEAVY WITH GEOTEXTILE FABRIC TYPE HR
	SILT FENCE
	SILT SCREEN
	TURBIDITY BARRIERS
	DRAINAGE ARROW
	TEMPORARY DITCH CHECKS
	SILT FENCE DURING EBS
	CULVERT PIPE DITCH CHECK

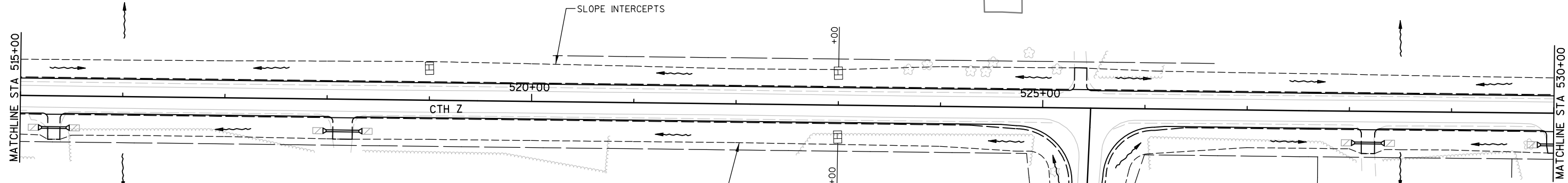

LEGEND

	SOD DITCH CHECKS
	EROSION MAT URBAN CLASS I TYPE A
	EROSION MAT URBAN CLASS I TYPE B
	EROSION MAT CLASS I TYPE B
	EROSION MAT CLASS II TYPE B
	RIPRAP LIGHT WITH GEOTEXTILE FABRIC TYPE R
	RIPRAP MEDIUM WITH GEOTEXTILE FABRIC TYPE R
	RIPRAP HEAVY WITH GEOTEXTILE FABRIC TYPE HR
	SILT FENCE
	SILT SCREEN
	TURBIDITY BARRIERS
	DRAINAGE ARROW
	TEMPORARY DITCH CHECKS
	SILT FENCE DURING EBS
	CULVERT PIPE DITCH CHECK

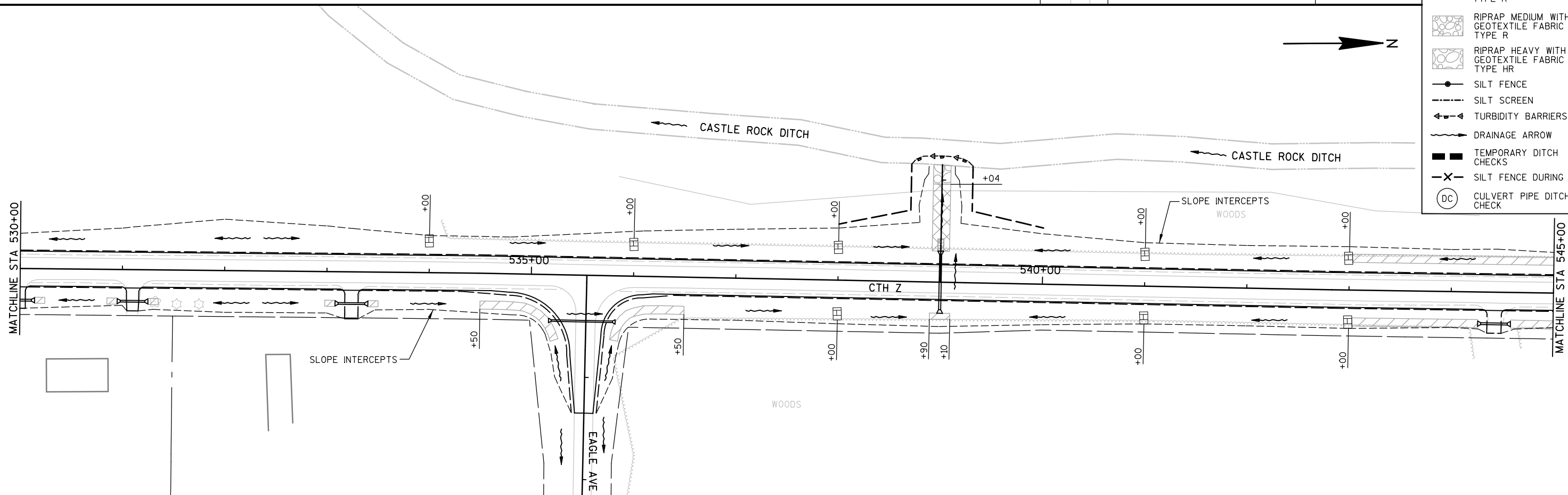

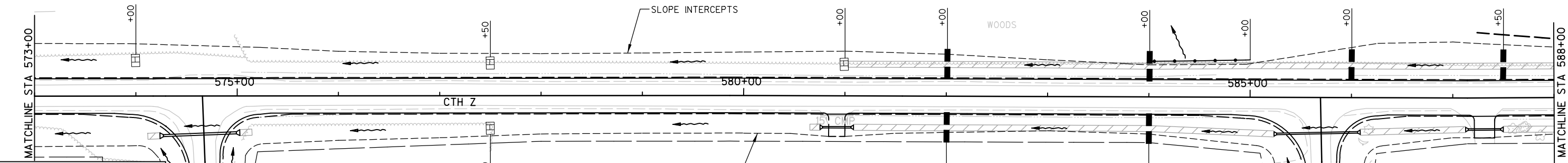
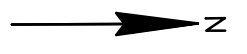

- LEGEND**
- SOD DITCH CHECKS
 - EROSION MAT URBAN CLASS I TYPE A
 - EROSION MAT URBAN CLASS I TYPE B
 - EROSION MAT CLASS I TYPE B
 - EROSION MAT CLASS II TYPE B
 - RIPRAP LIGHT WITH GEOTEXTILE FABRIC TYPE R
 - RIPRAP MEDIUM WITH GEOTEXTILE FABRIC TYPE R
 - RIPRAP HEAVY WITH GEOTEXTILE FABRIC TYPE HR
 - SILT FENCE
 - SILT SCREEN
 - TURBIDITY BARRIERS
 - DRAINAGE ARROW
 - TEMPORARY DITCH CHECKS
 - SILT FENCE DURING EBS
 - CULVERT PIPE DITCH CHECK

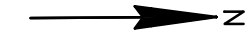
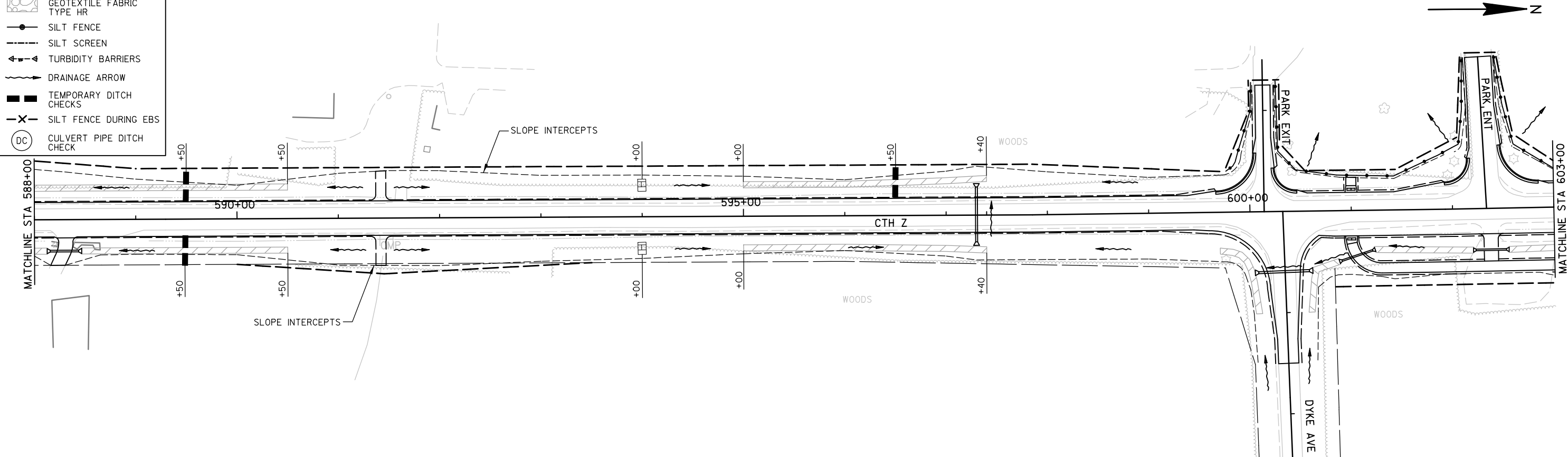

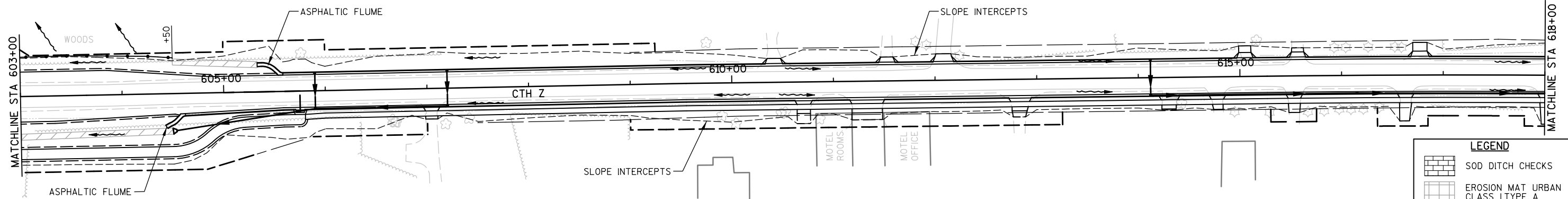

LEGEND

[Symbol]	SOD DITCH CHECKS
[Symbol]	EROSION MAT URBAN CLASS I TYPE A
[Symbol]	EROSION MAT URBAN CLASS I TYPE B
[Symbol]	EROSION MAT CLASS I TYPE B
[Symbol]	EROSION MAT CLASS II TYPE B
[Symbol]	RIPRAP LIGHT WITH GEOTEXTILE FABRIC TYPE R
[Symbol]	RIPRAP MEDIUM WITH GEOTEXTILE FABRIC TYPE R
[Symbol]	RIPRAP HEAVY WITH GEOTEXTILE FABRIC TYPE HR
[Symbol]	SILT FENCE
[Symbol]	SILT SCREEN
[Symbol]	TURBIDITY BARRIERS
[Symbol]	DRAINAGE ARROW
[Symbol]	TEMPORARY DITCH CHECKS
[Symbol]	SILT FENCE DURING EBS
[Symbol]	CULVERT PIPE DITCH CHECK

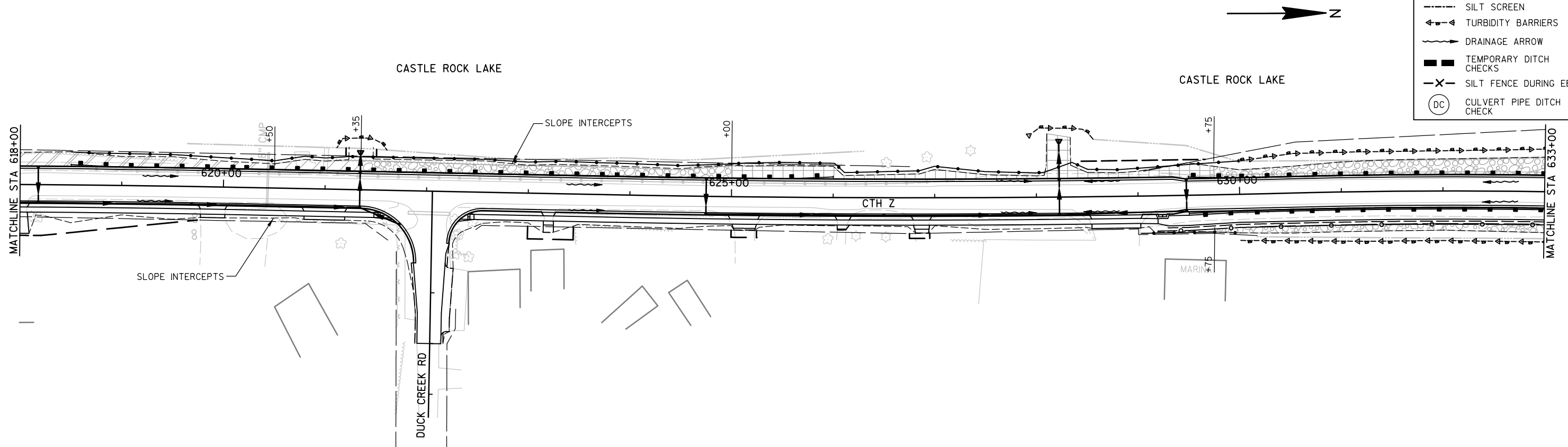



CASTLE ROCK LAKE

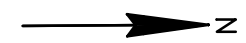
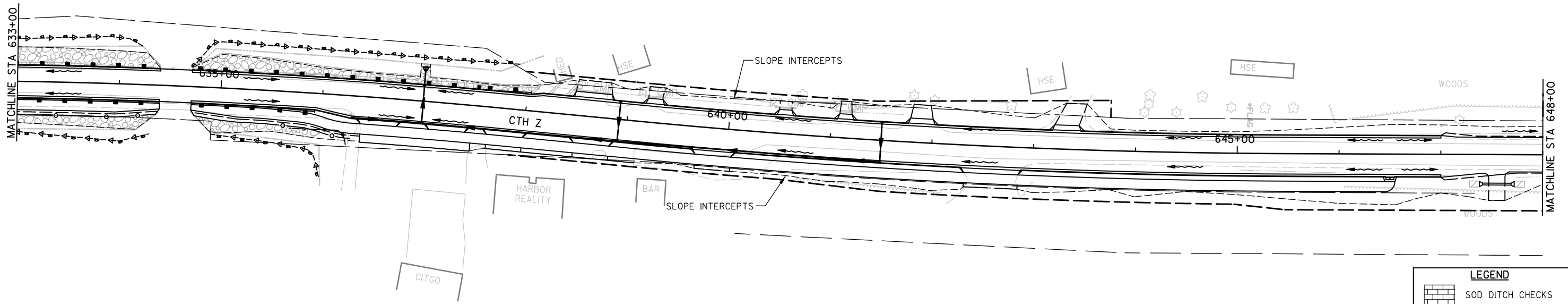

LEGEND

	SOD DITCH CHECKS
	EROSION MAT URBAN CLASS I TYPE A
	EROSION MAT URBAN CLASS I TYPE B
	EROSION MAT CLASS I TYPE B
	EROSION MAT CLASS II TYPE B
	RIPRAP LIGHT WITH GEOTEXTILE FABRIC TYPE R
	RIPRAP MEDIUM WITH GEOTEXTILE FABRIC TYPE R
	RIPRAP HEAVY WITH GEOTEXTILE FABRIC TYPE HR
	SILT FENCE
	SILT SCREEN
	TURBIDITY BARRIERS
	DRAINAGE ARROW
	TEMPORARY DITCH CHECKS
	SILT FENCE DURING EBS
	CULVERT PIPE DITCH CHECK

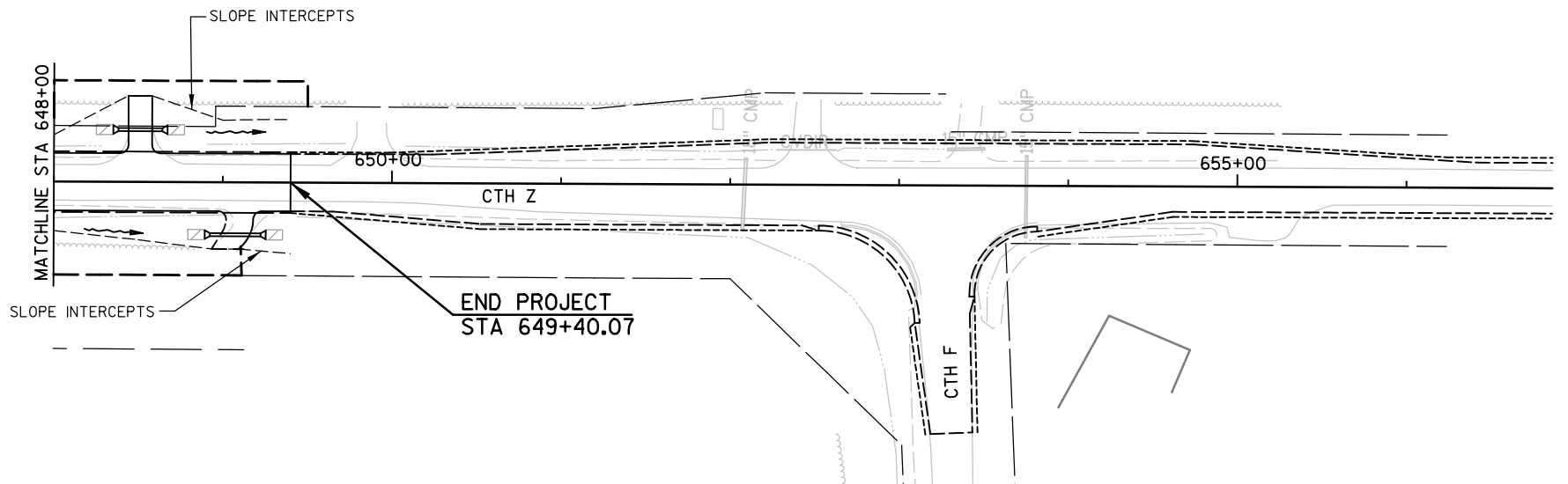

BENCHMARK TABLE

NO	STATION	DESCRIPTION	ELEV
35	609+71.53, 24.2' LT	3/8" SPK IN PP# 2 W SIDE OF CTH Z 150'± SW OF NIAWATHA MOTEL	895.45

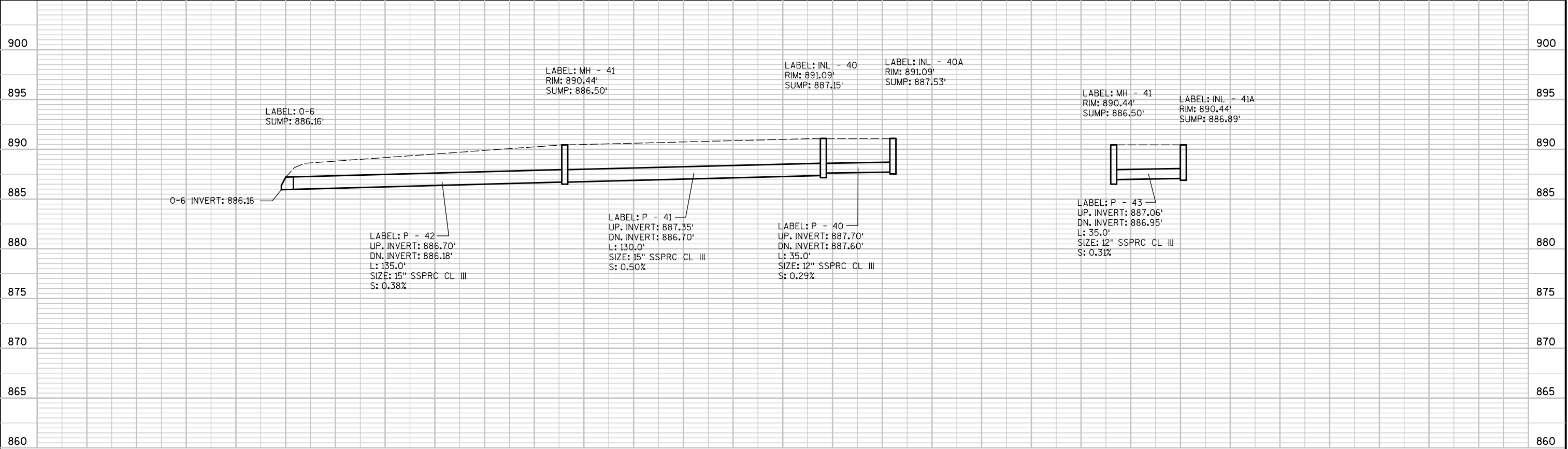
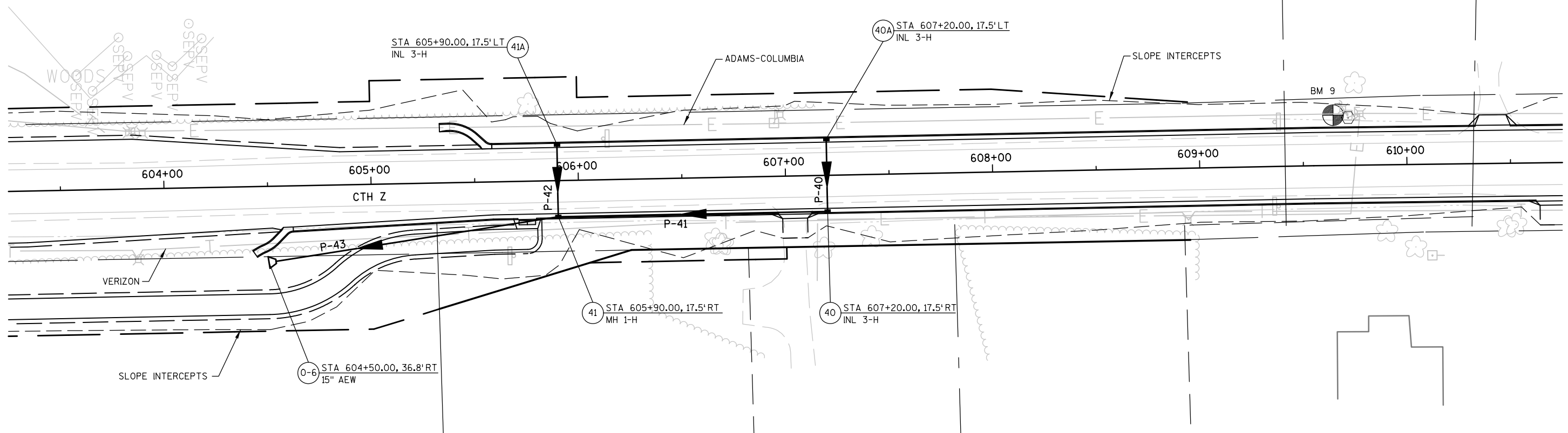
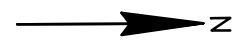

BENCHMARK TABLE

NO	STATION	DESCRIPTION	ELEV
35	609+71.53, 24.2' LT	3/8" SPK IN PP# 2 W SIDE OF CTH Z 150'± SW OF NIAWATHA MOTEL	895.45

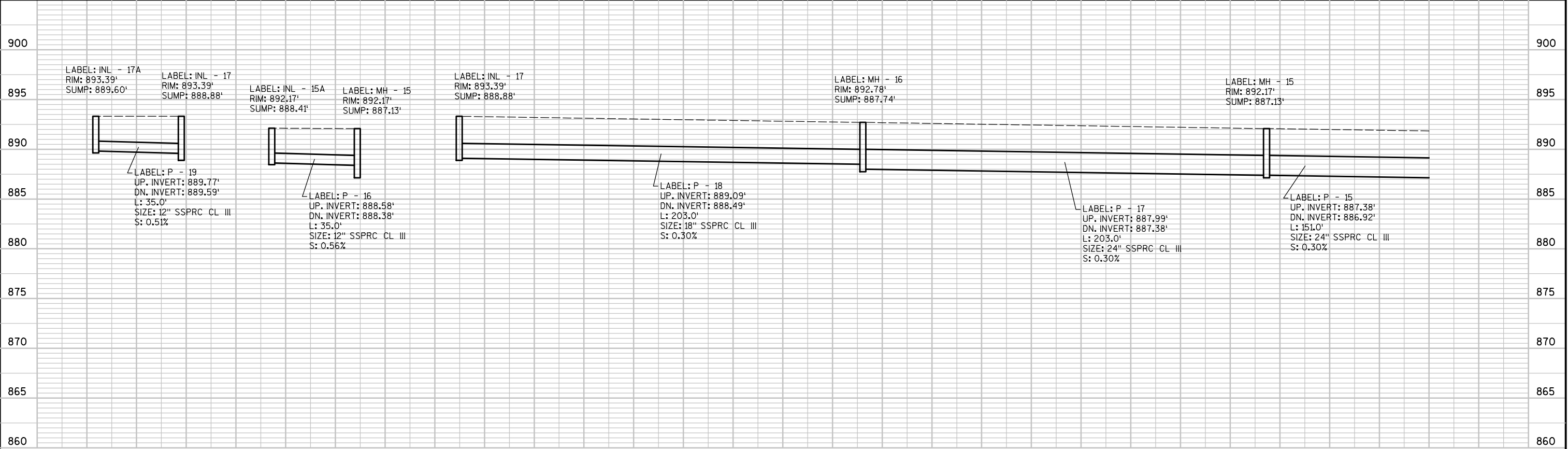
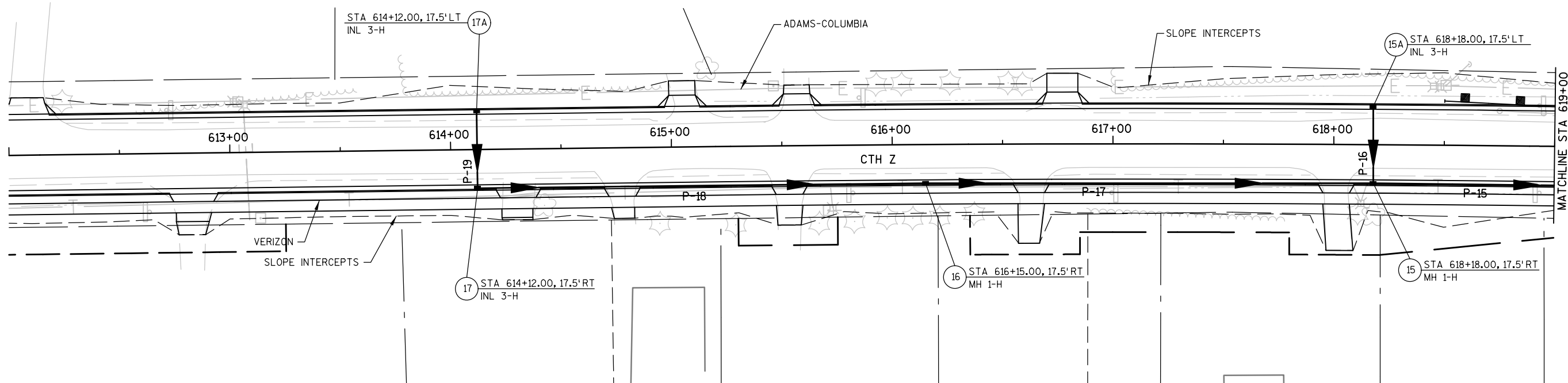
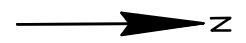

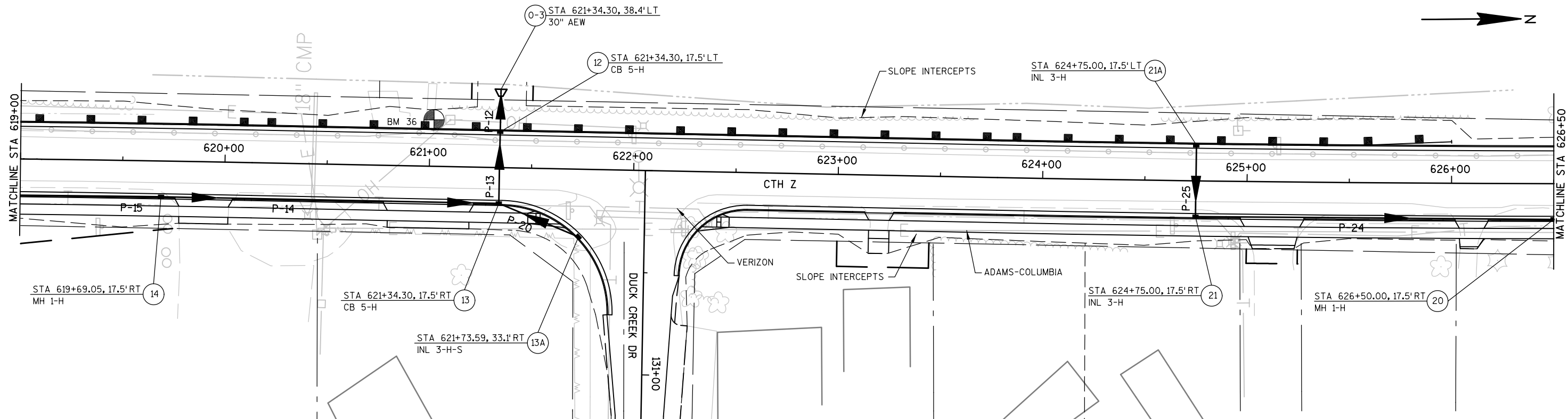

BENCHMARK TABLE

NO	STATION	DESCRIPTION	ELEV
36	621+09.81, 22.8' LT	3/8" SPK IN PP W SIDE CTH Z & 100'± S OF DUCK CREEK DRIVE	889.53

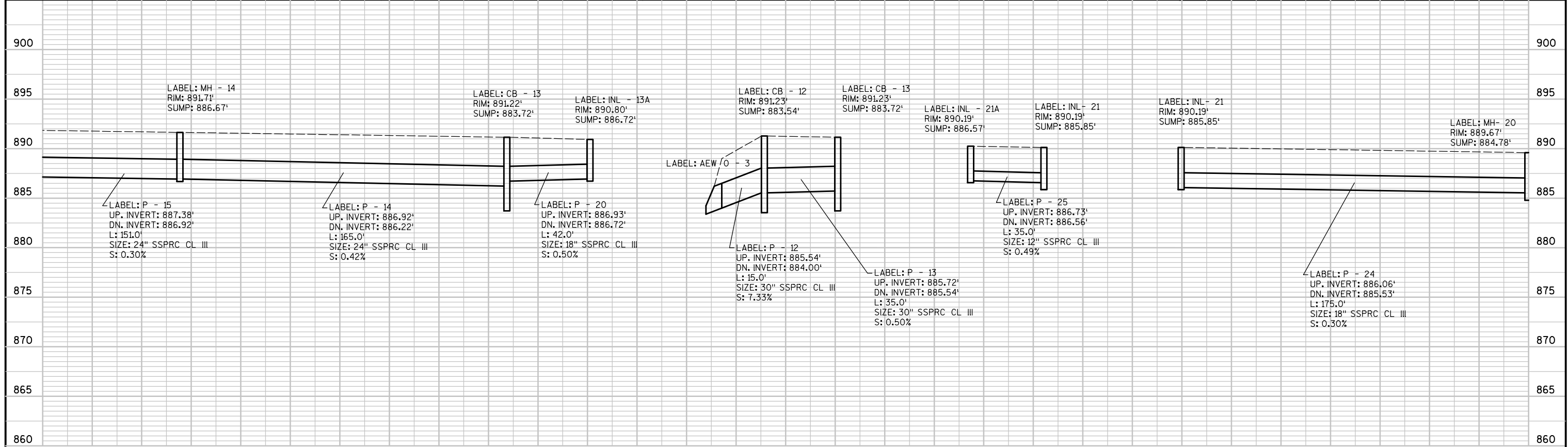

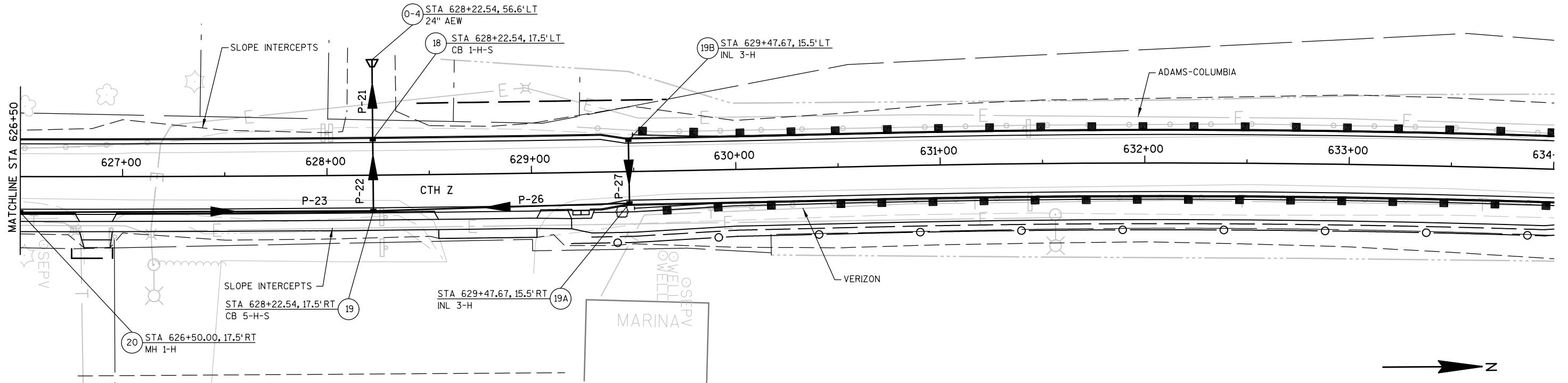

BENCHMARK TABLE

NO	STATION	DESCRIPTION	ELEV
36	621+09.81, 22.8' LT	3/8" SPK IN PP W SIDE CTH Z & 100'+ S OF DUCK CREEK DRIVE	889.53

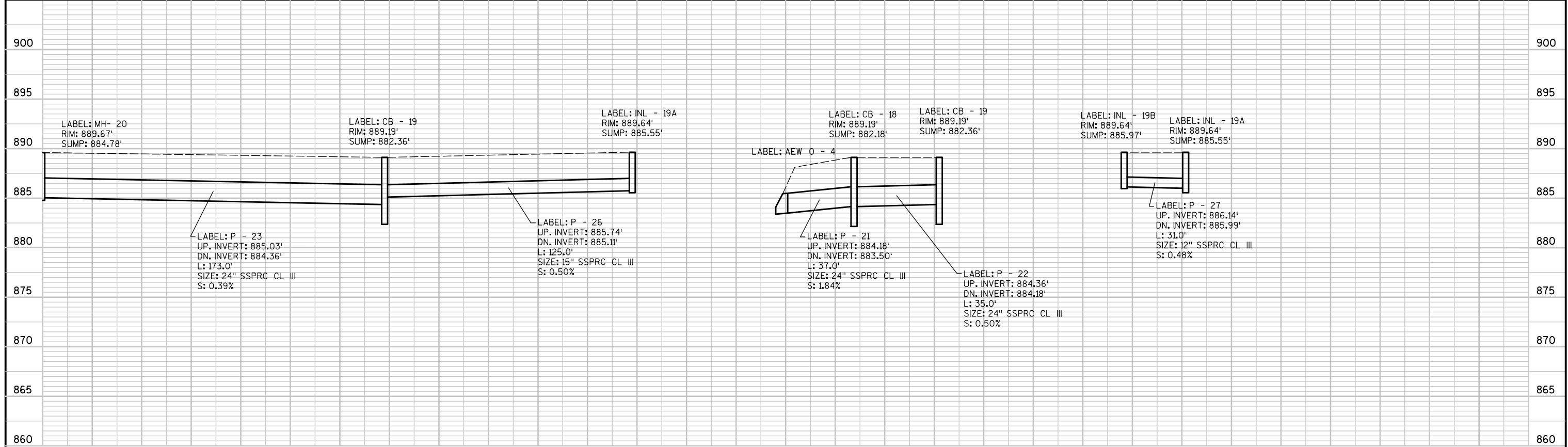

BENCHMARK TABLE

NO	STATION	DESCRIPTION	ELEV
38	645+60.89, 32.5' LT	3/8" SPK IN PP W SIDE CTH Z 200'+ N OF GOODIN RD	901.57

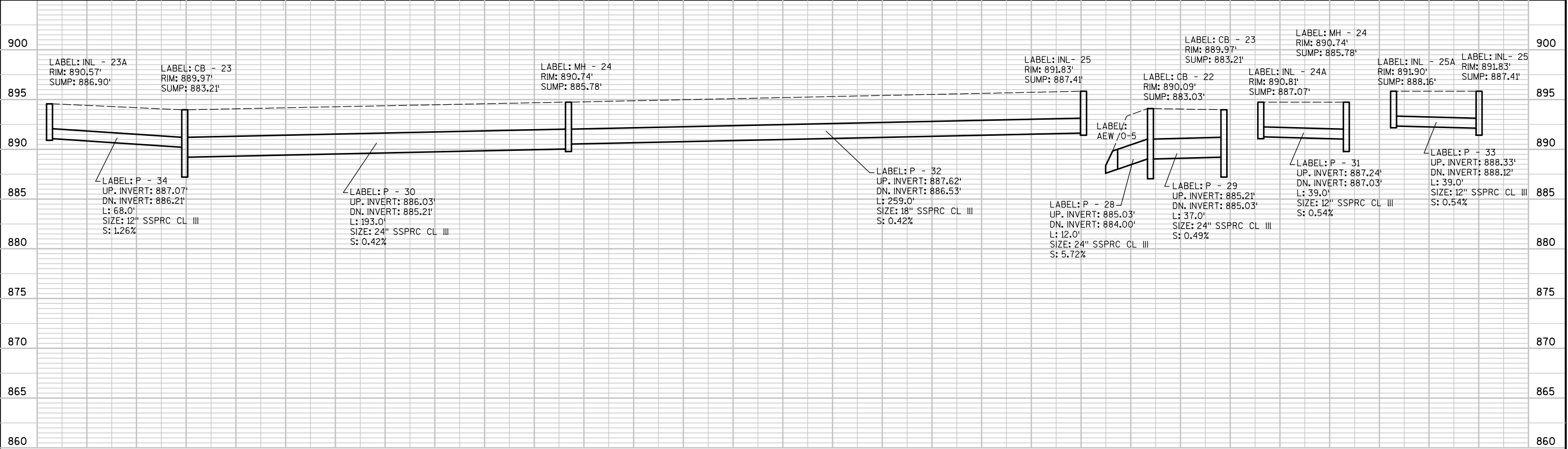
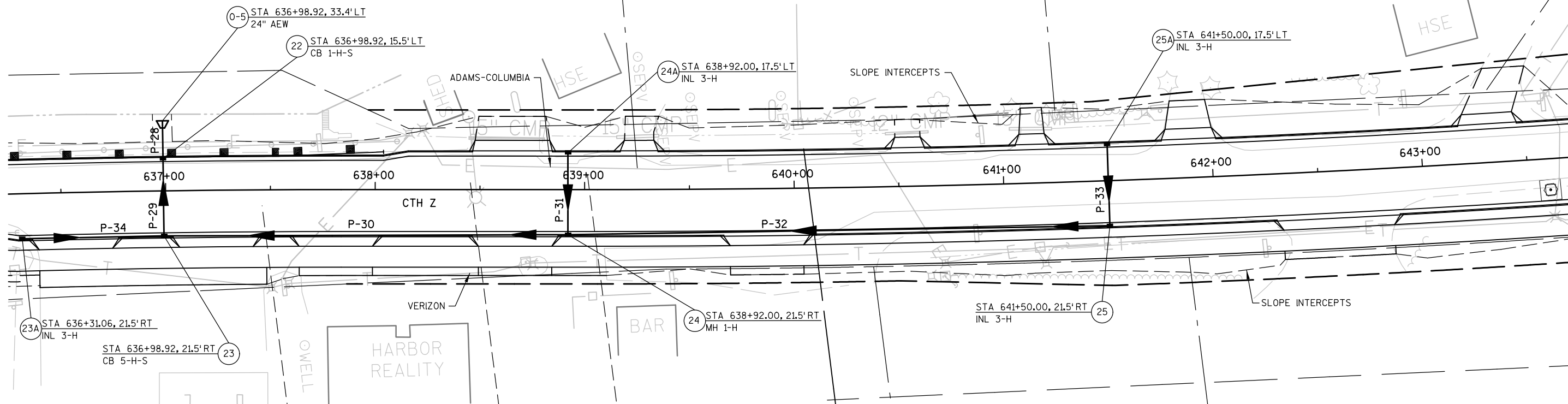

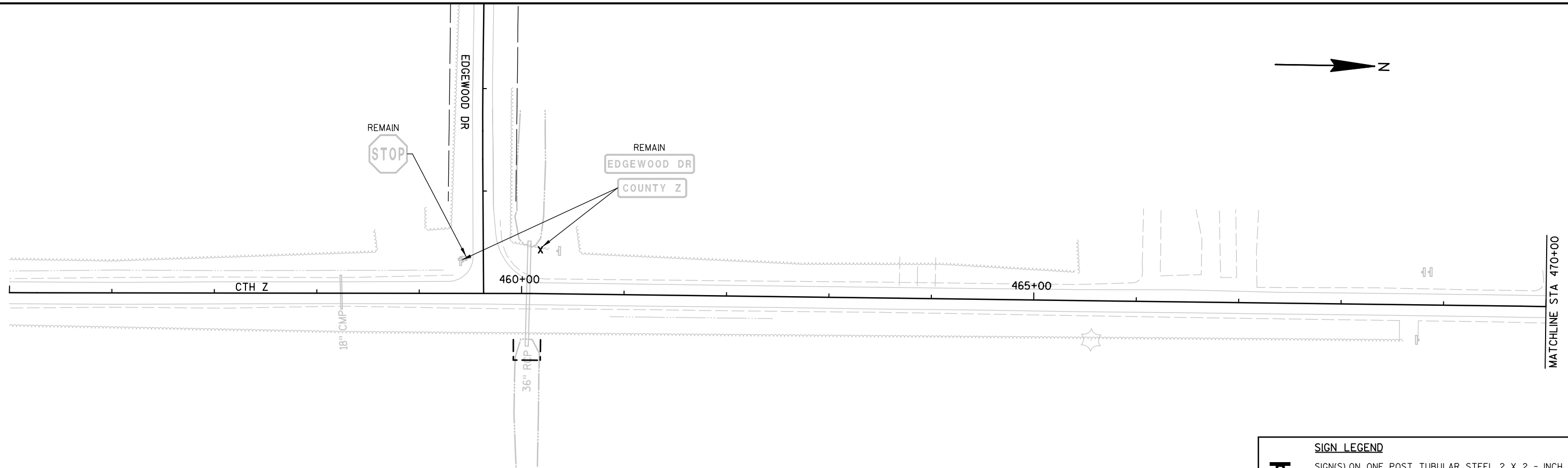

SIGN LEGEND	
	SIGN(S) ON ONE POST TUBULAR STEEL 2 X 2 - INCH
	SIGN(S) ON ONE WOOD POST
	SIGN(S) ON TWO WOOD POST
	SIGN GROUP NUMBER
	SIGN(S) AND POST(S) INSTALLED BY ADAMS COUNTY

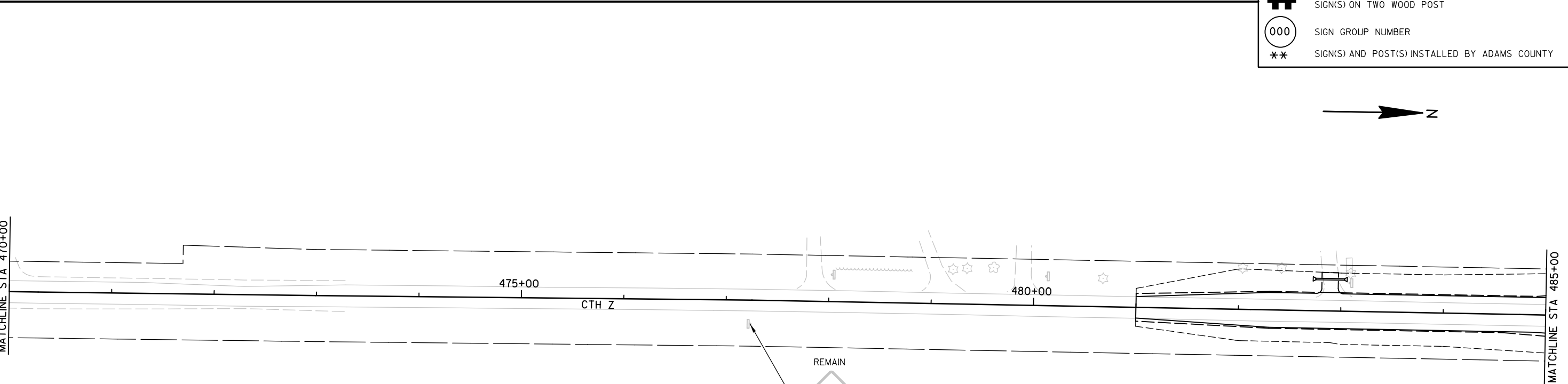

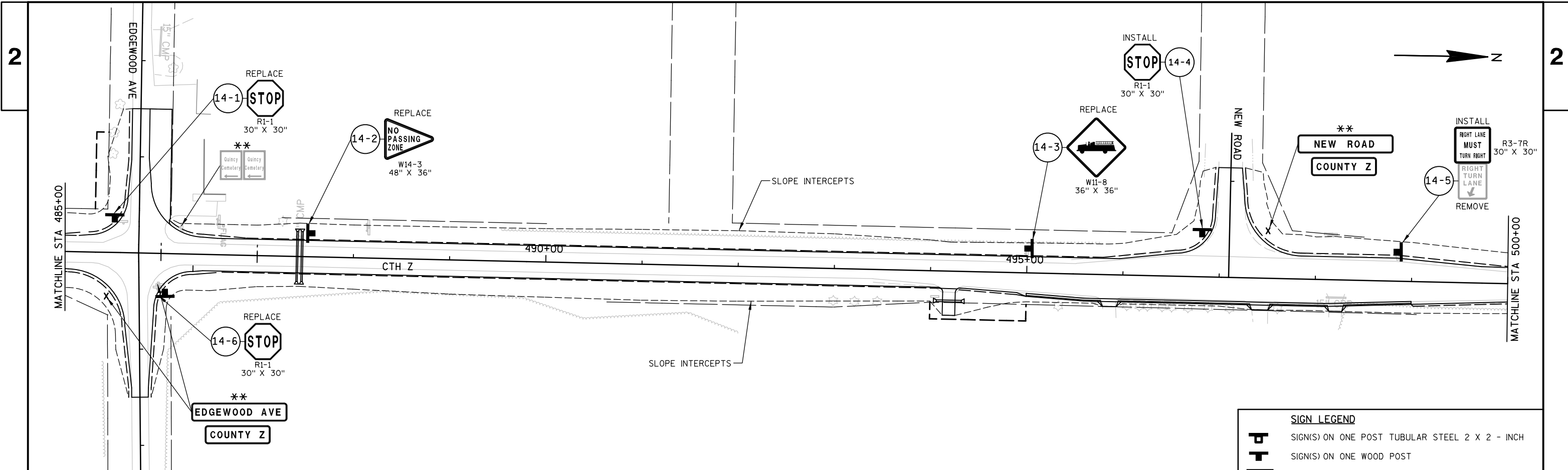

SIGN LEGEND

P	SIGN(S) ON ONE POST TUBULAR STEEL 2 X 2 - INCH
P	SIGN(S) ON ONE WOOD POST
P	SIGN(S) ON TWO WOOD POST
000	SIGN GROUP NUMBER
**	SIGN(S) AND POST(S) INSTALLED BY ADAMS COUNTY

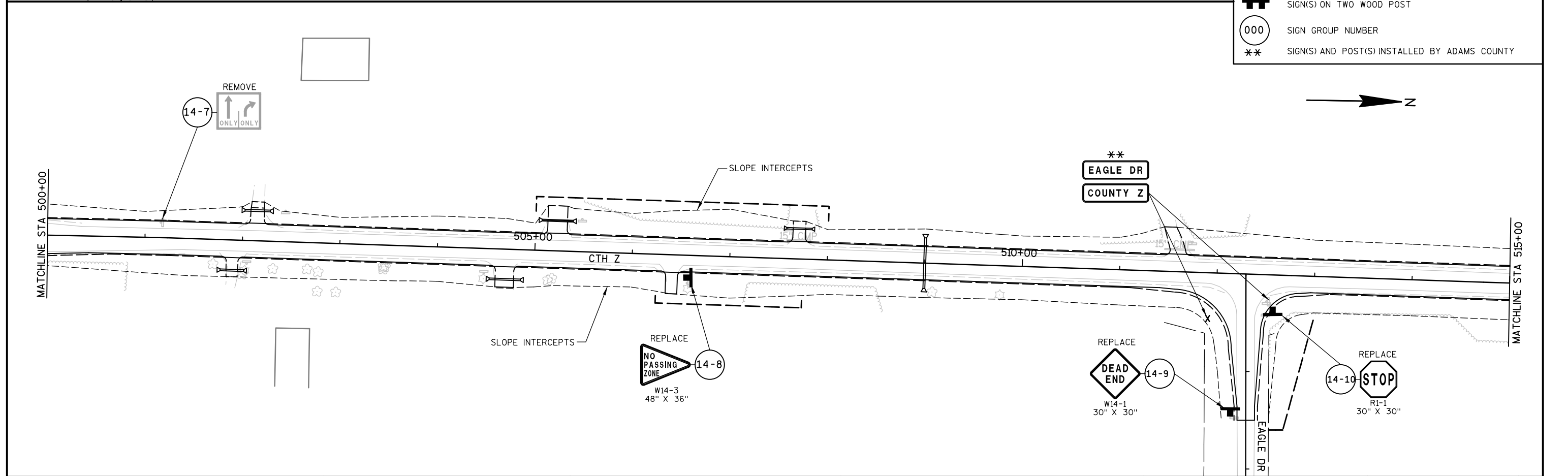

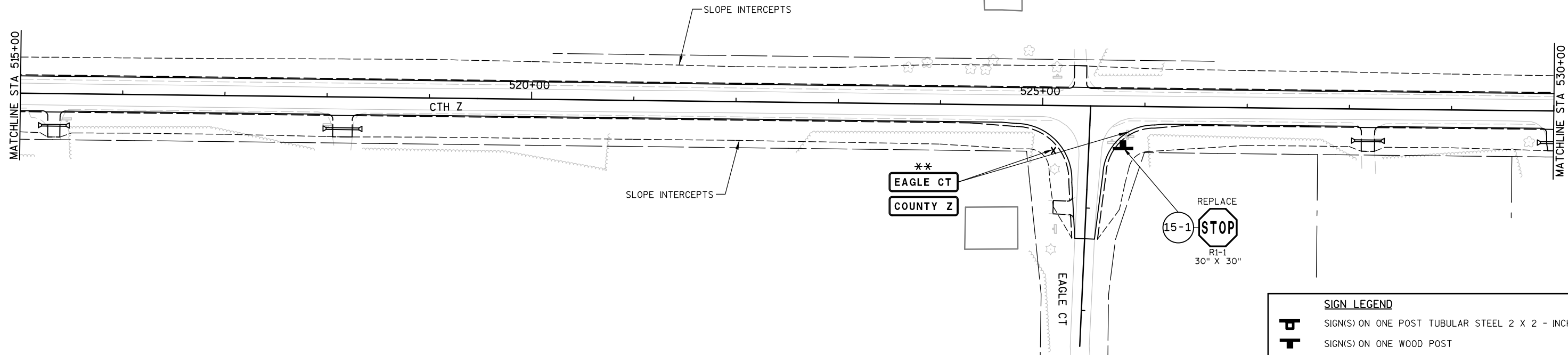
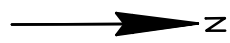

SIGN LEGEND

	SIGN(S) ON ONE POST TUBULAR STEEL 2 X 2 - INCH
	SIGN(S) ON ONE WOOD POST
	SIGN(S) ON TWO WOOD POST
	SIGN GROUP NUMBER
**	SIGN(S) AND POST(S) INSTALLED BY ADAMS COUNTY

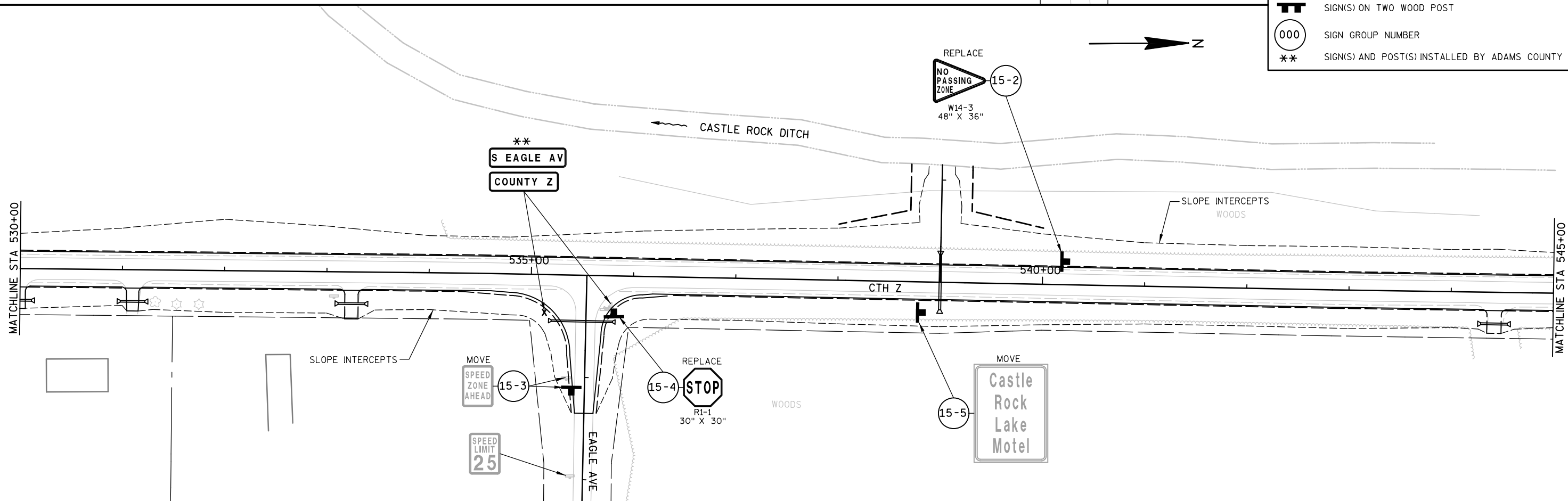

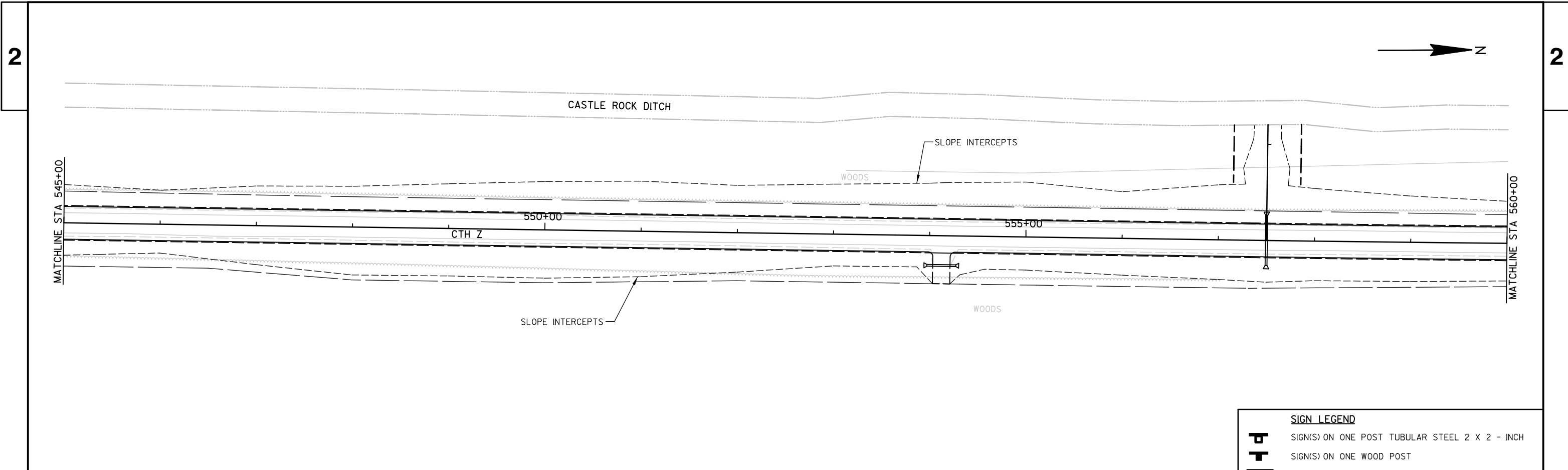

SIGN LEGEND	
	SIGN(S) ON ONE POST TUBULAR STEEL 2 X 2 - INCH
	SIGN(S) ON ONE WOOD POST
	SIGN(S) ON TWO WOOD POST
	SIGN GROUP NUMBER
	SIGN(S) AND POST(S) INSTALLED BY ADAMS COUNTY

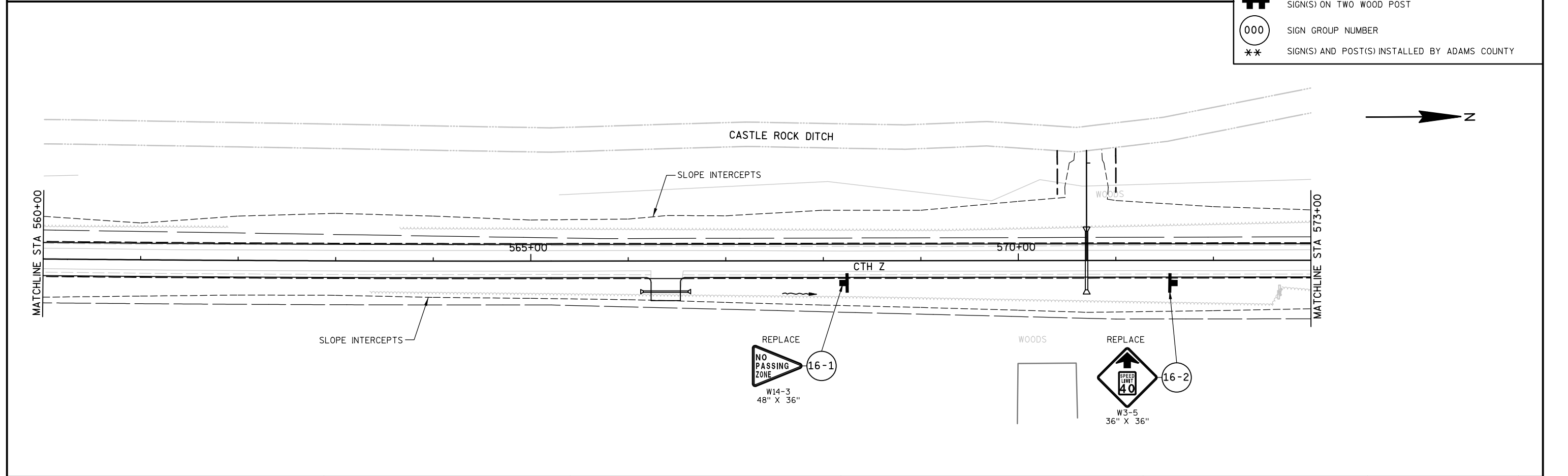

PROJECT NO: 6355-00-74	HWY: CTH Z	COUNTY: ADAMS	PERMANENT SIGNING	SCALE, FEET	SHEET	E
------------------------	------------	---------------	-------------------	-------------	-------	---

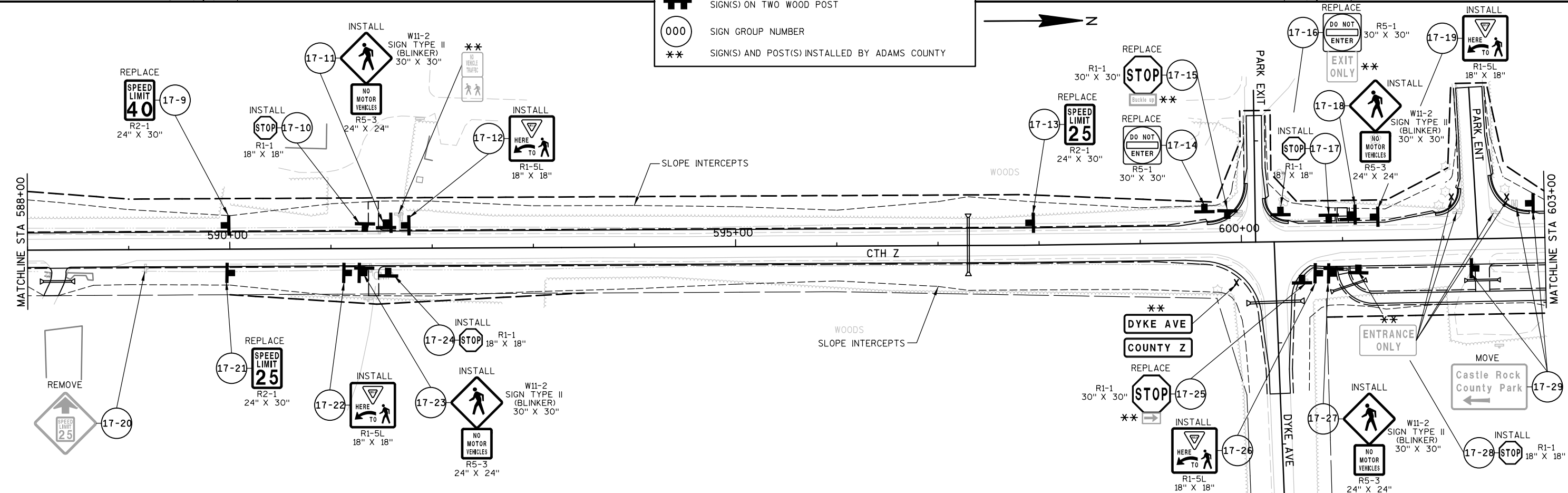
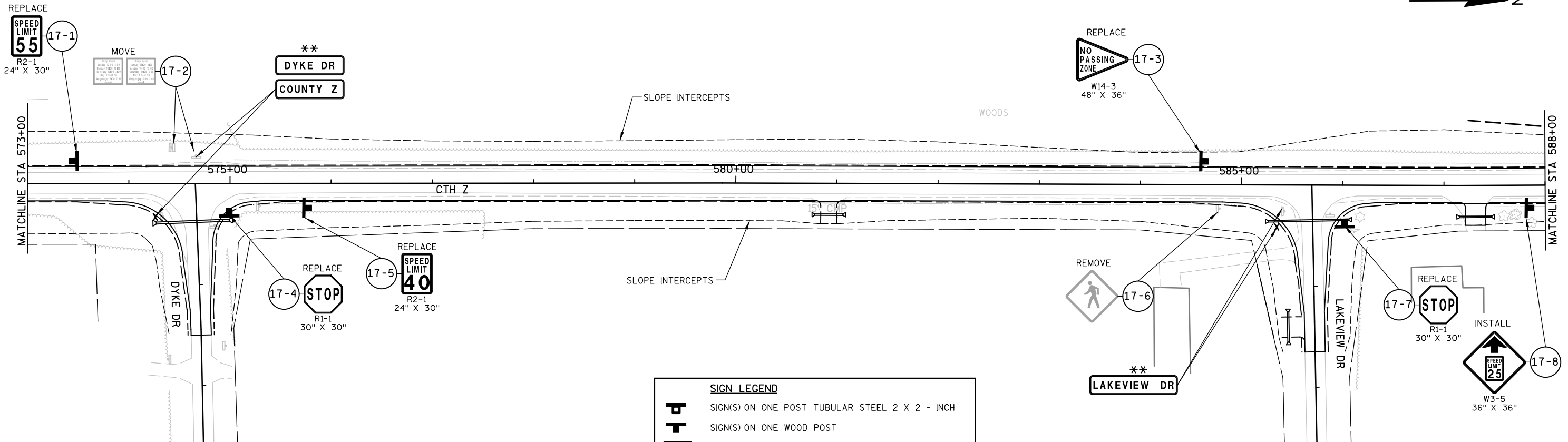

CASTLE ROCK LAKE

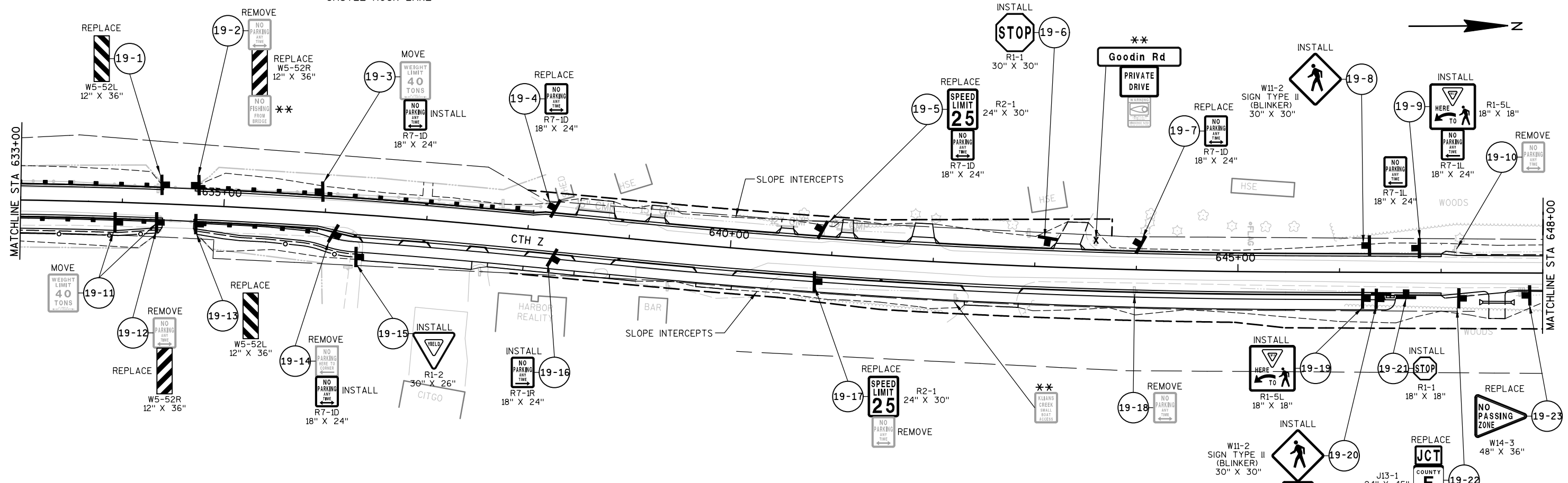

SIGN LEGEND

- SIGN(S) ON ONE POST TUBULAR STEEL 2 X 2 - INCH
- SIGN(S) ON ONE WOOD POST
- SIGN(S) ON TWO WOOD POST
- SIGN GROUP NUMBER
- SIGN(S) AND POST(S) INSTALLED BY ADAMS COUNTY

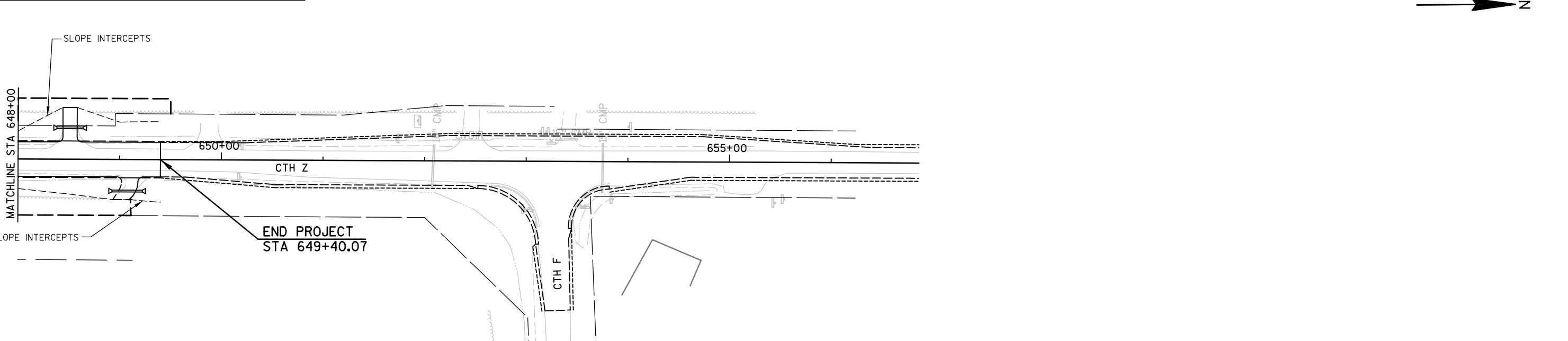

△ CP 27
 STA 501+83.46, 16.69' RT
 Y=187448.937
 X=499294.946
 1/4" REBAR 4± E OF E EOB
 & S EOG PE TO FIRE #2572

△ CP 28
 STA 512+30.87, 20.50' RT
 Y=188496.132
 X=499316.076
 PK NAIL 10± E OF E EOB
 & CL EAGLE DR TO E

△ CP 29
 STA 525+49.72, 21.20' RT
 Y=189814.771
 X=499339.511
 MAG NAIL 10± E OF E EOB
 & CL EAGLE CT TO E

△ CP 30
 STA 535+53.86
 Y=190818.607
 X=499356.368
 MAG NAIL 10± E OF E EOB
 & CL EAGLE AVE TO E

△ CP 31
 STA 550+42.56, 17.03' RT
 Y=192307.102
 X=499385.871
 1/4" REBAR 6± E OF E EOB
 & 10± W OF TEL PED #1717

△ CP 32
 STA 574+67.27, 15.01' RT
 Y=194731.871
 X=499411.541
 PK NAIL 4± E OF E EOB
 & CL DYK AVE TO E

△ CP 33
 STA 585+69.37, 17.49' RT
 Y=195833.858
 X=499421.495
 MAG NAIL 6± E OF E EOB
 & CL LAKE VIEW DR TO E

△ CP 34
 STA 600+32.53, 19.28' RT
 Y=197297.312
 X=499423.029
 PK NAIL 6± E OF E EOB
 & CL DYK AVE TO E

△ CP 35
 STA 610+83.77, 16.57' RT
 Y=198348.429
 X=499407.167
 1/4" REBAR 6± E OF E EOG
 & S LINE GREEN CABINS PUSHED
 W HIAWATHA MOTEL

△ CP 36
 STA 622+04.08, 18.07' RT
 Y=199468.052
 X=499414.804
 PK NAIL 6± E OF E EOB
 & CL DUCK DREEK DR TO E

△ CP 37
 STA 629+43.91, 19.55' RT
 Y=200208.478
 X=499424.364
 1/4" REBAR 6± E OF E EOB
 & 12± S OF WHITE PLASTIC
 POST @ S END BEAM GUARD

△ CP 38
 STA 637+58.78, 21.83' RT
 Y=201020.044
 X=499451.938
 PK NAIL 10± E OF E EOB &
 25± W OF HARBOR REALTY SIGN

△ CP 39
 STA 643+60.55, 14.81' RT
 Y=201621.479
 X=499491.197
 1/4" REBAR 4± E OF E EOB
 & 10' N OF MAIL BOXES

△ CP 40
 STA 652+91.62, 26.77' RT
 Y=202552.732
 X=499514.832
 PK NAIL 12± E OF E EOB
 & CL "F" TO E

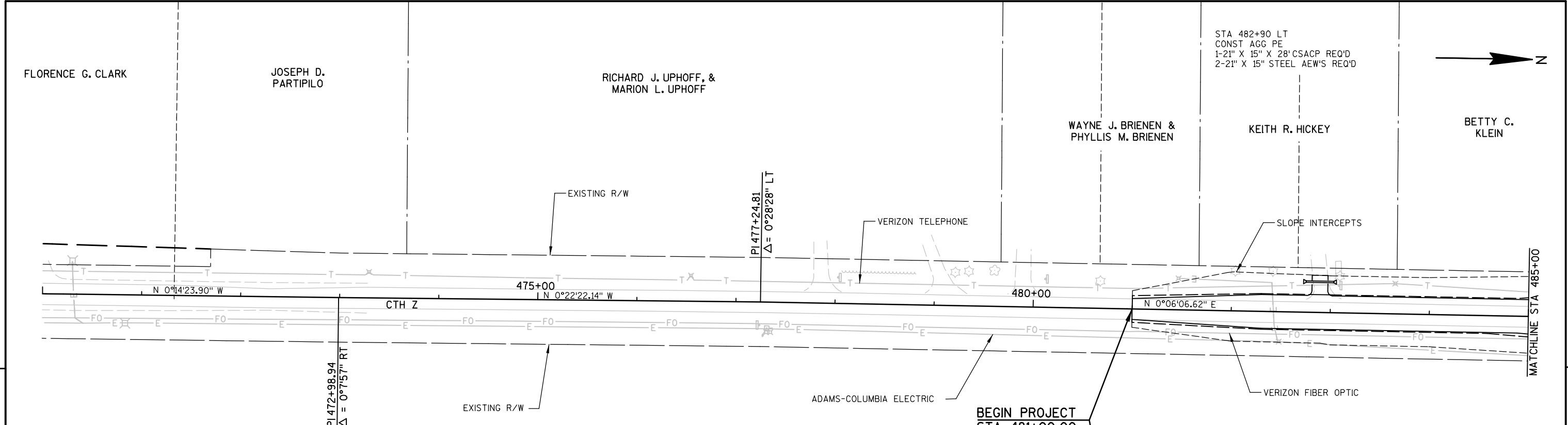

BENCHMARK TABLE

NO	STATION	DESCRIPTION	ELEV
25	486+97.86, 30.7' LT	FD ALUM CAP IN CONC POST NW COR EDGEWOOD AVE & CTH Z 33± N FLAG POLE	867.53

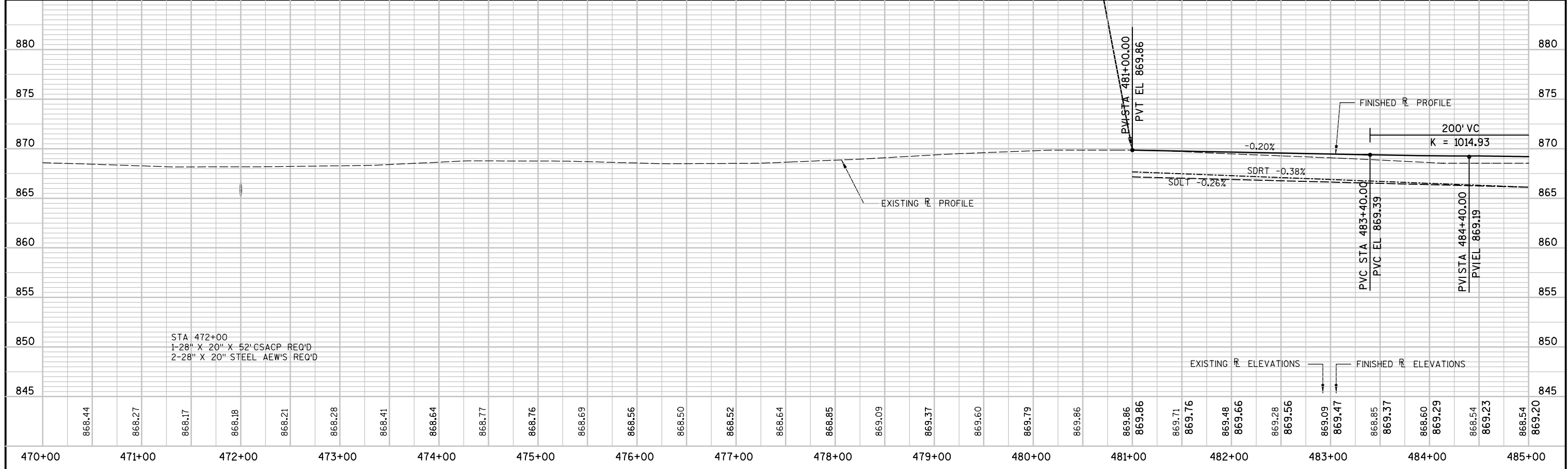

PROJECT NO: 6355-00-74 HWY: CTH Z COUNTY: ADAMS PLAN & PROFILE SCALE, FEET SHEET **E**

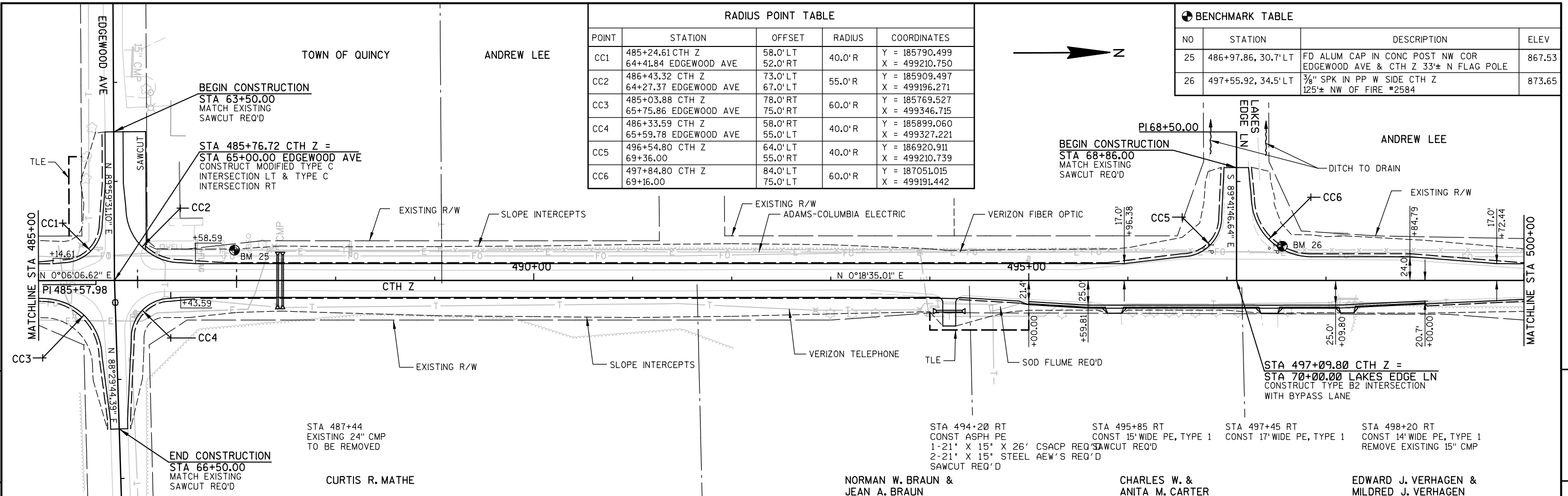

RADIUS POINT TABLE					
POINT	STATION	OFFSET	RADIUS	COORDINATES	
CC1	485+24.61 CTH Z 64+41.84 EDGEWOOD AVE	58.0' LT 52.0' RT	40.0' R	Y = 185790.499 X = 499210.750	
CC2	486+43.32 CTH Z 64+27.37 EDGEWOOD AVE	73.0' LT 67.0' LT	55.0' R	Y = 185909.497 X = 499196.271	
CC3	485+03.88 CTH Z 65+75.86 EDGEWOOD AVE	78.0' RT 75.0' RT	60.0' R	Y = 185769.527 X = 499346.715	
CC4	486+33.59 CTH Z 65+59.78 EDGEWOOD AVE	58.0' RT 55.0' LT	40.0' R	Y = 185899.060 X = 499327.221	
CC5	496+54.80 CTH Z 69+36.00	64.0' LT 55.0' RT	40.0' R	Y = 186920.911 X = 499210.739	
CC6	497+84.80 CTH Z 69+16.00	84.0' LT 75.0' LT	60.0' R	Y = 187051.015 X = 499191.442	

BENCHMARK TABLE			
NO	STATION	DESCRIPTION	ELEV
25	486+97.86, 30.7' LT	FD ALUM CAP IN CONC POST NW COR EDGEWOOD AVE & CTH Z 33'± N FLAG POLE	867.53
26	497+55.92, 34.5' LT	3/4" SPK IN PP W SIDE CTH Z 125'± NW OF FIRE #2584	873.65

5

5

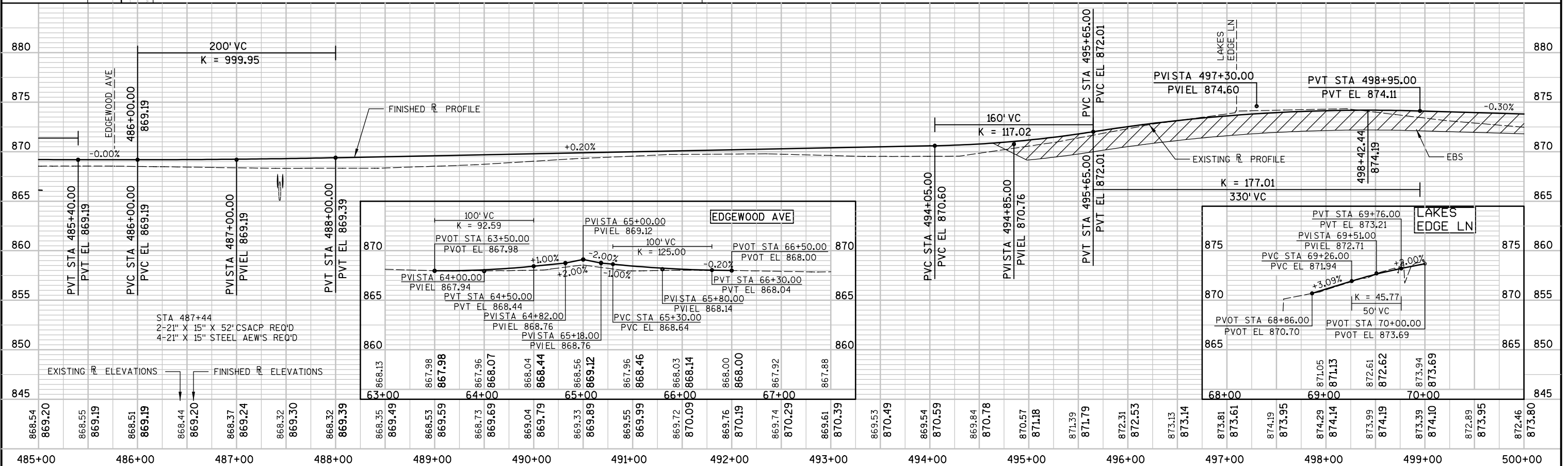

PROJECT NO: 6355-00-74	HWY: CTH Z	COUNTY: ADAMS	PLAN & PROFILE	SCALE, FEET	SHEET	E
------------------------	------------	---------------	----------------	-------------	-------	---

RONALD A. TAYLOR

RAYMOND J. COLLINS & PAMELA J. KOEPKE

ZACHARY J. FENSKE

RADIUS POINT TABLE

POINT	STATION	OFFSET	RADIUS	COORDINATES
CC1	511+57.06 CTH Z 75+75.58 EAGLE DRIVE	78.0' RT 75.0' RT	60.0' R	Y = 188421.336 X = 499372.307
CC2	512+86.47 CTH Z 75+59.86 EAGLE DRIVE	58.0' RT 55.0' LT	40.0' R	Y = 188551.072 X = 499354.539

BENCHMARK TABLE

NO	STATION	DESCRIPTION	ELEV
27	512+08.74, 30.0' LT	3/8" SPK IN PP# R2748 W SIDE CTH Z & EAGLE DRIVE 50'+ N OF FIRE #2551	871.58

STA 502+15 LT
CONST AGG PE
1-21" X 15" X 26' CSACP REQ'D
2-21" X 15" STEEL AEW'S REQ'D

STA 505+20 LT
CONST AGG PE
1-21" X 15" X 32' CSACP REQ'D
2-21" X 15" STEEL AEW'S REQ'D

STA 507+70 LT
CONST AGG PE
REMOVE EXISTING 15" CMP
1-21" X 15" X 26' CSACP REQ'D
2-21" X 15" STEEL AEW'S REQ'D

STA 511+55 LT
CONST AGG PE
REMOVE EXISTING 15" CMP

STA 512+29.53 CTH Z =
STA 75+00.00 EAGLE DR
CONSTRUCT TYPE C INTERSECTION

STA 501+90 RT
CONST AGG PE
1-21" X 15" X 24' CSACP REQ'D
2-21" X 15" STEEL AEW'S REQ'D

STA 504+70 RT
CONST AGG PE
1-21" X 15" X 32' CSACP REQ'D
2-21" X 15" STEEL AEW'S REQ'D

STA 506+40 RT
CONST ASPH PE
SAWCUT REQ'D

END CONSTRUCTION
STA 76+50.00
MATCH EXISTING
SAWCUT REQ'D

JEFFREY A. STATEMA &
CHRISTINA R. STATEMA

THOMAS C. MORGAN

DANNY E. GIESSEL & JULIE A. DAVIS

THOMAS C. MORGAN

RAYMOND SOTO & CINDY L. SOTO

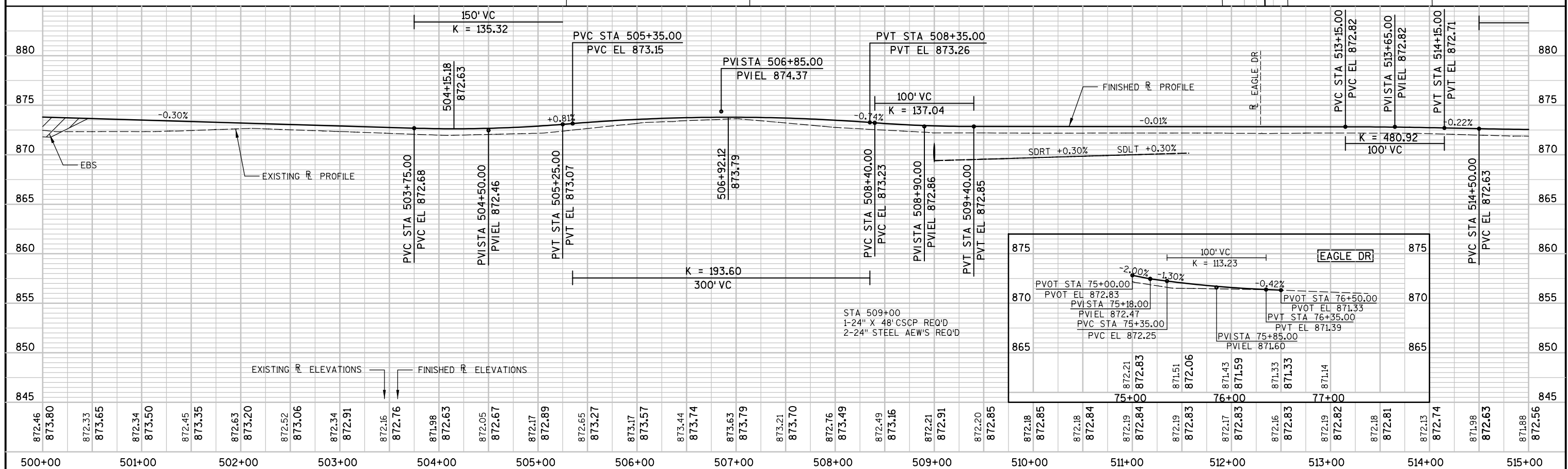

WISCONSIN RIVER POWER COMPANY

HAROLD R. FELDMAN

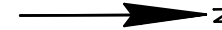

RADIUS POINT TABLE

POINT	STATION	OFFSET	RADIUS	COORDINATES
CC1	524+74.44 CTH Z 80+75.41 EAGLE CT	73.0' RT 70.0' RT	55.0' R	Y = 189738.611 X = 499390.000
CC2	526+09.69 CTH Z 80+65.83 EAGLE CT	68.0' RT 65.0' LT	50.0' R	Y = 189873.923 X = 499387.331

BENCHMARK TABLE

NO	STATION	DESCRIPTION	ELEV
28	524+97.68, 28.6' LT	3/8" SPK IN PP SW COR CTH Z & EAGLE CT @ FIRE #2537	875.04

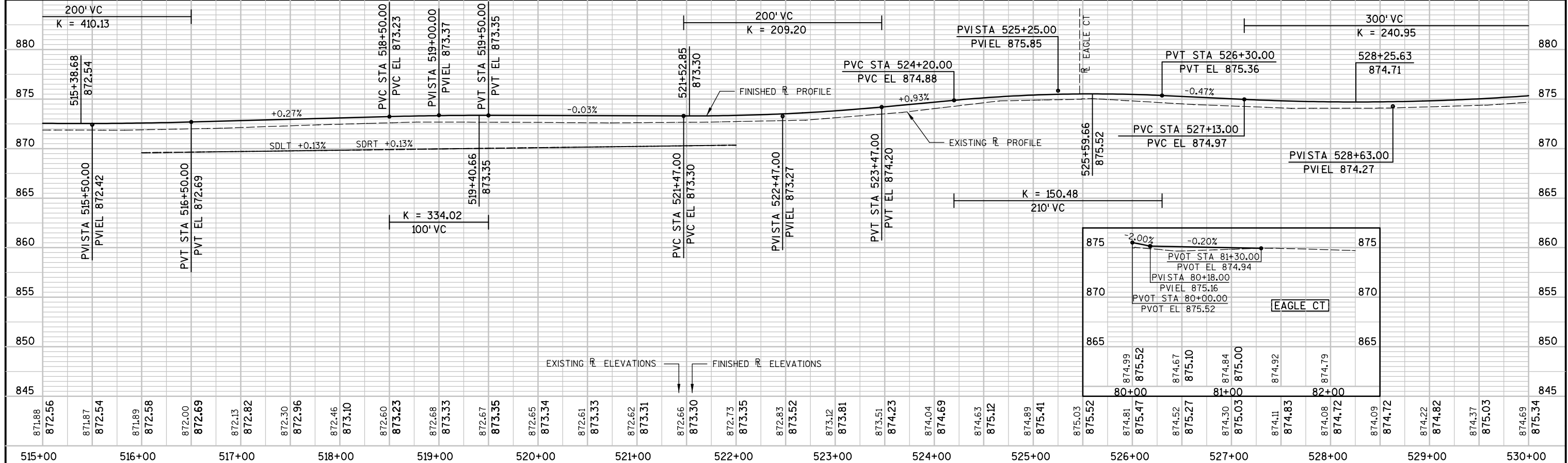
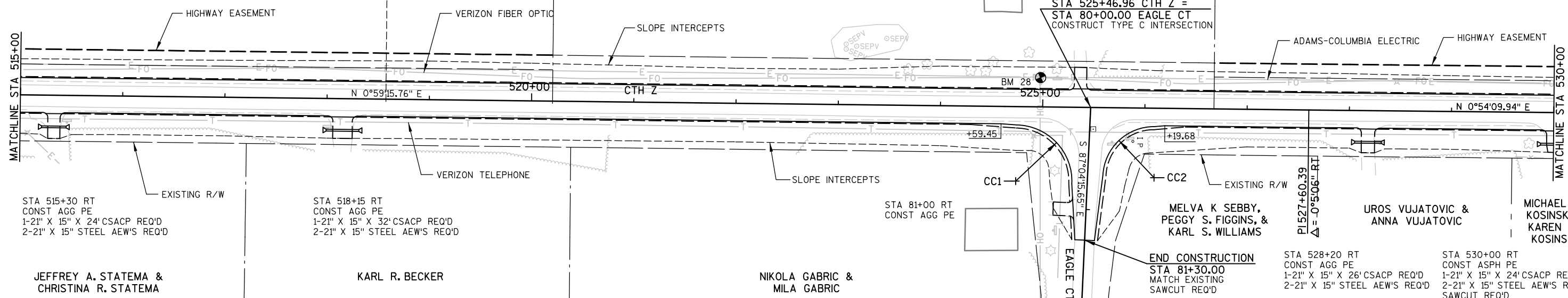

PROJECT NO: 6355-00-74 HWY: CTH Z COUNTY: ADAMS PLAN & PROFILE SCALE, FEET SHEET **E**

RADIUS POINT TABLE				
POINT	STATION	OFFSET	RADIUS	COORDINATES
CC1	534+79.17 CTH Z 85+78.15 EAGLE AVENUE	78.0' RT 75.0' RT	60.0' R	Y = 190742.513 X = 499411.522
CC2	536+09.20 CTH Z 85+57.88 EAGLE AVENUE	58.0' RT 55.0' LT	40.0' R	Y = 190873.012 X = 499394.764

BENCHMARK TABLE			
NO	STATION	DESCRIPTION	ELEV
29	538+80.60, 28.9' RT	3/8" SPK IN SIGN POST CASTLE ROCK LK MOTEL SIGN E SIDE CTH Z 250'± N EAGLE AVE	873.73

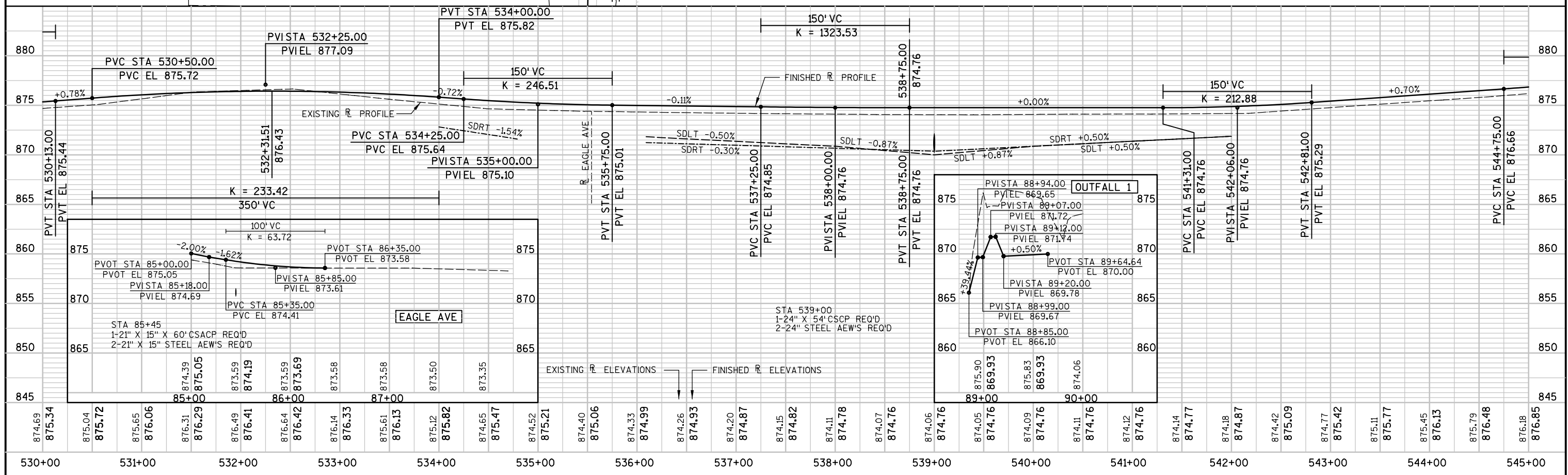
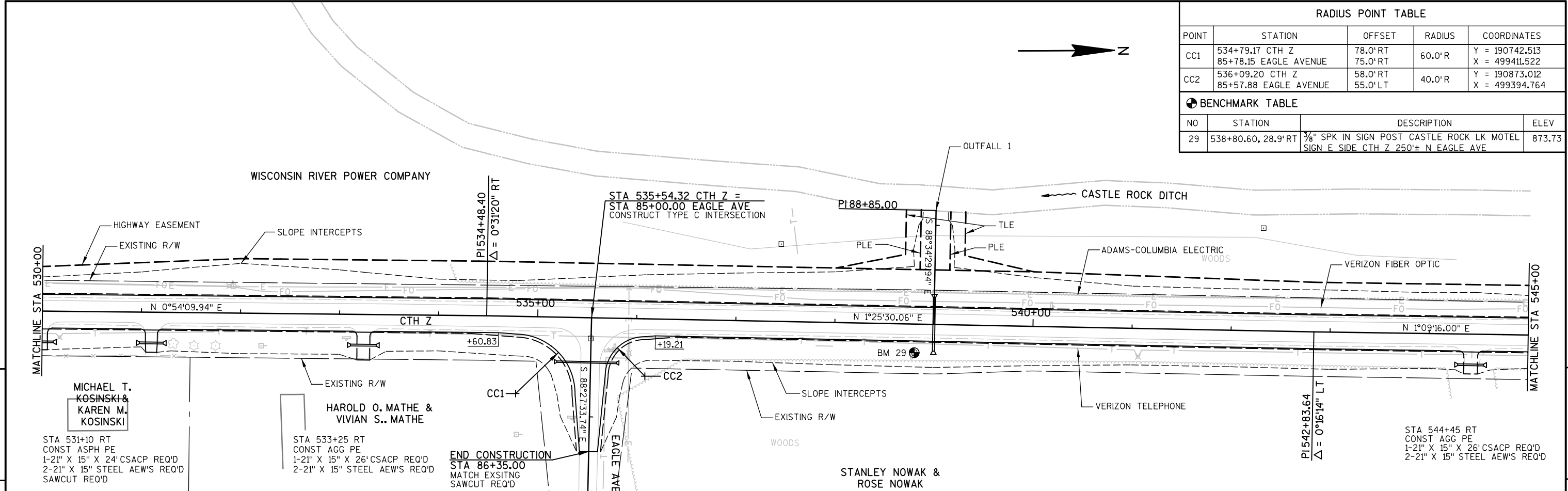

PROJECT NO: 6355-00-74 HWY: CTH Z COUNTY: ADAMS PLAN & PROFILE SCALE, FEET 0 50 100 SHEET E

WISCONSIN RIVER POWER COMPANY

CURVE DATA
 DELTA = 0°54'16.00" (LT)
 D = 0°06'52.53"
 T = 394.65
 L = 789.28
 E = 156
 R = 50000.00
 DB = N 1°09'16.00" E
 DA = N 0°15'00.00" E
 PC STA 557+31.66
 PC Y = 192996.409
 PC X = 499382.731
 PISTA 561+26.31
 PI Y = 193390.975
 PI X = 499390.682
 PT STA 565+20.94
 PT Y = 193785.618
 PT X = 499392.404
 SE = NC

BENCHMARK TABLE

NO	STATION	DESCRIPTION	ELEV
30	556+74.23, 45.9' RT	3/8" SPK IN 12" PINE E SIDE CTH Z 15± E OF TELE PED# 1716	877.97

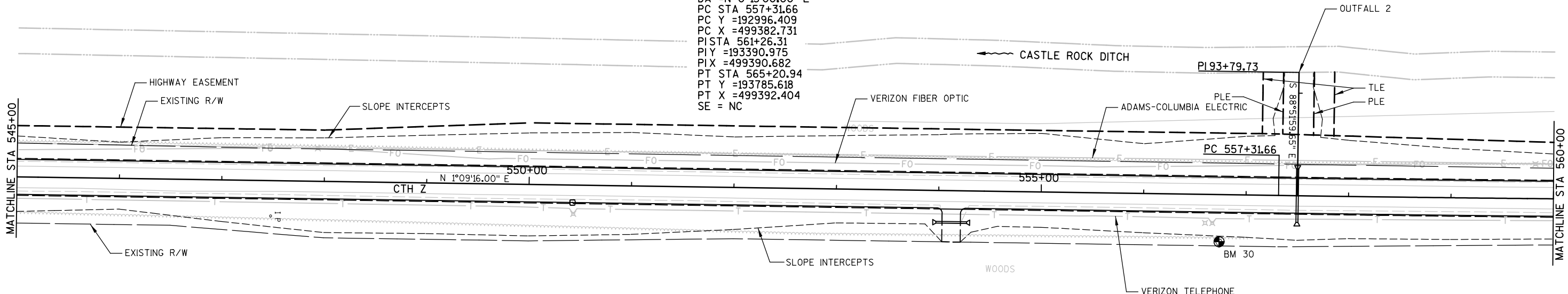

STA 554+15 RT
 CONST AGG PE
 1-21" X 15" X 30' CSACP REQ'D
 2-21" X 15" STEEL AEW'S REQ'D

PLUM CREEK LAND COMPANY

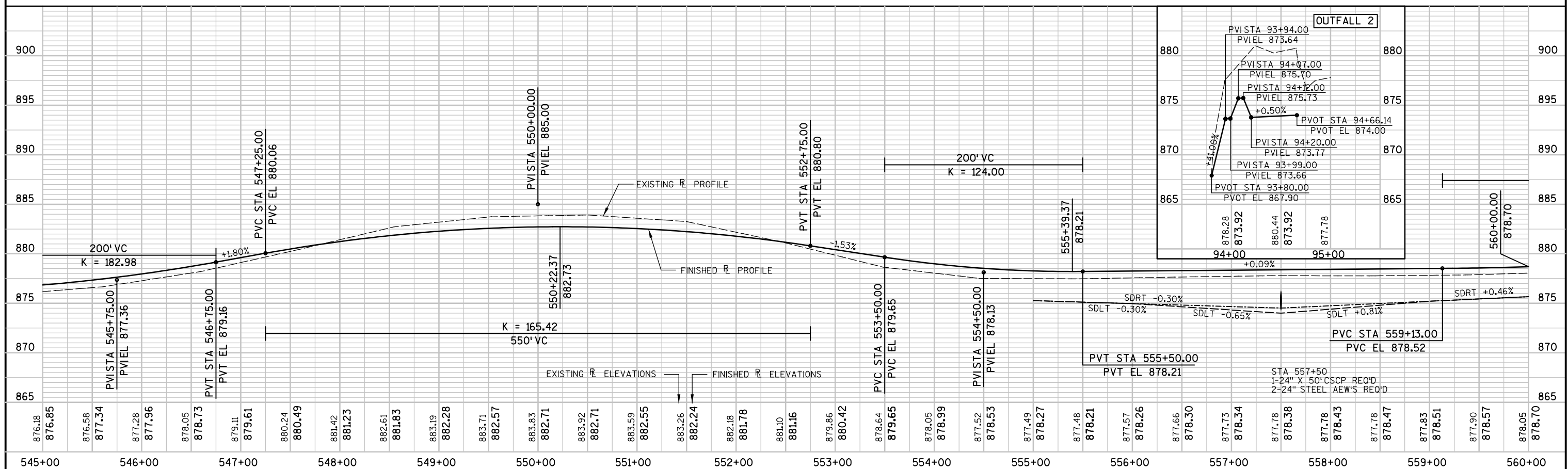

CURVE DATA
 DELTA = 0°54'16.00" (LT)
 D = 0°06'52.53"
 T = 394.65
 L = 789.28
 E = 1.56
 R = 50000.00
 DB = N 1°09'16.00" E
 DA = N 0°15'00.00" E
 PC STA 557+31.66
 PC Y = 192996.409
 PC X = 499382.731
 PISTA 561+26.31
 PIY = 193390.975
 PIX = 499390.682
 PT STA 565+20.94
 PT Y = 193785.618
 PT X = 499392.404
 SE = NC

BENCHMARK TABLE			
NO	STATION	DESCRIPTION	ELEV
30	556+74.23, 45.9' RT	3/8" SPK IN 12" PINE E SIDE CTH Z 15± E OF TELE PED# 1716	877.97

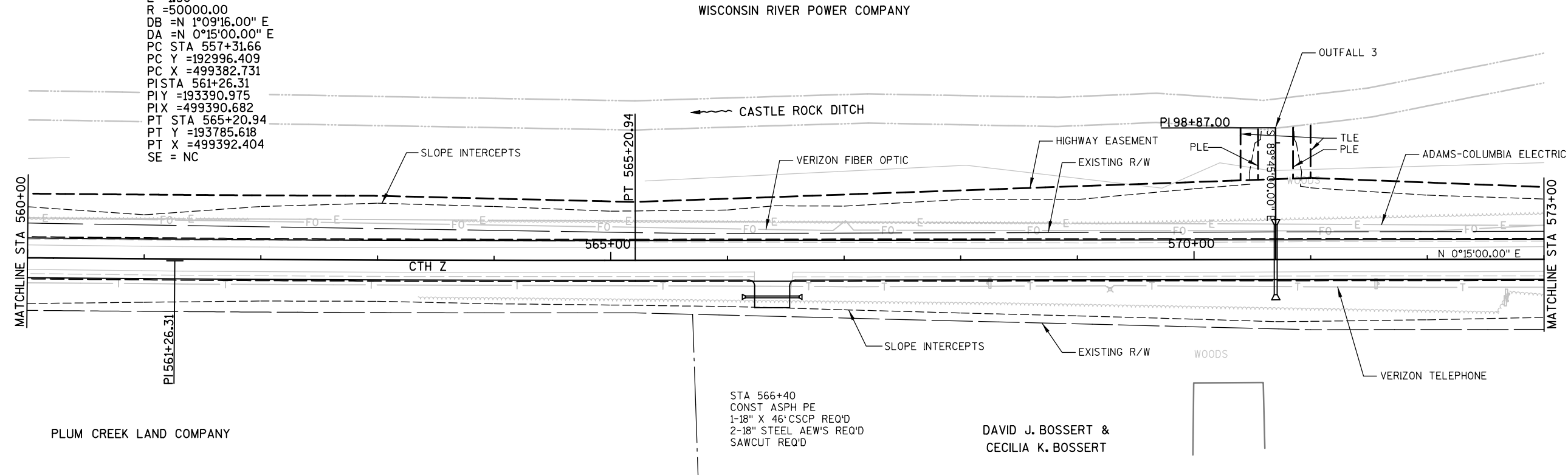

5

5

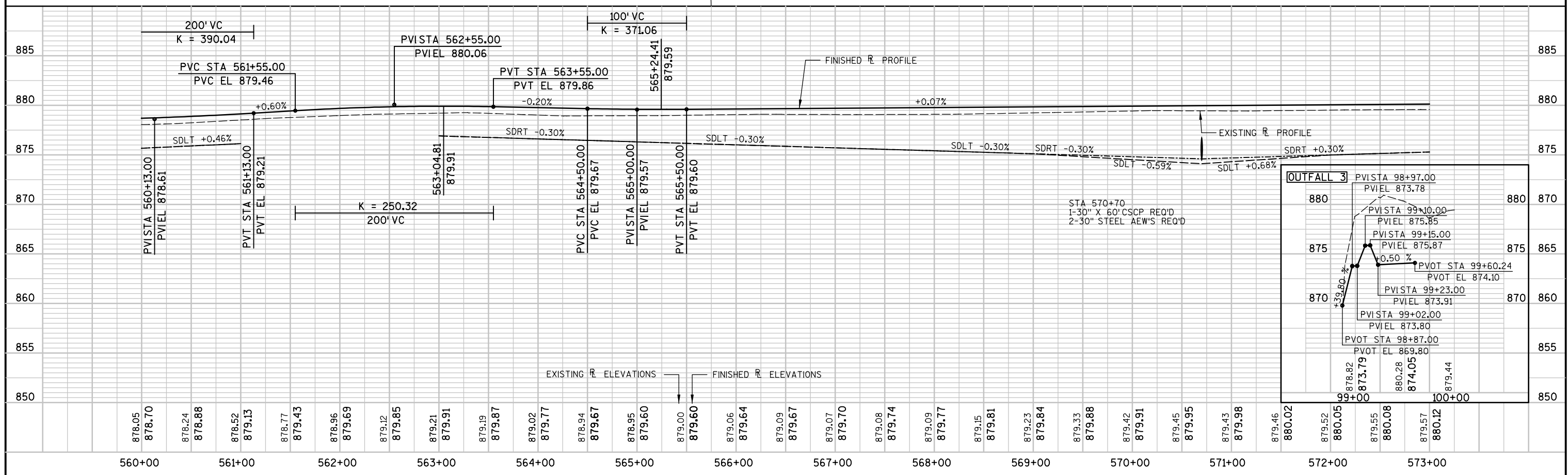

PROJECT NO: 6355-00-74 HWY: CTH Z COUNTY: ADAMS PLAN & PROFILE SCALE, FEET 0 50 100 SHEET E

RADIUS POINT TABLE				
POINT	STATION	OFFSET	RADIUS	COORDINATES
CC1	573+93.68 CTH Z 105+75.19 DYKE DRIVE	78.0' RT 75.0' RT	60.0' R	Y = 194658.014 X = 499474.220
CC2	575+23.01 CTH Z 105+60.16 DYKE DRIVE	58.0' RT 55.0' LT	40.0' R	Y = 194787.428 X = 499454.786
CC3	584+96.23 CTH Z 110+76.31 LAKEVIEW DRIVE	78.0' RT 75.0' RT	60.0' R	Y = 195760.176 X = 499481.360
CC4	586+25.80 CTH Z 110+59.29 LAKEVIEW DRIVE	58.0' RT 55.0' LT	40.0' R	Y = 195889.926 X = 499462.518

BENCHMARK TABLE			
NO	STATION	DESCRIPTION	ELEV
32	577+08.05, 29.1' LT	3/8" SPK IN PP# D228 W SIDE CTH Z 200'± N OF DYK DRIVE	879.29
33	587+36.47, 30.5' LT	3/8" SPK IN PP W SIDE CTH Z 75'± W OF FIRE #2424	888.72

WISCONSIN RIVER POWER COMPANY

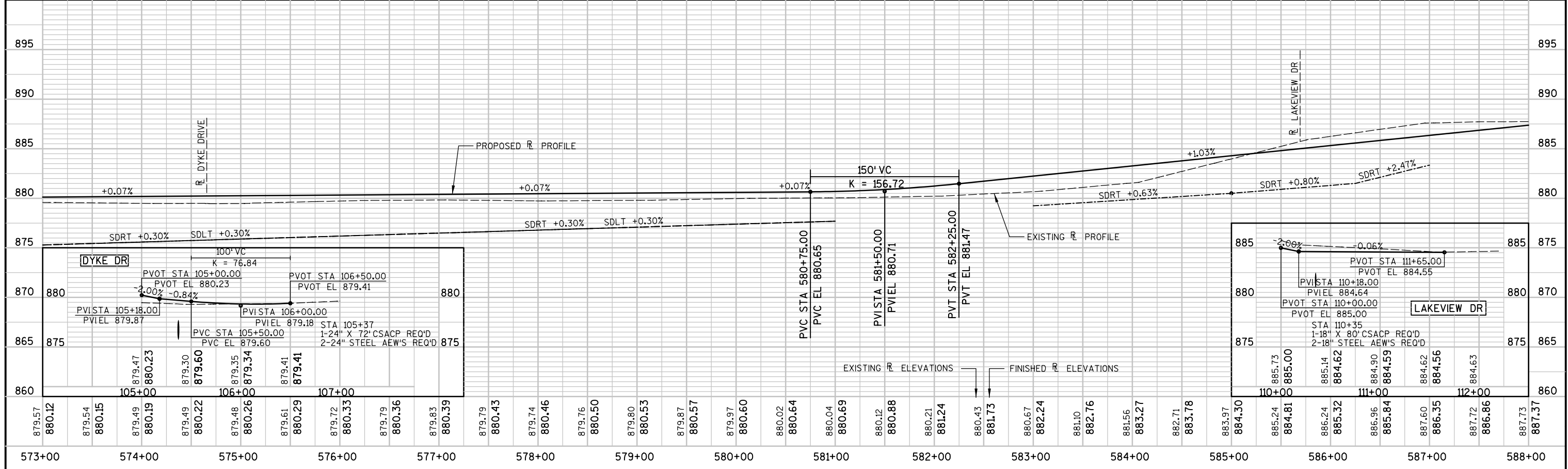
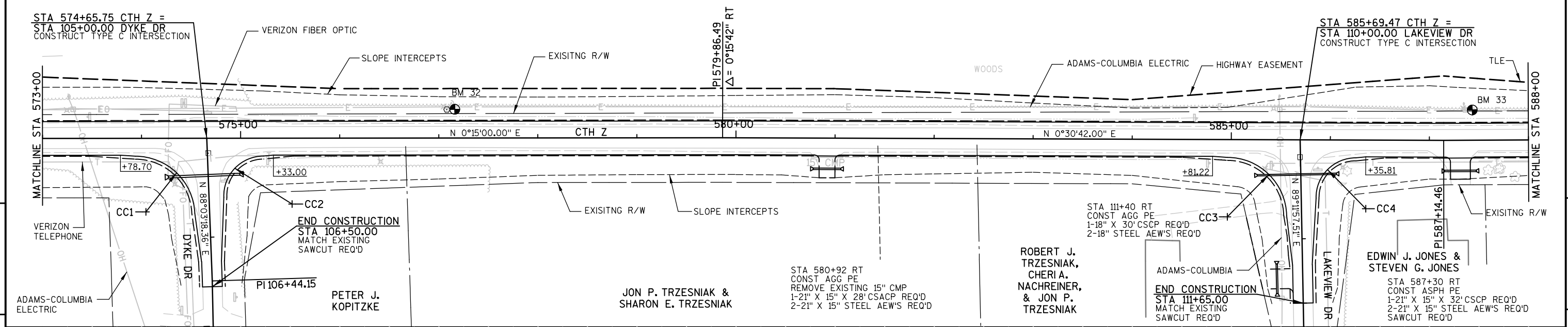
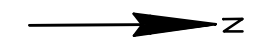

PROJECT NO: 6355-00-74 HWY: CTH Z COUNTY: ADAMS PLAN & PROFILE SCALE, FEET 0 50 100 SHEET E

RADIUS POINT TABLE				
POINT	STATION	OFFSET	RADIUS	COORDINATES
CC1	599+59.41 CTH Z 120+76.05 DYKE AVE	78.0' RT 75.0' RT	60.0' R	Y = 197224.674 X = 499482.347
CC2	600+88.93 CTH Z 120+59.47 DYKE AVE	58.0' RT 55.0' LT	40.0' R	Y = 197354.024 X = 499461.285
CC3	601+30.00 CTH Z 120+29.56 DYKE AVE	27.0' RT 96.9' LT	25.0' R	Y = 197394.847 X = 499429.949

BENCHMARK TABLE			
NO	STATION	DESCRIPTION	ELEV
34	599+75.72, 47.0' RT	3/8" SPK IN 14" RED PINE SE COR DYK AVE & CTH Z	887.96



ADAMS COUNTY

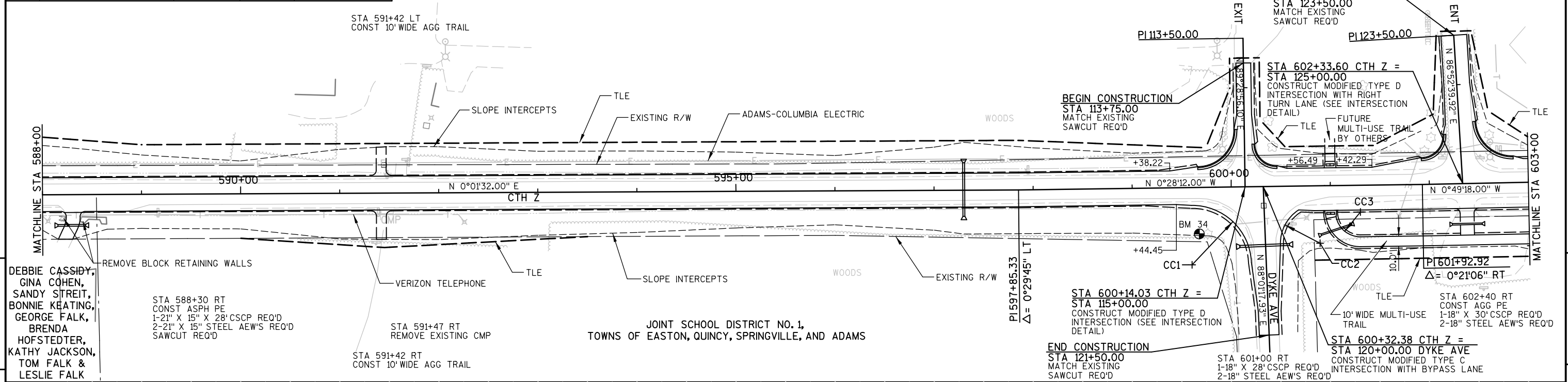

5
DEBBIE CASSIDY,
GINA COHEN,
SANDY STREIT,
BONNIE KEATING,
GEORGE FALK,
BRENDA
HOFSTEDTER,
KATHY JACKSON,
TOM FALK &
LESLIE FALK

5

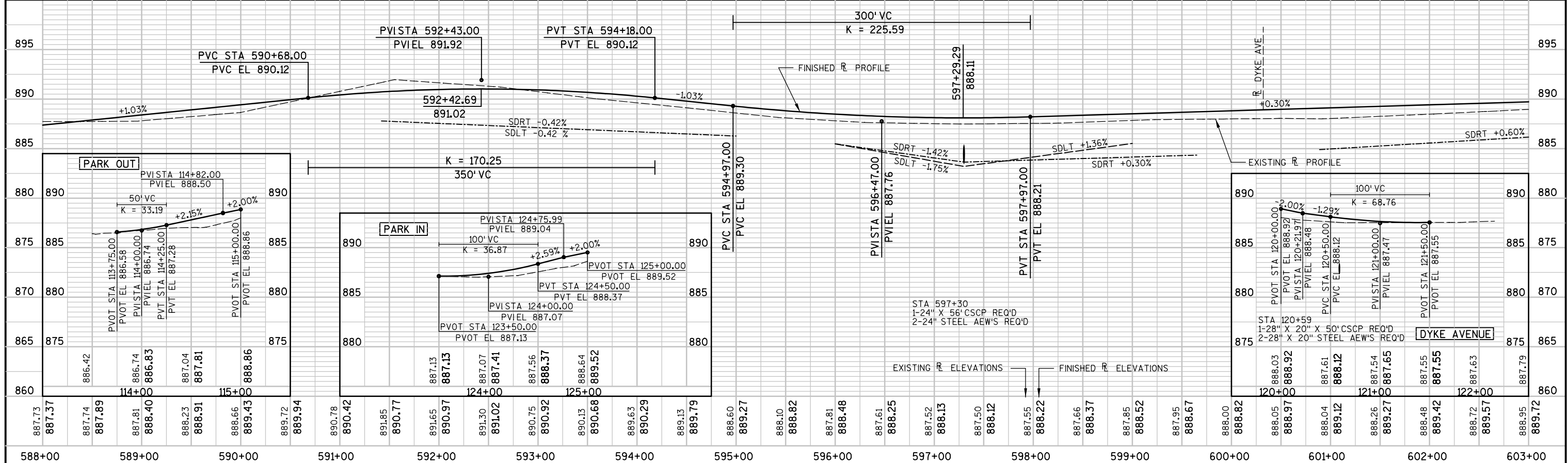

BENCHMARK TABLE				
NO	STATION	DESCRIPTION	ELEV	
35	609+71.53, 24.2' LT	3/8" SPK IN PP# 2 W SIDE OF CTH Z 150'± SW OF NIAWATHA MOTEL	895.45	

RADIUS POINT TABLE				
POINT	STATION	OFFSET	RADIUS	COORDINATES
CC1	604+50.01 CTH Z	2.0' RT	50.0' R	Y=197714.635 X=499400.747
CC2	605+22.78 CTH Z	84.5' RT	50.0' R	Y=197788.584 X=499482.181

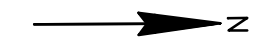

ADAMS COUNTY

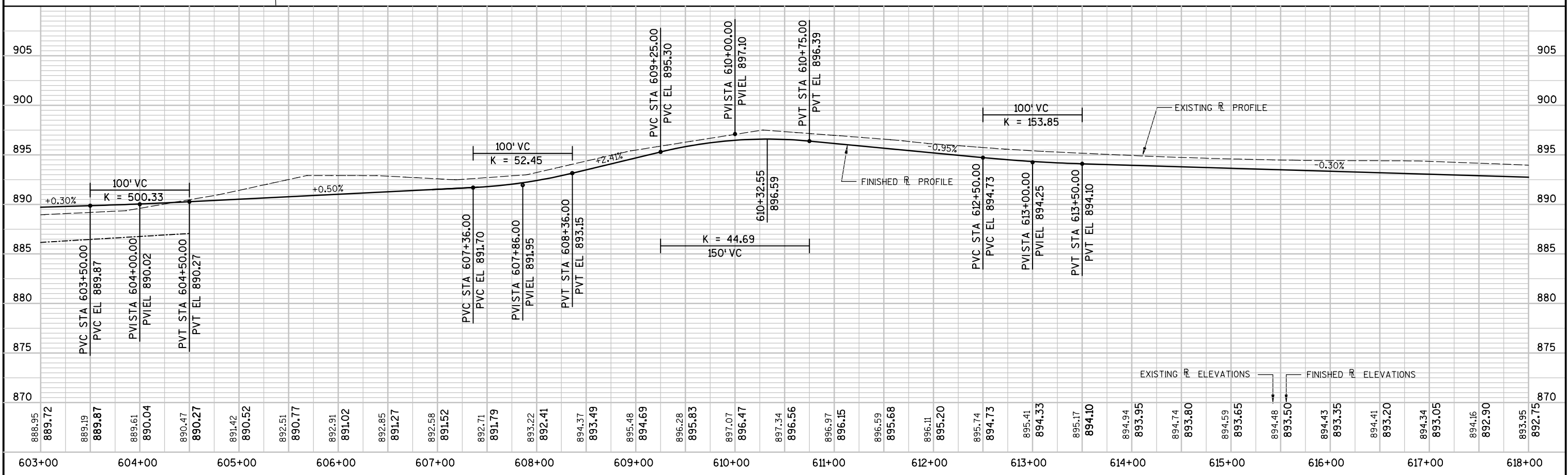
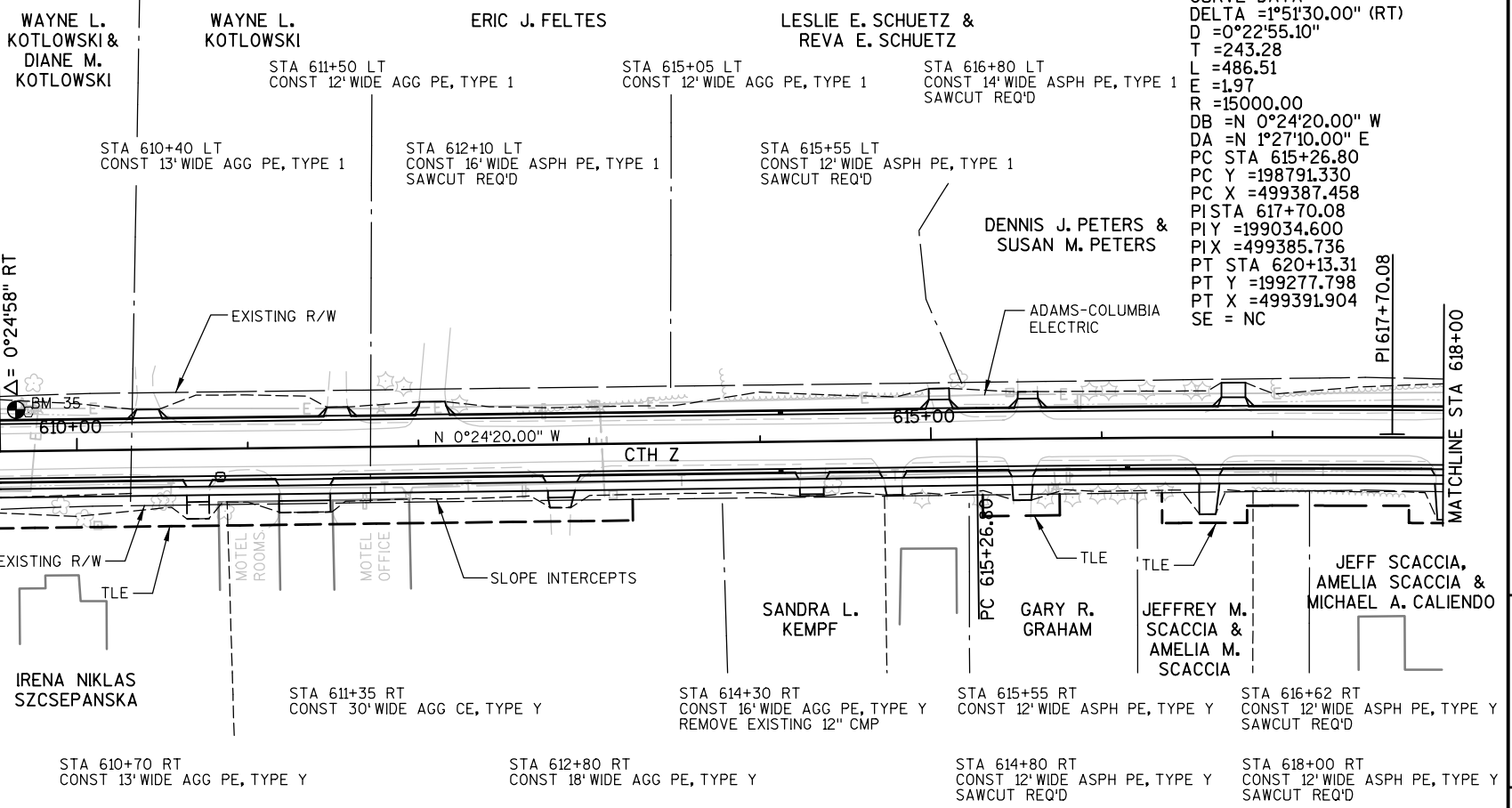

PROJECT NO: 6355-00-74	HWY: CTH Z	COUNTY: ADAMS	PLAN & PROFILE	SCALE, FEET	SHEET	E
------------------------	------------	---------------	----------------	-------------	-------	----------

BENCHMARK TABLE			
NO	STATION	DESCRIPTION	ELEV
36	621+09.81, 22.8' LT	3/8" SPK IN PP W SIDE CTH Z & 100'± S OF DUCK CREEK DRIVE	889.53

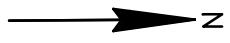

CURVE DATA DELTA = 1°51'30.00" (RT)
 D = 0°22'55.10"
 T = 243.28
 L = 486.51
 E = 1.97
 R = 15000.00
 DB = N 0°24'20.00" W
 DA = N 1°27'10.00" E
 PC STA 615+26.80
 PC Y = 198791.330
 PC X = 499387.458
 PISTA 617+70.08
 PIY = 199034.600
 PIX = 499385.736
 PT STA 620+13.31
 PT Y = 199277.798
 PT X = 499391.904
 SE = NC

CURVE DATA DELTA = 2°30'06.00" (LT)
 D = 0°22'55.10"
 T = 327.52
 L = 654.93
 E = 3.58
 R = 15000.00
 DB = N 1°27'10.00" E
 DA = N 1°02'56.00" W
 PC STA 623+77.92
 PC Y = 199642.287
 PC X = 499401.147
 PISTA 627+05.44
 PIY = 199969.701
 PIX = 499409.451
 PT STA 630+32.85
 PT Y = 200297.166
 PT X = 499403.456
 SE = NC

SAMUEL KIMBROUGH, GRANT R. SLAYTON, LAWRENCE R. FRICK & MARGARET R. FRICK, RANDOLPH R. RURUP & CHRISTINE F. RURUP, TIMOTHY J. FOSTER, JOHN T. HAUGH, DEAN F. KAMPA & KATHLENE T. KAMPA

CURVE DATA DELTA = 6°51'36.00" (RT)
 D = 0°57'17.75"
 T = 359.62
 L = 718.38
 E = 10.77
 R = 6000.00
 DB = N 1°02'56.00" W
 DA = N 5°48'40.00" E
 PC STA 630+65.34
 PC Y = 200329.651
 PC X = 499402.861
 PISTA 634+24.96
 PIY = 200689.209
 PIX = 499396.278
 PT STA 637+83.72
 PT Y = 201046.980
 PT X = 499432.689
 SE = NC

JASON SCHULS

STA 622+05.65 CTH Z =
 STA 130+00.00 DUCK CREEK DR
 CONSTRUCT MODIFIED TYPE D INTERSECTION
 (SEE INTERSECTION DETAIL)

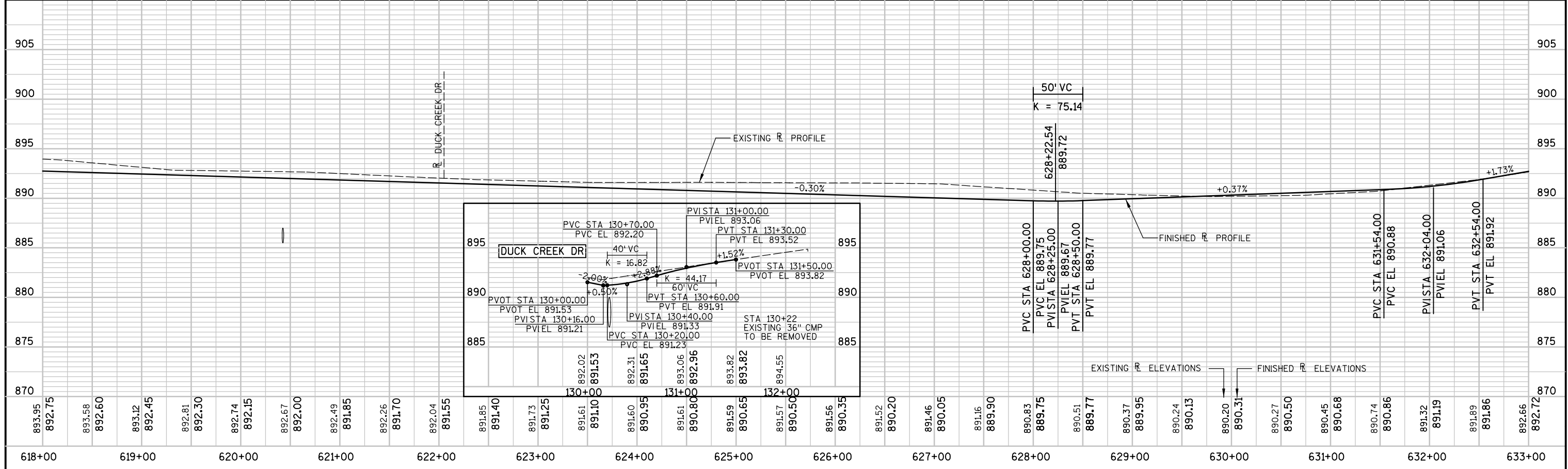
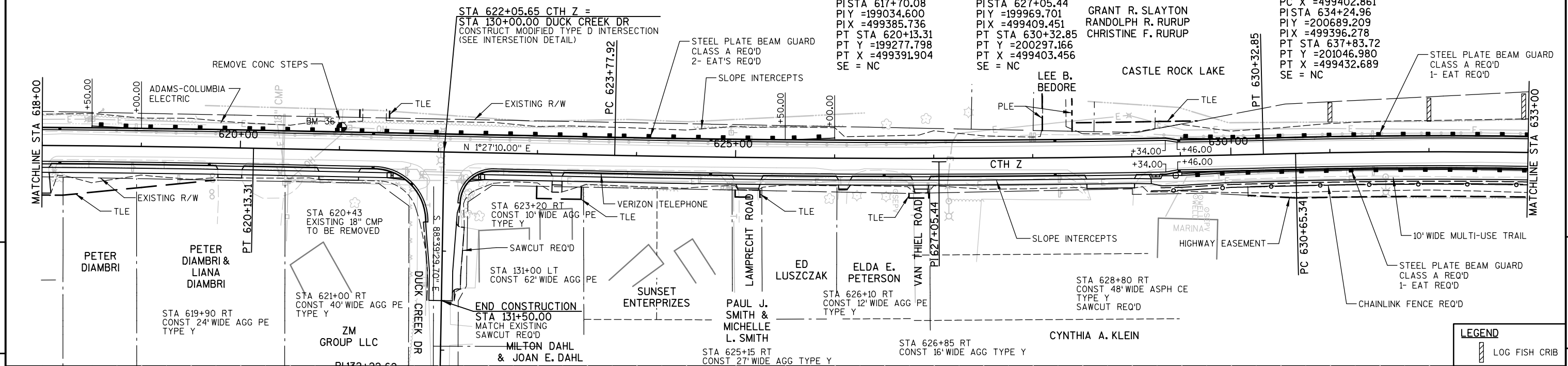

PROJECT NO: 6355-00-74	HWY: CTH Z	COUNTY: ADAMS	PLAN & PROFILE	SCALE, FEET	SHEET	E
------------------------	------------	---------------	----------------	-------------	-------	----------

BENCHMARK TABLE			
NO	STATION	DESCRIPTION	ELEV
38	645+60.89, 32.5' LT	3/8" SPK IN PP W SIDE CTH Z 200'± N OF GOODIN RD	901.57

LEGEND	
	LOG FISH CRIB

CURVE DATA
 DELTA = 6°51'36.00" (RT)
 D = 0°57'17.75"
 T = 359.62
 L = 718.38
 E = 10.77
 R = 6000.00
 DB = N 1°02'56.00" W
 DA = N 5°48'40.00" E
 PC STA 630+65.34
 PC Y = 200329.651
 PC X = 499402.861
 PISTA 634+24.96
 PIY = 200689.209
 PIX = 499396.278
 PT STA 637+83.72
 PT Y = 201046.980
 PT X = 499432.689
 SE = NC

CURVE DATA
 DELTA = 5°14'44.00" (LT)
 D = 0°49'06.64"
 T = 320.66
 L = 640.87
 E = 7.34
 R = 7000.00
 DB = N 5°48'40.00" E
 DA = N 0°33'56.00" E
 PC STA 639+06.18
 PC Y = 201168.814
 PC X = 499445.088
 PISTA 642+26.84
 PIY = 201487.823
 PIX = 499477.554
 PT STA 645+47.05
 PT Y = 201808.464
 PT X = 499480.720
 SE = NC

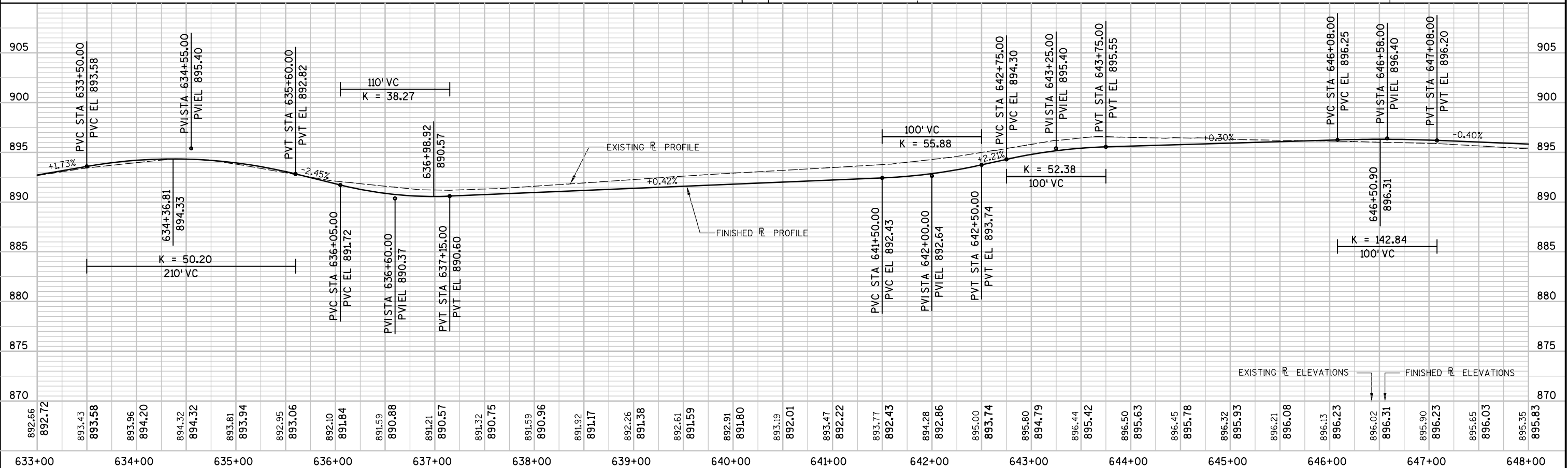
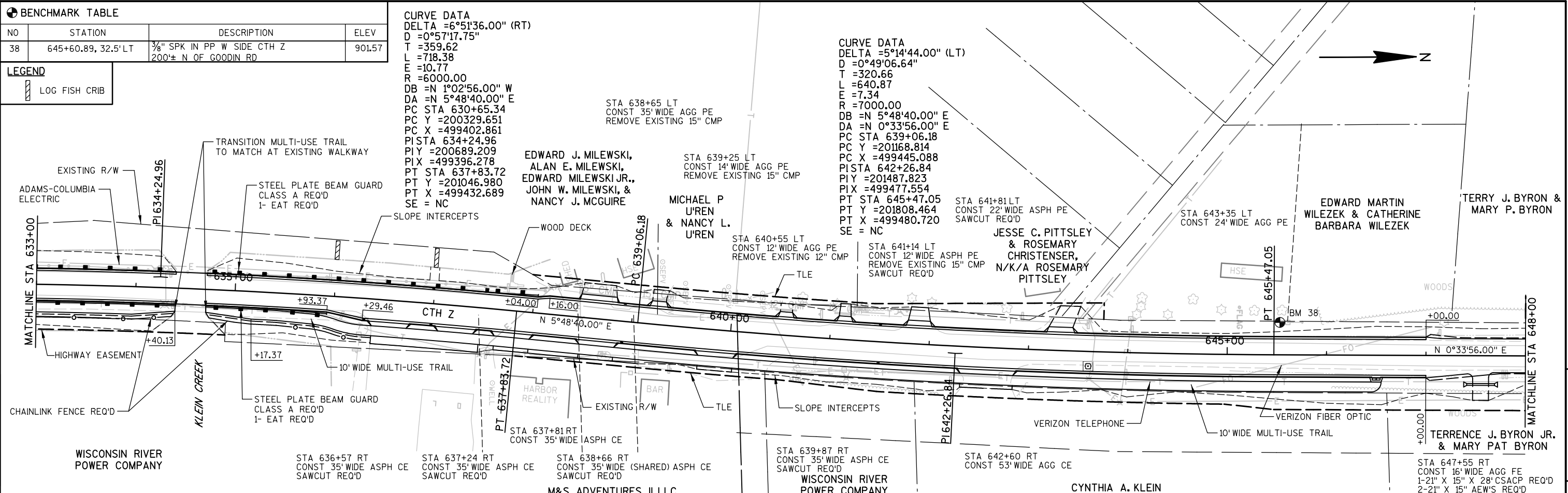

PROJECT NO: 6355-00-74	HWY: CTH Z	COUNTY: ADAMS	PLAN & PROFILE	SCALE, FEET	SHEET	E
------------------------	------------	---------------	----------------	-------------	-------	----------

TERRY J. BYRON &
MARY P. BYRON

STA 648+50 LT
CONST 16' WIDE ASPH PE
1-21" X 15" X 26' CSACP REQ'D
2-21" X 15" STEEL AEW'S REQ'D
SAWCUT REQ'D

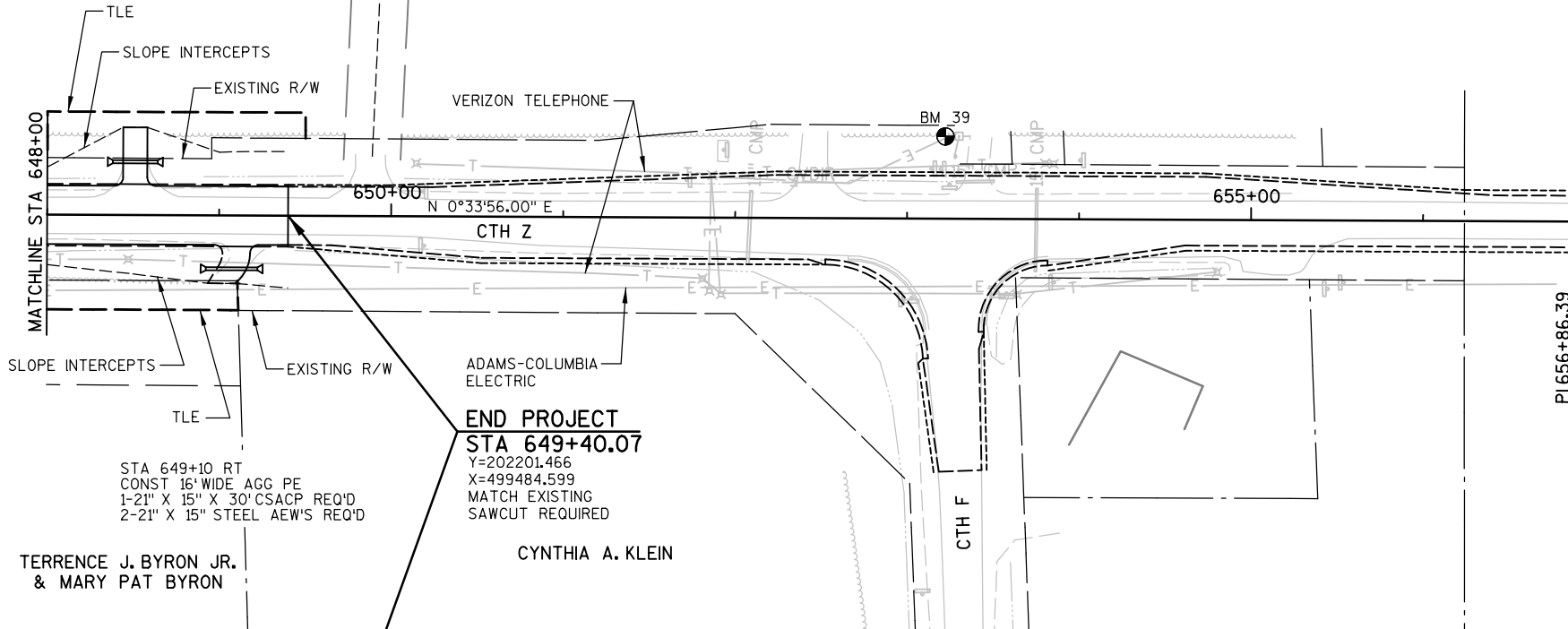

BENCHMARK TABLE			
NO	STATION	DESCRIPTION	ELEV
39	653+30.07, 47.9' LT	3/8" SPK IN PP W SIDE CTH Z & CTH F	893.45

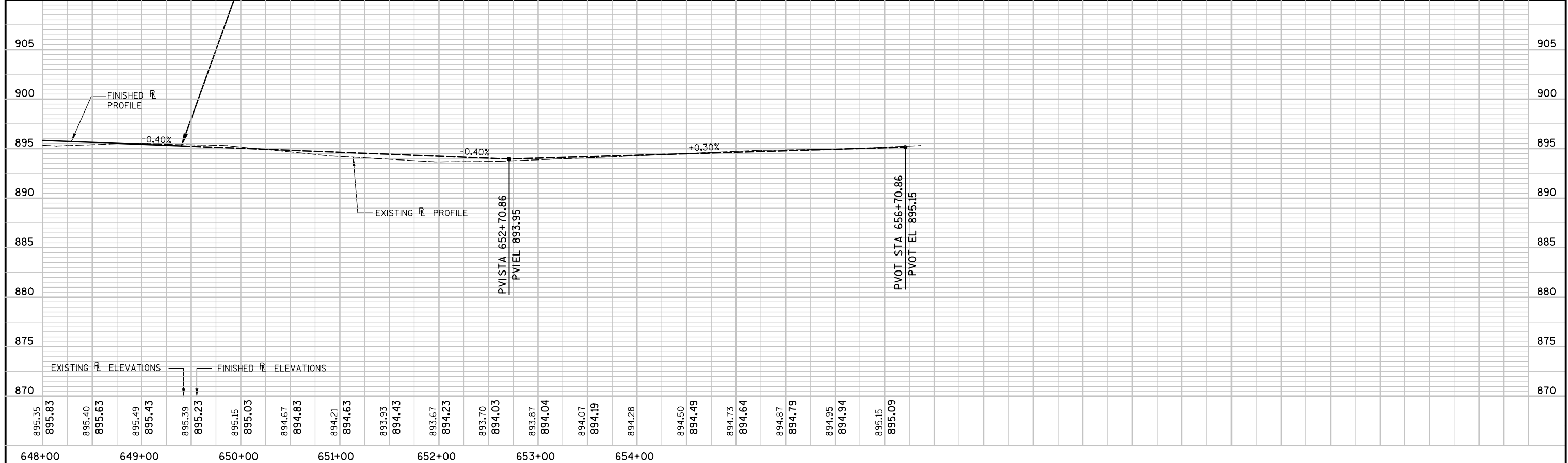

EXISTING R ELEVATIONS	FINISHED R ELEVATIONS
895.35	895.83
895.40	895.63
895.49	895.43
895.39	895.23
895.15	895.03
894.67	894.83
894.21	894.63
893.93	894.43
893.67	894.23
893.70	894.03
893.87	894.04
894.07	894.19
894.28	
894.50	894.49
894.73	894.64
894.87	894.79
894.95	894.94
895.15	895.09

PROJECT NO: 6355-00-74 HWY: CTH Z COUNTY: ADAMS PLAN & PROFILE SCALE, FEET SHEET **E**

CTH Z (includes sideroads) CONT'D			EXP Fact=30%				
STATION	CUT (S.F.)	END AREA FILL (S.F.)	VOLUME		CUMULATIVE VOLUME		MASS HAUL (C.Y.)
			CUT (C.Y.)	FILL (C.Y.)	CUT (C.Y.)	FILL (C.Y.)	
DYKE AVENUE							
600+47	29.1	29.3	177.0	0.0	129714	24890	104824
600+89	19.1	16.8	113.4	94.1	129828	24984	104843
601+42	24.9	18.6	37.5	35.9	129865	25020	104845
601+92	32.1	56.1	43.2	34.7	129908	25055	104853
PARK ENTRANCE							
602+40	52.6	14.3	52.8	69.2	129961	25124	104837
602+85	42.5	45.7	80.0	22.0	130041	25146	104895
603+00	39.1	26.5	75.3	62.6	130116	25209	104908
603+50	20.6	43.7	50.0	50.0	130196	25259	104937
604+00	34.0	34.0	22.7	20.1	130218	25279	104939
604+50	71.9	9.7	55.3	65.0	130273	25344	104930
605+00	172.9	2.1	50.6	71.9	130324	25416	104908
605+45	368.1	0.8	98.1	40.5	130422	25456	104966
605+59	269.7	6.3	226.7	10.9	130649	25467	105182
605+75	267.1	2.5	450.8	2.4	131100	25470	105630
606+00	108.9	3.1	160.6	1.8	131260	25471	105789
606+50	94.8	18.6	163.0	2.7	131423	25474	105949
607+00	90.1	12.1	174.1	2.6	131597	25477	106121
607+05	89.1	13.5	188.6	20.1	131786	25497	106289
607+50	73.2	22.6	171.2	28.4	131957	25525	106432
608+00	71.6	17.5	16.6	2.4	131974	25527	106446
608+50	74.5	14.3	135.3	30.1	132109	25558	106551
609+00	70.6	12.6	134.1	37.1	132243	25595	106648
609+15	68.0	7.1	135.3	29.4	132378	25624	106754
609+50	58.4	12.9	134.4	24.9	132513	25649	106864
610+00	63.6	7.5	38.5	5.5	132551	25654	106897
610+40	77.0	0.2	81.9	13.0	132633	25667	106966
610+70	82.1	6.3	113.0	18.9	132746	25686	107060
611+00	79.0	5.7	104.1	5.7	132850	25692	107158
611+35	87.5	4.4	88.4	3.6	132939	25696	107243
611+50	81.8	0.0	89.5	6.7	133028	25702	107326
612+00	84.0	1.2	107.9	6.5	133136	25709	107427
612+10	83.3	5.7	47.0	1.2	133183	25710	107473
612+80	100.8	0.2	153.5	1.1	133337	25711	107625
613+00	89.4	1.6	31.0	1.3	133368	25712	107655
613+50	87.4	4.8	238.6	7.6	133606	25720	107886
614+00	76.9	6.8	70.4	0.7	133677	25721	107956
614+30	88.5	1.4	163.7	5.9	133840	25727	108114
614+80	89.4	0.7	152.1	10.7	133992	25737	108255
615+00	77.8	8.2	91.9	4.6	134084	25742	108342
615+05	79.2	7.6	164.7	1.9	134249	25744	108505
615+55	99.4	0.0	61.9	3.3	134311	25747	108564
616+00	83.4	6.0	14.5	1.5	134326	25749	108577
616+62	119.0	3.4	165.4	7.0	134491	25756	108735
616+80	97.0	1.9	152.3	5.0	134643	25761	108882
617+00	87.3	5.2	134643	5.0	134643	25761	108882
617+50	86.8	8.3	232.4	10.8	134876	25772	109104
618+00	138.2	11.6	72.0	1.8	134948	25773	109174
618+50	78.1	16.9	68.3	2.6	135016	25776	109240
619+00	64.9	14.2	161.2	12.5	135177	25788	109389
619+50	55.8	22.8	208.3	18.4	135385	25807	109579
619+90	66.1	4.7	200.3	26.4	135586	25833	109752
620+00	66.3	6.0	132.4	28.8	135718	25862	109856
620+50	70.8	3.5	111.8	34.3	135830	25896	109934
620+80	73.9	10.3	90.3	20.4	135920	25917	110003
621+00	69.4	6.6	24.5	2.0	135945	25919	110026
621+36	65.1	17.9	126.9	8.8	136072	25927	110144
DUCK CREEK DRIVE							
622+56	59.0	19.5	80.4	7.7	136152	25935	110217
623+00	59.6	19.3	53.1	6.3	136205	25941	110264
623+20	72.6	18.1	89.7	16.3	136295	25958	110337
623+50	61.5	17.9	335.0	0.0	136630	25958	110672
624+00	66.1	14.8	275.8	83.1	136906	26041	110865
624+50	72.1	11.4	96.6	31.6	137002	26072	110930
625+00	80.3	16.0	49.0	13.9	137051	26086	110965
625+15	94.4	13.9	74.5	20.0	137126	26106	111019
625+50	86.2	14.1	118.1	30.3	137244	26137	111107
626+00	93.8	3.8	128.0	24.3	137372	26161	111211
626+10	107.3	0.0	141.1	25.4	137513	26186	111327
626+85	114.1	0.0	48.5	8.3	137561	26195	111367
627+00	104.7	0.6	117.1	18.1	137678	26213	111466
			166.7	16.6	137845	26229	111616
			37.2	0.7	137882	26230	111652
			307.5	0.0	138190	26230	111960
			60.8	0.2	138251	26230	112020

CTH Z (includes sideroads) CONT'D			EXP Fact=30%				
STATION	CUT (S.F.)	END AREA FILL (S.F.)	VOLUME		CUMULATIVE VOLUME		MASS HAUL (C.Y.)
			CUT (C.Y.)	FILL (C.Y.)	CUT (C.Y.)	FILL (C.Y.)	
627+50	94.0	0.0	184.0	0.6	138435	26231	112204
628+00	86.0	1.2	166.7	1.1	138601	26232	112369
628+50	74.2	0.9	148.3	1.9	138750	26234	112516
628+80	77.9	0.7	84.5	0.9	138834	26235	112599
629+00	70.1	1.5	54.8	0.8	138889	26235	112653
629+50	41.7	24.3	103.5	23.9	138992	26259	112733
630+00	35.7	29.5	71.7	49.8	139064	26309	112755
630+50	33.1	39.0	63.7	63.4	139128	26373	112755
631+00	32.8	40.4	61.0	73.5	139189	26446	112743
631+50	36.2	41.3	63.9	75.6	139253	26522	112731
632+00	46.3	33.8	76.4	69.5	139329	26591	112738
632+50	43.5	37.8	83.1	66.3	139412	26658	112755
633+00	40.0	42.6	77.3	74.4	139490	26732	112758
633+50	36.8	52.2	71.1	87.8	139561	26820	112741
634+00	33.5	73.3	65.1	116.2	139626	26936	112690
635+00	35.9	78.4	128.5	280.9	139754	27217	112537
635+50	51.1	50.6	80.6	119.4	139835	27336	112498
636+00	45.9	46.8	89.8	90.2	139925	27427	112498
636+58	81.2	2.4	136.5	52.8	140061	27479	112582
637+00	75.0	6.3	121.5	6.8	140183	27486	112697
637+24	86.5	2.9	71.8	4.1	140254	27490	112764
637+76	86.1	1.1	166.2	3.9	140421	27494	112927
638+00	97.3	2.2	81.5	1.5	140502	27496	113007
638+65	115.5	0.0	256.1	2.6	140758	27498	113260
639+00	94.3	7.6	136.0	4.9	140894	27503	113391
639+25	113.0	0.2	96.0	3.6	140990	27507	113484
639+50	103.5	8.3	100.2	3.9	141090	27511	113580
640+00	113.0	7.5	200.5	14.6	141291	27525	113766
640+55	116.0	1.1	233.2	8.8	141524	27534	113990
641+00	102.7	8.2	182.3	7.8	141706	27542	114165
641+14	118.5	4.1	57.3	3.2	141764	27545	114219
641+50	109.5	7.6	152.0	7.8	141916	27553	114363
641+89	136.2	5.4	177.5	9.4	142093	27562	114531
642+00	131.5	9.6	54.5	3.1	142148	27565	114583
642+60	115.0	1.4	273.9	12.2	142422	27577	114844
643+00	86.7	8.0	149.4	7.0	142571	27584	114987
643+35	119.9	2.9	133.9	7.1	142705	27591	115113
643+75	93.6	0.2	158.1	2.3	142863	27594	115269
644+00	93.1	0.0	86.4	0.1	142950	27594	115356
644+50	84.2	0.2	164.2	0.2	143114	27594	115520
645+00	58.9	3.7	132.5	3.6	143246	27598	115649
645+50	44.1	14.1	95.4	16.5	143342	27614	115727
646+00	32.9	33.6	71.3	44.2	143413	27658	115755
646+50	25.9	50.7	54.4	78.1	143467	27736	115731
647+00	24.7	47.4	46.9	90.8	143514	27827	115687
647+55	23.0	46.6	48.6	95.7	143563	27923	115640
648+00	20.4	28.9	36.2	62.9	143599	27986	115613
648+50	40.9	29.7	56.8	54.3	143656	28040	115616
649+00	78.3	0.5	110.4	28.0	143766	28068	115698
649+10	86.9	2.1	30.6	0.5	143797	28069	115728
649+40	96.6	0.0	102.2	1.2	143899	28070	115829

9

9

CTH Z (includes sideroads)			EXP Fact=30%					
STATION	CUT (S.F.)	END AREA		VOLUME		CUMULATIVE VOLUME		MASS HAUL (C.Y.)
		FILL (S.F.)	FILL (C.Y.)	CUT (C.Y.)	FILL (C.Y.)	CUT (C.Y.)	FILL (C.Y.)	
100+24	154.7	0.0						
100+64	69.8	16.3	164.4	11.9	164	12	152	
100+85	66.2	10.5	52.1	10.3	216	22	194	
101+00	68.4	26.3	38.6	10.5	255	33	222	
101+50	73.8	7.4	131.7	31.2	387	64	323	
101+70	74.7	6.4	55.0	5.1	442	69	373	
102+00	82.0	0.0	87.1	3.6	529	73	456	
102+31	90.1	0.0	98.8	0.0	628	73	555	
103+00	72.5	0.0	207.8	0.0	835	73	763	
103+50	70.5	0.0	132.4	0.0	968	73	895	
104+00	45.5	0.3	107.4	0.3	1075	73	1002	
104+28	36.3	2.5	42.4	1.5	1118	74	1043	
105+00	16.9	37.7	70.9	53.6	1189	128	1061	
106+00	2.8	14.6	36.4	96.9	1225	225	1000	
107+00	1.5	51.5	7.8	122.4	1233	347	886	
107+19	0.9	131.6	0.8	62.7	1234	410	824	
107+39	47.9	87.0	18.1	81.0	1252	491	761	
107+60	38.1	44.6	34.2	52.4	1286	543	743	
108+00	50.5	22.0	65.6	49.3	1351	593	759	
108+60	81.4	35.8	146.6	64.2	1498	657	841	
109+00	70.8	26.6	112.7	46.2	1611	703	908	
110+00	7.0	40.5	144.1	124.3	1755	827	928	
111+00	9.6	39.9	30.8	148.9	1786	976	809	
111+50	7.1	62.9	15.5	95.2	1801	1071	730	
112+00	21.6	42.2	26.6	97.3	1828	1169	659	
113+00	10.5	22.4	59.4	119.7	1887	1288	599	
113+35	42.9	11.5	34.6	22.0	1922	1310	611	
113+70	31.5	10.3	48.2	14.1	1970	1325	645	
114+00	28.6	7.8	33.4	10.1	2003	1335	669	
115+00	21.0	6.9	91.9	27.3	2095	1362	733	
116+00	20.3	10.3	76.5	31.9	2172	1394	778	
117+00	26.4	9.0	86.5	35.8	2258	1430	828	
117+35	29.2	5.8	36.1	9.6	2294	1439	855	
118+00	18.3	8.3	57.2	17.0	2351	1456	895	
119+00	18.8	8.9	68.7	31.9	2420	1488	932	
120+00	12.6	13.6	58.1	41.7	2478	1530	948	
121+00	16.4	11.9	53.7	47.3	2532	1577	955	
122+00	26.1	7.3	78.7	35.6	2611	1613	998	
123+00	27.8	5.9	99.8	24.5	2710	1637	1073	
124+00	42.3	7.4	129.8	24.7	2840	1662	1178	
125+00	51.3	11.6	173.3	35.3	3014	1697	1316	
126+00	95.2	7.5	271.3	35.4	3285	1733	1552	
127+00	92.4	6.4	347.4	25.7	3632	1759	1874	
128+00	59.3	18.9	280.9	46.8	3913	1805	2108	
129+00	64.7	14.7	229.6	62.3	4143	1868	2275	
129+33	68.4	1.3	81.3	9.8	4224	1877	2347	
130+00	81.2	18.6	185.6	24.6	4410	1902	2508	
131+00	79.6	20.2	297.9	71.9	4708	1974	2734	
132+00	49.6	111.1	239.3	243.1	4947	2217	2730	
132+44	53.6	252.3	84.1	296.1	5031	2513	2518	
132+53	57.5	274.7	18.9	89.8	5050	2603	2447	
132+62	79.0	228.4	22.2	82.0	5072	2685	2387	
133+00	162.3	91.5	169.8	225.1	5242	2910	2332	
134+00	152.9	7.0	583.7	182.4	5826	3092	2733	
135+00	219.0	0.0	688.6	13.0	6514	3105	3409	
136+00	339.6	0.0	1034.3	0.0	7549	3105	4443	
137+00	326.5	0.0	1233.4	0.0	8782	3105	5677	
138+00	279.8	0.0	1122.7	0.0	9905	3105	6799	
139+00	218.5	0.0	922.6	0.0	10827	3105	7722	
140+00	192.5	0.1	760.9	0.2	11588	3106	8483	
141+00	179.2	0.1	688.1	0.4	12276	3106	9171	
142+00	174.9	0.0	655.6	0.2	12932	3106	9826	
142+40	158.7	0.0	247.1	0.0	13179	3106	10073	
142+84	156.9	0.0	257.2	0.0	13436	3106	10330	
143+00	154.4	0.0	92.2	0.0	13528	3106	10422	
143+55	151.0	1.5	311.0	1.5	13840	3108	10732	
144+00	127.3	8.7	231.9	8.5	14071	3116	10955	
144+50	114.0	20.4	223.4	26.9	14295	3143	11152	
145+00	109.1	1.9	206.5	20.6	14501	3164	11338	
146+00	90.7	6.4	370.0	15.2	14871	3179	11693	
147+00	46.6	12.9	254.3	35.6	15126	3214	11911	

CTH Z (includes sideroads) CONT'D			EXP Fact=30%					
STATION	CUT (S.F.)	END AREA		VOLUME		CUMULATIVE VOLUME		MASS HAUL (C.Y.)
		FILL (S.F.)	FILL (C.Y.)	CUT (C.Y.)	FILL (C.Y.)	CUT (C.Y.)	FILL (C.Y.)	
147+70	46.5	8.5	120.7	27.7	15246	3242	12004	
148+00	38.3	16.4	47.1	13.8	15294	3256	12038	
149+00	24.6	13.8	116.5	55.9	15410	3312	12098	
150+00	19.5	16.6	81.7	56.4	15492	3368	12123	
150+55	33.3	19.9	53.8	37.2	15545	3405	12140	
151+00	28.2	21.9	51.2	34.8	15597	3440	12156	
151+80	48.3	5.1	113.3	39.9	15710	3480	12230	
152+00	47.5	22.1	35.5	10.1	15745	3490	12255	
153+00	29.8	25.9	143.0	88.9	15888	3579	12309	
154+00	22.7	29.7	97.1	102.9	15986	3682	12304	
155+00	18.1	19.9	75.6	91.7	16061	3774	12288	
156+00	24.6	11.0	79.1	57.2	16140	3831	12309	
157+00	32.4	11.3	105.6	41.3	16246	3872	12374	
158+00	36.6	7.4	127.8	34.7	16374	3907	12467	
159+00	38.9	4.0	139.8	21.1	16514	3928	12585	
160+00	28.3	6.1	124.4	18.6	16638	3947	12691	
161+00	38.8	12.9	124.3	35.1	16762	3982	12780	
162+00	53.4	15.4	170.7	52.3	16933	4034	12899	
162+85	57.6	11.2	174.7	41.8	17108	4076	13032	
163+00	87.3	8.6	40.3	5.5	17148	4081	13067	
163+27	59.6	18.7	74.3	13.8	17222	4095	13127	
163+70	79.0	1.3	109.6	15.8	17332	4111	13221	
164+00	96.1	0.0	97.3	0.7	17429	4112	13317	
164+30	109.9	0.0	114.4	0.0	17543	4112	13432	
164+45	107.3	0.0	60.3	0.0	17604	4112	13492	
165+00	136.2	0.0	248.0	0.0	17852	4112	13740	
165+70	145.0	0.0	364.5	0.0	18216	4112	14104	
166+00	157.5	0.0	168.0	0.0	18384	4112	14273	
166+84	215.6	0.0	579.6	0.0	18964	4112	14852	
FERN AVENUE			721.0	0.0	19685	4112	15573	
168+19	230.5	0.0	1116.8	0.0	20802	4112	16690	
169+00	156.1	8.2	579.2	12.3	21381	4124	17257	
170+00	72.6	39.6	423.5	88.4	21804	4212	17592	
171+00	41.6	50.7	211.5	167.1	22016	4380	17636	
171+29	61.7	60.4	55.5	59.7	22071	4439	17632	
172+00	56.9	25.1	155.9	112.4	22227	4552	17676	
172+40	72.3	8.7	95.7	25.0	22323	4577	17746	
173+00	70.7	10.9	158.9	21.8	22482	4598	17883	
174+00	61.9	11.8	245.6	42.0	22727	4641	18087	
175+00	46.2	12.0	200.2	44.1	22928	4685	18243	
176+00	36.2	13.9	152.6	48.0	23080	4733	18348	
176+89	35.7	14.7	118.5	47.1	23199	4780	18419	
177+00	36.8	11.6	14.8	5.4	23213	4785	18428	
177+30	51.8	6.8	49.2	10.2	23263	4795	18467	
178+00	41.1	11.8	120.4	24.1	23383	4819	18564	
179+00	46.4	9.4	162.0	39.3	23545	4859	18686	
179+42	61.7	5.3	84.1	11.4	23629	4870	18759	
180+00	50.8	6.0	120.8	12.1	23750	4882	18868	
181+00	17.5	17.6	126.5	43.7	23877	4926	18951	
181+40	21.4	8.5	28.8	19.3	23905	4945	18960	
182+00	18.3	18.9	44.1	30.4	23949	4976	18974	
182+75	31.2	7.8	68.8	37.1	24018	5013	19005	
183+00	26.8	13.1	26.9	9.7	24045	5022	19023	
184+00	24.0	13.8	94.1	49.8	24139	5072	19067	
185+00	20.9	14.8	83.1	53.0	24222	5125	19097	
186+00	24.5	16.2	84.1	57.4	24306	5183	19124	
187+00	25.4	11.9	92.4	52.0	24399	5235	19164	
188+00	51.8	0.0	143.0	22.0	24542	5257	19285	
188+05	56.0	0.0	10.0	0.0	24552	5257	19295	
189+00	56.8	3.1	198.4	5.5	24750	5262	19488	
189+10	63.6	3.3	22.3	1.2	24772	5263	19509	
190+00	36.2	9.4	166.3	21.2	24939	5285	19654	
190+68	14.3	36.8	63.5	58.1	25002	5343	19660	
191+00	14.8	27.2	17.3	38.0	25020	5381	19639	
191+93	17.7	35.2	55.9	107.4	25075	5488	19587	
192+00	18.0	30.6	4.7	8.7	25080	5497	19583	
193+00	31.4	17.3	91.5	88.7	25172	5585	19586	
194+00	34.8	15.1	122.6	60.0	25294	5645	19649	
194+75	47.7	9.4	114.6	34.0	25409	5679	19729	
195+00	36.1	14.0	38.8	10.8	25448	5690	19757	
196+00	34.9	15.5	131.5	54.6	25579	5745	19834	

CTH Z (includes sideroads) CONT'D

EXP Fact=30%

STATION	END AREA		VOLUME CUT (C.Y.)	FILL (C.Y.)	CUMULATIVE VOLUME		MASS HAUL (C.Y.)
	CUT (S.F.)	FILL (S.F.)			CUT (C.Y.)	FILL (C.Y.)	
197+00	23.1	8.2	107.4	43.9	25687	5789	19898
198+00	30.4	4.6	99.1	23.7	25786	5812	19973
198+72	44.0	1.3	99.2	7.9	25885	5820	20064
199+00	45.3	1.4	46.3	1.4	25931	5822	20109
199+10	51.1	1.3	17.9	0.5	25949	5822	20127
200+00	43.1	2.0	157.0	5.5	26106	5828	20278
201+00	56.0	1.2	183.5	5.9	26289	5834	20456
202+00	50.3	1.0	196.9	4.1	26486	5838	20649
203+00	19.1	11.8	128.5	23.7	26615	5861	20753
204+00	21.5	5.3	75.2	31.7	26690	5893	20797
205+00	42.6	4.5	118.7	18.1	26809	5911	20897
205+50	56.9	4.4	92.1	8.2	26901	5919	20981
206+00	63.5	4.3	111.5	8.1	27012	5928	21085
207+00	65.0	1.1	238.0	10.0	27250	5938	21313
208+00	46.8	5.1	207.0	11.5	27457	5949	21508
209+00	29.4	14.7	141.1	36.7	27598	5986	21613
210+00	32.7	10.6	115.0	46.9	27713	6033	21681
210+10	35.8	10.5	12.7	3.9	27726	6036	21690
211+00	39.5	10.0	125.5	34.2	27852	6071	21781
212+00	46.1	11.0	158.5	38.9	28010	6109	21901
213+00	73.3	10.0	221.1	38.9	28231	6148	22083
214+00	99.5	9.1	320.0	35.4	28551	6184	22367
FAWN AVENUE			318.0	146.0	28869	6330	22539
215+35	62.2	22.2	404.8	78.4	29274	6408	22866
216+00	7.3	71.7	83.4	112.7	29358	6521	22837
216+49	5.5	138.3	11.6	190.6	29369	6711	22658
217+00	4.4	66.8	9.4	193.7	29379	6905	22473
217+31	4.4	66.8	5.0	75.5	29383	6981	22403
STRUCTURE B-1-26							
217+79	8.1	63.5					
218+00	8.1	63.5	6.3	49.4	29390	7030	22360
218+60	0.0	103.4	9.0	185.4	29399	7215	22183
219+00	0.0	80.2	0.0	136.0	29399	7351	22047
219+75	0.0	34.2	0.0	158.9	29399	7510	21889
220+00	0.0	48.0	0.0	38.1	29399	7548	21850
221+00	2.1	23.1	3.9	131.7	29403	7680	21723
222+00	23.7	6.5	47.8	54.8	29450	7735	21716
222+90	21.5	2.7	75.3	15.3	29526	7750	21776
223+00	21.9	5.4	8.0	1.5	29534	7752	21782
224+00	22.3	20.3	81.9	47.6	29616	7799	21816
224+87	23.2	24.3	73.3	71.9	29689	7871	21818
225+00	22.2	24.5	10.9	11.7	29700	7883	21817
226+00	19.0	21.5	76.3	85.2	29776	7968	21808
227+00	18.3	21.0	69.1	78.7	29845	8047	21799
228+00	23.9	13.8	78.1	64.4	29923	8111	21812
228+20	34.8	3.2	21.7	6.3	29945	8117	21828
229+00	41.8	4.5	113.5	11.4	30059	8129	21930
230+00	26.6	17.4	126.7	40.6	30185	8169	22016
231+00	45.9	12.2	134.3	54.8	30320	8224	22095
232+00	38.8	11.1	156.9	43.1	30476	8267	22209
232+60	30.7	11.3	77.2	24.9	30554	8292	22261
233+00	35.5	13.7	49.0	18.5	30603	8311	22292
233+30	37.0	9.9	40.3	13.1	30643	8324	22319
234+00	71.7	5.3	140.9	19.7	30784	8344	22440
235+00	165.3	0.2	438.9	10.2	31223	8354	22869
236+00	147.5	1.2	579.3	2.6	31802	8356	23446
236+15	131.1	13.7	77.4	4.1	31879	8361	23519
237+00	85.1	25.4	340.3	61.5	32220	8422	23798
237+29	77.5	42.3	87.9	36.6	32308	8459	23849
238+00	18.9	113.5	126.4	204.3	32434	8663	23771
238+08	18.9	113.5	5.5	33.0	32440	8696	23744
STRUCTURE B-1-27							
238+34	15.1	86.3					
238+60	15.1	86.3	14.3	82.0	32454	8778	23676
239+00	38.2	99.9	39.5	137.9	32493	8916	23578
239+13	39.1	104.8	18.6	49.3	32512	8965	23547
240+00	42.3	74.5	131.1	288.9	32643	9254	23389
241+00	57.1	30.4	184.1	194.3	32827	9448	23379
242+00	61.2	30.7	219.1	113.1	33046	9561	23485
243+00	52.1	24.7	209.8	102.6	33256	9664	23592
243+60	42.9	19.6	105.6	49.2	33362	9713	23648

CTH Z (includes sideroads) CONT'D

EXP Fact=30%

STATION	END AREA		VOLUME CUT (C.Y.)	FILL (C.Y.)	CUMULATIVE VOLUME		MASS HAUL (C.Y.)
	CUT (S.F.)	FILL (S.F.)			CUT (C.Y.)	FILL (C.Y.)	
244+00	31.4	29.4	55.0	36.3	33417	9750	23667
245+00	4.7	43.2	66.9	134.4	33484	9884	23600
246+00	5.9	31.2	19.6	137.8	33503	10022	23481
246+35	26.8	9.1	21.2	26.1	33524	10048	23476
247+00	30.4	15.8	68.9	30.0	33593	10078	23515
248+00	47.4	8.3	144.1	44.6	33737	10122	23615
249+00	42.6	14.5	166.7	42.2	33904	10165	23739
250+00	35.1	22.3	143.9	68.1	34048	10233	23815
251+00	22.9	29.2	107.4	95.4	34155	10328	23827
252+00	23.8	19.7	86.5	90.6	34242	10419	23823
253+00	42.7	6.9	123.1	49.3	34365	10468	23897
254+00	71.0	6.8	210.6	25.4	34575	10493	24082
255+00	113.0	5.7	340.7	23.1	34916	10517	24400
255+93	57.6	19.7	293.8	43.7	35210	10560	24650
256+00	57.5	20.8	14.9	5.3	35225	10566	24659
257+00	7.9	29.1	121.1	92.4	35346	10658	24688
258+00	14.2	34.7	40.9	118.1	35387	10776	24611
259+00	40.8	25.5	101.9	111.5	35489	10888	24601
259+55	73.7	0.0	116.6	26.0	35605	10914	24692
259+60	74.7	0.9	13.7	0.1	35619	10914	24706
260+00	66.6	6.5	104.7	5.5	35724	10919	24805
261+00	5.3	41.8	133.1	89.4	35857	11009	24848
262+00	0.9	43.2	11.5	157.4	35868	11166	24702
263+00	31.5	33.0	60.0	141.1	35928	11307	24621
263+60	78.4	10.7	122.1	48.6	36051	11356	24695
264+00	99.2	9.5	131.6	15.0	36182	11371	24812
265+00	110.3	13.0	388.0	41.7	36570	11412	25158
266+00	95.1	10.0	380.4	42.6	36950	11455	25496
267+00	102.0	7.9	365.0	33.1	37315	11488	25827
268+00	92.0	7.3	359.3	28.1	37675	11516	26159
269+00	72.5	7.7	304.6	27.8	37979	11544	26435
270+00	56.3	11.3	238.5	35.2	38218	11579	26639
271+00	56.2	3.6	208.3	27.6	38426	11607	26819
272+00	60.8	1.2	216.7	8.9	38643	11616	27027
272+30	68.8	1.1	72.0	1.3	38715	11617	27098
273+00	51.7	0.9	156.2	2.6	38871	11619	27252
273+30	56.3	0.8	60.0	0.9	38931	11620	27311
273+55	58.9	0.0	53.3	0.4	38984	11621	27364
273+65	50.1	0.9	20.2	0.2	39005	11621	27384
274+00	56.0	2.9	68.8	2.5	39073	11623	27450
275+00	46.5	9.4	189.8	22.8	39263	11646	27617
276+00	73.6	5.2	222.4	27.0	39486	11673	27812
276+97	85.8	3.6	286.6	15.8	39772	11689	28083
CTH H			457.0	8.0	40229	11697	28532
278+34	158.7	0.5	618.9	10.4	40848	11707	29141
278+50	129.7	0.2	86.5	0.2	40935	11708	29227
279+00	121.6	0.8	232.7	0.9	41167	11709	29459
280+00	99.5	13.3	409.4	26.1	41577	11735	29842
281+00	102.2	4.1	373.5	32.2	41950	11767	30183
282+00	103.8	4.4	381.5	15.7	42332	11783	30549
283+00	103.5	5.0	383.9	17.4	42716	11800	30916
283+50	101.2	5.6	189.5	9.8	42905	11810	31095
284+00	103.6	7.3	189.6	11.9	43095	11822	31273
285+00	113.2	11.3	401.5	34.4	43496	11856	31640
286+00	127.9	12.2	446.5	43.5	43943	11900	32043
287+00	136.0	18.5	488.7	56.9	44431	11957	32475
288+00	137.1	22.1	505.7	75.2	44937	12032	32905
289+00	167.7	7.7	564.4	55.2	45502	12087	33415
289+10	162.1	6.3	61.1	2.6	45563	12090	33473
289+75	189.3	10.7	423.0	20.5	45986	12110	33876
290+00	142.2	6.9	153.5	8.1	46139	12118	34021
291+00	149.0	7.6	539.3	26.9	46678	12145	34533
292+00	123.9	6.1	505.4	25.4	47184	12170	35013
293+00	128.2	6.1	466.9	22.6	47651	12193	35458
294+00	137.0	20.1	491.1	48.5	48142	12242	35900
295+00	105.8	30.9	449.6	94.4	48591	12336	36255
295+70	97.5	16.8	263.5	61.8	48855	12398	36457
296+00	97.2	10.9	108.2	15.4	48963	12413	36550
296+50	96.6	7.9	179.4	17.4	49143	12431	36712
297+00	96.0	3.6	178.3	10.6	49321	12441	36880
297+95	110.6	0.0	363.5	6.3	49684	12448	37237

9

9

CTH Z (includes sideroads) CONT'D

EXP Fact=30%

STATION	END AREA		VOLUME		CUMULATIVE VOLUME		MASS HAUL (C.Y.)
	CUT (S.F.)	FILL (S.F.)	CUT (C.Y.)	FILL (C.Y.)	CUT (C.Y.)	FILL (C.Y.)	
298+00	112.0	0.0	20.6	0.0	49705	12448	37257
299+00	124.3	0.9	437.6	1.7	50143	12449	37693
300+00	129.6	2.0	470.2	5.4	50613	12455	38158
301+00	142.5	4.5	503.9	12.0	51117	12467	38650
302+00	133.6	9.8	511.3	26.5	51628	12493	39135
303+00	114.8	21.0	460.0	57.0	52088	12550	39538
304+00	74.0	25.8	349.6	86.7	52438	12637	39801
305+00	102.3	17.0	326.5	79.3	52764	12716	40048
306+00	99.3	8.2	373.3	46.7	53137	12763	40375
307+00	56.6	10.1	288.7	33.9	53426	12797	40629
308+00	39.0	8.7	177.0	34.8	53603	12831	40772
309+00	53.4	3.3	171.1	22.2	53774	12854	40921
310+00	71.5	2.4	231.3	10.6	54006	12864	41141
310+13	73.9	1.9	35.4	1.0	54041	12865	41176
	EVERGREEN AVENUE		262.0	1.0	54303	12866	41437
311+08	95.0	0.0	296.7	3.3	54600	12870	41730
311+49	92.4	0.0	140.9	0.0	54741	12870	41871
312+00	97.9	0.0	181.1	0.0	54922	12870	42052
312+10	102.2	0.0	37.1	0.0	54959	12870	42089
313+00	112.3	0.8	357.5	1.3	55316	12871	42445
314+00	127.5	0.0	444.1	1.5	55760	12872	42888
315+00	141.7	0.0	498.5	0.0	56259	12872	43386
316+00	130.5	1.2	504.1	2.2	56763	12875	43888
	QUINCY SS OUTFALL		51.0	19.0	56814	12894	43920
316+31	129.6	1.2	148.3	1.4	56962	12895	44067
316+70	98.1	0.6	165.4	1.3	57128	12896	44231
316+90	86.3	2.4	68.3	1.1	57196	12897	44298
	SOUTH EMBER LANE		99.0	1.0	57295	12898	44396
317+84	53.2	2.9	242.8	9.2	57538	12908	44630
318+00	55.1	2.9	32.1	1.7	57570	12909	44660
318+30	66.4	0.0	67.5	1.6	57637	12911	44726
318+65	74.7	0.0	91.5	0.0	57729	12911	44818
318+70	72.5	0.0	13.6	0.0	57742	12911	44831
319+00	63.7	2.1	75.7	1.2	57818	12912	44906
319+40	76.2	0.0	103.7	1.6	57922	12914	45008
320+00	66.6	0.6	158.7	0.7	58080	12914	45166
320+15	73.0	0.0	38.8	0.2	58119	12915	45205
320+40	81.3	0.6	71.4	0.3	58191	12915	45276
321+00	96.4	0.0	197.4	0.7	58388	12915	45472
321+05	96.4	0.0	17.9	0.0	58406	12915	45490
322+00	90.7	0.3	329.2	0.5	58735	12916	45819
322+10	86.0	0.2	32.7	0.1	58768	12916	45852
323+00	94.2	0.0	300.3	0.3	59068	12916	46152
323+25	125.6	0.0	101.8	0.0	59170	12916	46253
323+65	120.1	0.0	182.0	0.0	59352	12916	46435
324+00	107.9	0.0	147.8	0.0	59500	12916	46583
325+00	95.3	0.0	376.3	0.0	59876	12916	46959
325+75	102.5	0.0	274.7	0.0	60151	12916	47234
326+00	85.1	0.0	86.9	0.0	60237	12916	47321
326+05	88.6	0.0	16.1	0.0	60254	12916	47337
327+00	79.1	0.4	295.0	0.7	60549	12917	47631
328+00	181.6	0.0	482.8	0.7	61031	12918	48113
329+00	150.6	0.0	615.2	0.0	61647	12918	48729
	KINNAS DITCH		107.0	0.0	61754	12918	48836
329+35	187.7	0.1	219.3	0.1	61973	12918	49055
330+00	174.3	0.0	435.7	0.1	62409	12918	49490
330+10	169.7	0.0	63.7	0.0	62472	12918	49554
331+00	156.6	0.0	543.8	0.0	63016	12918	50098
331+30	151.2	0.0	171.0	0.0	63187	12918	50269
332+00	153.9	0.0	395.5	0.0	63583	12918	50664
332+75	202.4	0.0	494.9	0.0	64077	12918	51159
333+00	185.2	0.0	179.4	0.0	64257	12918	51339
334+00	141.3	0.0	604.6	0.0	64861	12918	51943
334+05	137.6	0.0	25.8	0.0	64887	12918	51969
335+00	93.8	0.1	407.1	0.2	65294	12918	52376
336+00	49.1	3.3	264.6	6.3	65559	12925	52634
336+15	56.4	1.7	29.3	1.4	65588	12926	52662
337+00	50.9	4.2	168.9	9.3	65757	12935	52822
338+00	59.7	3.2	204.8	13.7	65962	12949	53013
338+20	64.7	1.9	46.1	1.9	66008	12951	53057
339+00	58.8	1.6	183.0	5.2	66191	12956	53235

CTH Z (includes sideroads) CONT'D

EXP Fact=30%

STATION	END AREA		VOLUME		CUMULATIVE VOLUME		MASS HAUL (C.Y.)
	CUT (S.F.)	FILL (S.F.)	CUT (C.Y.)	FILL (C.Y.)	CUT (C.Y.)	FILL (C.Y.)	
339+80	51.2	4.5	163.0	9.0	66354	12965	53389
340+00	51.7	4.1	38.1	3.2	66392	12968	53424
340+40	63.4	0.9	85.3	3.7	66477	12972	53506
341+00	68.0	2.2	146.0	3.4	66623	12975	53648
341+65	68.2	0.7	163.9	3.5	66787	12979	53809
342+00	73.4	4.1	91.8	3.1	66879	12982	53897
342+75	93.1	0.5	231.3	6.4	67110	12988	54122
343+00	98.4	0.2	88.7	0.3	67199	12989	54210
344+00	91.3	1.4	351.3	3.0	67550	12992	54559
344+20	90.4	1.9	67.3	1.2	67618	12993	54625
345+00	89.4	3.4	266.4	7.9	67884	13001	54883
345+15	68.2	5.2	43.8	2.4	67928	13003	54925
346+00	55.9	6.6	195.3	18.6	68123	13022	55101
347+00	61.6	1.4	217.6	14.8	68341	13037	55304
347+30	67.1	0.6	71.5	1.1	68412	13038	55375
348+00	85.7	0.3	198.1	1.2	68610	13039	55572
348+05	88.2	0.2	16.1	0.0	68626	13039	55588
348+75	104.4	0.1	249.7	0.4	68876	13039	55837
349+00	114.7	0.0	101.4	0.0	68978	13039	55938
350+00	103.8	0.1	404.6	0.2	69382	13039	56343
351+00	108.8	0.0	393.7	0.2	69776	13040	56736
352+00	72.1	0.9	335.0	1.7	70111	13041	57070
353+00	50.8	5.0	227.6	10.9	70338	13052	57286
354+00	34.5	8.7	158.0	25.4	70496	13078	57419
354+50	27.7	16.4	57.6	23.2	70554	13101	57453
355+00	29.8	17.4	53.2	31.3	70607	13132	57475
355+65	43.5	1.5	88.2	22.8	70695	13155	57541
356+00	56.4	4.1	64.8	3.6	70760	13159	57602
357+00	75.2	1.8	243.7	10.9	71004	13169	57834
358+00	62.6	0.0	255.2	3.3	71259	13173	58086
358+05	62.1	0.0	11.5	0.0	71271	13173	58098
359+00	54.8	2.3	205.7	4.0	71476	13177	58299
360+00	55.4	2.5	204.1	8.9	71680	13186	58495
360+60	66.7	2.5	135.7	5.6	71816	13191	58625
361+00	66.3	1.2	98.5	2.7	71915	13194	58721
361+30	60.3	0.7	70.3	1.1	71985	13195	58790
361+45	65.1	0.0	34.8	0.2	72020	13195	58824
362+00	52.9	1.0	120.2	1.0	72140	13196	58944
363+00	56.9	0.1	203.3	2.0	72343	13198	59145
363+75	85.2	0.0	197.4	0.1	72541	13198	59342
364+00	84.5	0.0	78.6	0.0	72619	13198	59421
365+00	71.4	0.1	288.7	0.2	72908	13199	59709
366+00	127.2	0.0	367.8	0.2	73276	13199	60077
367+00	122.2	0.0	461.9	0.0	73738	13199	60539
367+25	133.8	0.1	118.5	0.0	73856	13199	60657
368+00	80.0	0.5	296.9	0.8	74153	13200	60953
369+00	21.7	25.4	188.3	48.0	74341	13248	61094
	EMBER AVENUE		88.0	398.0	74429	13646	60784
370+34	6.1	100.8	69.2	314.1	74499	13960	60539
371+00	25.2	77.0	38.0	216.0	74537	14176	60361
371+75	39.9	25.9	90.4	142.9	74627	14319	60308
372+00	43.5	18.3	38.6	20.5	74666	14339	60326
372+50	64.4	9.2	99.9	25.5	74765	14365	60401
372+95	61.1	11.3	104.6	17.1	74870	14382	60488
373+00	61.2	11.1	11.3	2.1	74881	14384	60498
374+00	51.8	11.0	209.3	40.9	75091	14425	60666
374+25	47.6	8.1	46.0	8.8	75137	14434	60703
375+00	41.6	4.5	123.9	17.5	75261	14451	60810
375+65	46.2	4.3	105.7	10.6	75366	14462	60905
376+00	30.9	10.8	50.0	9.8	75416	14471	60945
377+00	31.4	5.8	115.4	30.7	75532	14502	61029
377+20	39.3	3.9	26.2	3.6	75558	14506	61052
378+00	41.4	2.9	119.6	10.1	75677	14516	61161
378+33	38.4	2.2	48.8	3.1	75726	14519	61207
378+70	50.9	1.6	61.2	2.6	75787	14522	61266
379+00	35.2	3.0	47.8	2.6	75835	14524	61311
380+00	27.9	3.9	116.9	12.8	75952	14537	61415
380+30	33.9	1.5	34.3	3.0	75986	14540	61446
381+00	33.6	4.5	87.5	7.8	76074	14548	61526
382+00	29.2	6.8	116.3	20.9	76190	14569	61622
383+00	33.8	2.8	116.7	17.8	76307	14586	61720

9

9

CTH Z (includes sideroads) CONT'D

EXP Fact=30%

STATION	END AREA		VOLUME		CUMULATIVE VOLUME		MASS HAUL (C.Y.)
	CUT (S.F.)	FILL (S.F.)	CUT (C.Y.)	FILL (C.Y.)	CUT (C.Y.)	FILL (C.Y.)	
384+00	33.4	3.1	124.4	10.9	76431	14597	61834
385+00	28.9	4.1	115.4	13.3	76547	14611	61936
386+00	27.7	3.9	104.8	14.8	76651	14625	62026
387+00	26.2	4.1	99.8	14.8	76751	14640	62111
388+00	31.7	0.1	107.2	7.8	76858	14648	62210
389+00	30.2	0.2	114.6	0.6	76973	14649	62324
390+00	29.2	0.1	110.0	0.6	77083	14649	62434
391+00	32.5	3.2	114.3	6.1	77197	14655	62542
392+00	32.4	2.3	120.2	10.2	77317	14665	62652
393+00	30.3	0.4	116.1	5.0	77434	14670	62763
394+00	36.0	3.6	122.8	7.4	77556	14678	62879
395+00	40.6	2.8	141.9	11.9	77698	14690	63009
396+00	37.6	2.4	144.8	9.6	77843	14699	63144
397+00	34.6	2.2	133.7	8.5	77977	14708	63269
398+00	31.9	3.0	123.1	9.6	78100	14717	63382
399+00	22.4	5.8	100.6	16.3	78200	14734	63467
400+00	56.6	2.5	146.3	15.4	78347	14749	63598
400+28	76.5	2.0	68.3	2.3	78415	14751	63664
ELK DRIVE EAST			352.0	9.0	78767	14760	64007
401+63	155.9	0.1	581.9	5.3	79349	14766	64583
402+00	131.0	0.0	197.1	0.1	79546	14766	64780
403+00	8.7	45.3	258.7	83.9	79805	14850	64955
403+28	2.2	77.3	14913	63.6	79810	14913	64897
404+00	27.6	27.8	39.7	140.1	79850	15053	64797
404+76	55.1	17.5	116.5	63.8	79967	15117	64849
ELK DRIVE WEST			134.0	1.0	80101	15118	64982
406+00	57.2	17.1	257.7	79.4	80358	15198	65161
407+00	87.5	15.8	268.0	60.9	80626	15259	65368
408+00	92.5	13.5	333.3	54.3	80960	15313	65647
408+50	103.3	19.8	181.3	30.8	81141	15344	65797
409+00	113.0	5.9	200.3	23.8	81341	15367	65974
409+25	119.1	9.6	107.5	7.2	81449	15375	66074
409+50	92.5	23.6	98.0	15.4	81547	15390	66157
410+00	80.6	9.7	160.3	30.9	81707	15421	66286
411+00	48.4	12.3	238.9	40.7	81946	15462	66484
412+00	36.1	12.5	156.6	45.9	82102	15507	66595
413+00	69.2	4.6	195.1	31.7	82297	15539	66758
413+50	65.1	10.2	124.4	13.7	82422	15553	66869
414+00	70.3	3.7	125.4	12.9	82547	15566	66981
415+00	103.8	0.2	322.4	7.3	82870	15573	67297
415+35	120.7	0.0	145.5	0.1	83015	15573	67442
416+00	151.4	0.0	327.5	0.0	83343	15573	67769
417+00	101.4	0.0	468.1	0.0	83811	15573	68238
418+00	56.2	0.0	291.9	0.0	84103	15573	68529
419+00	0.4	7.5	104.8	13.9	84207	15587	68620
420+00	1.9	2.9	4.3	19.3	84212	15606	68605
421+00	2.5	2.9	8.1	10.7	84220	15617	68603
421+32	1.6	3.2	2.4	3.6	84222	15621	68602
422+00	0.5	5.5	2.6	11.0	84225	15632	68593
423+00	1.8	6.1	4.3	21.5	84229	15653	68576
424+00	0.0	10.5	3.3	30.7	84233	15684	68549
424+16	0.0	10.2	0.0	6.1	84233	15690	68542
425+00	0.0	10.7	0.0	32.5	84233	15723	68510
426+00	1.5	6.6	2.8	32.0	84235	15755	68481
427+00	2.3	9.1	7.0	29.1	84242	15784	68459
427+80	0.5	6.2	4.1	22.6	84246	15806	68440
19TH DRIVE			28.2	6.4	84275	15813	68462
429+10	3.1	9.0	8.7	36.7	84283	15849	68434
430+00	1.9	6.5	8.3	25.8	84292	15875	68417
431+00	4.3	4.1	11.5	19.6	84303	15895	68408
431+91	42.5	6.1	79.0	17.2	84382	15912	68470
ELK AVENUE LT & RT			562.0	0.4	84944	15912	69032
433+40	77.4	4.4	330.8	29.0	85275	15941	69334
434+00	68.5	1.9	161.8	7.0	85437	15948	69488
434+15	76.7	8.1	40.3	2.8	85477	15951	69526
435+00	68.0	7.1	227.8	23.9	85705	15975	69730
436+00	60.5	9.9	238.0	31.5	85943	16007	69936
437+00	26.2	29.3	160.6	72.6	86103	16079	70024
438+00	11.6	32.4	70.1	114.3	86173	16193	69980
439+00	5.4	39.9	31.6	133.9	86205	16327	69878
439+65	3.9	35.0	11.2	90.2	86216	16417	69799
440+00	4.2	39.5	5.3	48.3	86221	16466	69756

CTH Z (includes sideroads) CONT'D

EXP Fact=30%

STATION	END AREA		VOLUME		CUMULATIVE VOLUME		MASS HAUL (C.Y.)
	CUT (S.F.)	FILL (S.F.)	CUT (C.Y.)	FILL (C.Y.)	CUT (C.Y.)	FILL (C.Y.)	
441+00	18.3	23.5	41.7	116.7	86263	16582	69681
442+00	49.6	12.2	125.7	66.1	86389	16649	69740
443+00	61.3	6.5	205.4	34.6	86594	16683	69911
444+00	39.5	17.7	186.7	44.8	86781	16728	70053
445+00	32.5	23.8	133.3	76.9	86914	16805	70109
446+00	40.3	17.3	134.8	76.1	87049	16881	70168
447+00	45.6	17.3	159.0	64.1	87208	16945	70263
448+00	57.4	16.5	190.6	62.6	87399	17008	70391
449+00	69.8	14.1	235.4	56.7	87634	17064	70570
450+00	87.1	13.4	290.5	50.9	87925	17115	70809
451+00	94.2	15.5	335.9	53.5	88260	17169	71092
452+00	115.9	17.3	389.1	60.7	88650	17229	71420
453+00	166.5	14.1	523.0	58.1	89173	17288	71885
454+00	194.8	10.9	669.0	46.3	89842	17334	72508
455+00	181.0	11.8	695.8	42.0	90537	17376	73161
456+00	89.7	26.4	501.2	70.7	91039	17447	73592
457+00	79.6	15.0	313.5	76.7	91352	17523	73829
458+00	58.3	40.6	255.3	103.0	91607	17626	73981
458+24	46.8	55.0	46.7	42.5	91654	17669	73985
459+10	77.2	25.3	198.4	128.5	91852	17797	74055
EDGEWOOD DRIVE			124.0	6.0	91976	17803	74173
460+05	175.7	0.0	444.9	44.5	92421	17848	74574
460+33	239.1	0.0	215.1	0.0	92636	17848	74789
460+60	226.8	1.8	229.4	0.9	92866	17849	75017
461+00	174.9	1.1	297.5	2.1	93163	17851	75313
462+00	196.3	1.8	687.3	5.4	93851	17856	75995
463+00	174.8	4.3	687.1	11.3	94538	17867	76670
464+00	91.5	10.1	493.1	26.7	95031	17894	77137
465+00	74.2	18.6	306.8	53.1	95338	17947	77390
466+00	84.5	6.9	293.9	47.2	95632	17994	77637
466+15	87.0	21.6	47.6	7.9	95679	18002	77677
466+75	85.1	16.4	191.2	42.2	95870	18045	77826
467+00	79.0	6.9	76.0	10.8	95946	18055	77891
467+10	82.4	15.5	29.9	4.1	95976	18060	77917
468+00	64.2	18.8	244.3	57.2	96221	18117	78104
468+75	68.5	29.7	184.3	67.4	96405	18184	78221
469+00	70.3	15.0	64.3	20.7	96469	18205	78264
470+00	58.7	15.1	239.0	55.7	96708	18261	78448
471+00	47.3	20.6	196.4	66.1	96905	18327	78578
472+00	44.5	22.9	170.0	80.6	97075	18407	78667
473+00	41.5	20.0	159.2	79.4	97234	18487	78747
474+00	43.0	16.5	156.6	67.6	97390	18554	78836
475+00	44.4	14.5	161.8	57.4	97552	18612	78941
476+00	36.9	13.1	150.5	51.1	97703	18663	79040
477+00	27.1	15.8	118.6	53.5	97821	18716	79105
477+85	38.8	21.5	103.8	58.7	97925	18775	79150
478+00	44.5	5.0	23.1	7.4	97948	18782	79166
479+00	66.0	1.9	204.8	12.8	98153	18795	79358
479+05	660.5	8.0	67.3	0.9	98220	18796	79424
479+90	50.8	11.5	1119.6	30.7	99340	18827	80513
480+00	45.9	3.6	17.9	2.8	99358	18830	80528
481+00	34.3	12.7	148.6	30.2	99506	18860	80646
482+00	36.0	15.4	130.3	52.0	99636	18912	80725
482+90	43.3	15.1	132.2	50.8	99769	18963	80806
483+00	39.5	6.4	15.3	4.0	99784	18967	80817
484+00	25.3	18.4	120.0	45.9	99904	19013	80891
485+04	27.6	17.3	101.7	68.6	100006	19081	80925
EDGEWOOD AVENUE			290.0	18.0	100296	19099	81197
486+51	45.9	12.6	200.9	81.7	100497	19181	81316
487+00	34.1	27.4	72.2	36.1	100569	19217	81352
487+44	30.1	51.3	52.3	64.1	100621	19281	81340
488+00	28.9	40.2	61.2	94.9	100682	19376	81306
489+00	33.7	35.5	115.9	140.2	100798	19516	81282
490+00	45.8	27.6	147.2	116.9	100945	19633	81312
491+00	65.3	18.0	205.7	84.4	101151	19717	81434
492+00	64.6	19.2	240.6	68.9	101392	19786	81605
493+00	43.8	28.7	200.7	88.7	101592	19875	81717
494+00	26.2	32.0	129.6	112.4	101722	19987	81735
494+20	36.8	45.0	23.3	28.5	101745	20016	81729
495+00	60.7	12.2	144.5	84.7	101890	20101	81789
495+85	95.9	3.2	246.5	24.2	102136	20125	82011
496+00	101.1	2.9	54.7	1.7	102191	20127	82064

9

9

CTH Z (includes sideroads) CONT'D

EXP Fact=30%

STATION	END AREA		VOLUME		CUMULATIVE VOLUME		MASS HAUL (C.Y.)
	CUT (S.F.)	FILL (S.F.)	CUT (C.Y.)	FILL (C.Y.)	CUT (C.Y.)	FILL (C.Y.)	
496+55	127.2	2.9	231.7	5.9	102423	20132	82290
NEW ROAD			211.0	0.0	102634	20132	82501
497+45	174.4	0.0	503.6	4.8	103137	20137	83000
497+85	165.4	0.0	250.4	0.0	103388	20137	83250
498+00	158.8	0.0	91.2	0.0	103479	20137	83342
498+20	171.8	0.0	122.4	0.0	103601	20137	83464
499+00	94.8	4.8	394.8	7.1	103996	20144	83852
500+00	39.7	8.5	249.0	24.7	104245	20169	84076
501+00	18.5	17.6	107.8	48.4	104353	20217	84135
501+90	66.2	4.7	141.2	37.2	104494	20255	84239
502+00	73.7	0.0	25.9	0.9	104520	20256	84265
502+15	73.4	0.0	40.9	0.0	104561	20256	84305
503+00	33.9	13.0	168.9	20.5	104730	20276	84454
504+00	21.5	23.4	102.6	67.4	104832	20343	84489
504+70	21.4	33.6	55.6	73.9	104888	20417	84471
505+00	19.8	30.3	22.9	35.5	104911	20453	84458
505+20	24.0	16.7	16.2	17.4	104927	20470	84457
506+00	45.9	17.6	103.6	50.8	105031	20521	84510
506+40	97.5	5.8	106.2	17.3	105137	20538	84599
507+00	137.4	0.7	261.0	7.2	105398	20546	84852
507+70	44.1	17.5	235.3	23.6	105633	20569	85064
508+00	5.3	31.4	27.4	27.2	105661	20596	85064
509+00	2.6	61.7	14.6	172.4	105675	20769	84907
510+00	5.0	39.3	14.1	187.0	105689	20956	84734
511+00	9.7	29.0	27.2	126.5	105717	21082	84634
511+57	13.1	9.1	24.1	40.2	105741	21122	84618
EAGLE DRIVE			154.0	0.0	105895	21122	84772
512+87	35.2	7.9	116.3	40.9	106011	21163	84848
513+00	32.5	8.6	16.3	4.0	106027	21167	84860
514+00	22.6	16.8	102.0	47.0	106129	21214	84915
515+00	17.3	24.3	73.9	76.1	106203	21290	84913
515+30	22.4	14.7	22.1	21.7	106225	21312	84913
516+00	20.6	22.6	55.7	48.4	106281	21361	84920
517+00	21.2	24.0	77.4	86.3	106358	21447	84911
518+00	34.0	12.0	102.2	66.7	106461	21513	84947
518+15	35.4	11.6	19.3	6.6	106480	21520	84960
519+00	28.2	16.8	100.1	44.7	106580	21565	85015
520+00	23.9	17.6	96.5	63.7	106676	21628	85048
521+00	21.1	16.8	83.3	63.7	106760	21692	85068
522+00	18.9	17.1	74.1	62.8	106834	21755	85079
523+00	18.9	18.1	70.0	65.2	106904	21820	85084
524+00	36.3	10.7	102.2	53.3	107006	21873	85133
524+74	55.2	4.8	125.4	21.2	107131	21895	85237
EAGLE COURT			115.0	4.0	107246	21899	85348
525+35	63.8	0.0	134.4	5.4	107381	21904	85477
526+10	36.7	12.0	139.6	16.7	107520	21921	85600
527+00	17.2	23.5	89.8	59.2	107610	21980	85630
528+00	18.5	17.5	66.1	75.9	107676	22056	85621
528+20	19.0	29.6	13.9	17.4	107690	22073	85617
529+00	18.0	18.8	54.8	71.7	107745	22145	85600
530+00	23.7	24.4	77.2	80.0	107822	22225	85597
531+00	47.2	7.8	131.3	59.6	107954	22285	85669
531+10	70.2	14.3	21.7	4.1	107975	22289	85687
532+00	165.3	0.2	392.5	24.2	108368	22313	86055
533+00	103.5	0.6	497.8	1.5	108866	22314	86551
533+25	72.1	19.5	81.3	9.3	108947	22324	86623
534+00	16.4	17.1	122.9	50.8	109070	22375	86695
534+79	16.2	27.0	47.7	64.5	109118	22439	86678
EAGLE AVENUE			159.0	0.0	109277	22439	86837
536+09	49.1	13.3	157.2	97.0	109434	22536	86898
537+00	68.3	11.5	197.8	41.8	109632	22578	87054
538+00	79.7	13.3	274.1	45.9	109906	22624	87282
OUTFALL 1			328.0	0.0	110234	22624	87610
539+00	113.3	18.0	357.4	58.0	110591	22682	87909
540+00	51.9	19.0	305.9	68.5	110897	22750	88147
541+00	26.1	17.8	144.4	68.1	111041	22818	88223
542+00	27.2	14.8	98.7	60.4	111140	22879	88261
543+00	39.4	8.2	123.3	42.6	111263	22921	88342
544+00	25.6	8.5	120.4	30.9	111384	22952	88432
544+45	29.2	1.6	45.7	8.4	111429	22961	88469

CTH Z (includes sideroads) CONT'D

EXP Fact=30%

STATION	END AREA		VOLUME		CUMULATIVE VOLUME		MASS HAUL (C.Y.)
	CUT (S.F.)	FILL (S.F.)	CUT (C.Y.)	FILL (C.Y.)	CUT (C.Y.)	FILL (C.Y.)	
545+00	16.9	13.4	47.0	15.3	111476	22976	88500
546+00	8.6	15.2	47.2	53.0	111524	23029	88495
547+00	64.1	1.4	134.6	30.7	111658	23060	88599
548+00	155.3	0.0	406.3	2.6	112065	23062	89002
549+00	204.0	0.0	665.4	0.0	112730	23062	89668
550+00	234.6	0.0	812.2	0.0	113542	23062	90480
551+00	220.4	0.0	842.6	0.0	114385	23062	91322
552+00	144.5	0.0	675.7	0.0	115061	23062	91998
553+00	56.8	0.4	372.8	0.7	115433	23063	92370
554+00	47.5	2.5	193.1	5.4	115626	23068	92558
554+15	52.9	28.1	27.9	8.5	115654	23077	92577
555+00	63.9	10.2	183.9	60.3	115838	23137	92701
556+00	40.3	8.8	193.0	35.2	116031	23172	92859
557+00	120.0	5.5	296.9	26.5	116328	23199	93129
OUTFALL 2			323.0	0.0	116651	23199	93452
557+50	153.4	4.3	253.1	9.1	116904	23208	93696
558+00	117.4	4.1	250.7	7.8	117155	23216	93939
559+00	69.1	3.8	345.4	14.6	117500	23230	94270
560+00	43.7	2.8	208.9	12.2	117709	23243	94467
561+00	25.5	3.1	128.1	10.9	117837	23253	94584
562+00	22.1	8.7	88.1	21.9	117925	23275	94650
563+00	32.8	10.4	101.7	35.4	118027	23311	94716
564+00	32.7	9.9	121.3	37.6	118148	23348	94800
565+00	35.6	6.5	126.5	30.4	118275	23379	94896
566+00	42.5	4.8	144.6	20.9	118420	23400	95020
566+40	52.4	14.6	70.3	14.4	118490	23414	95076
567+00	62.1	3.7	127.2	20.3	118617	23434	95183
568+00	81.9	2.4	266.7	11.3	118884	23446	95438
569+00	96.5	0.9	330.4	6.1	119214	23452	95762
570+00	175.9	0.0	504.4	1.7	119719	23453	96265
OUTFALL 3			292.0	5.0	120011	23458	96552
570+70	217.9	0.0	510.5	0.0	120521	23458	97063
571+00	193.3	0.0	228.4	0.0	120749	23458	97291
572+00	148.8	0.0	633.5	0.0	121383	23458	97925
573+00	117.9	0.0	493.9	0.0	121877	23458	98418
573+94	88.8	5.7	359.8	9.9	122237	23468	98768
DYKE DRIVE			262.0	0.0	122499	23468	99030
575+23	83.1	2.1	410.7	18.6	122909	23487	99422
576+00	62.0	10.2	206.9	17.5	123116	23504	99612
577+00	47.8	12.2	203.3	41.5	123320	23546	99774
578+00	31.4	14.8	146.7	50.0	123466	23596	99870
579+00	32.1	12.1	117.6	49.8	123584	23646	99938
580+00	38.2	10.3	130.2	41.5	123714	23687	100027
580+92	53.5	14.7	156.2	42.6	123870	23730	100140
581+00	65.5	7.4	17.6	3.3	123888	23733	100155
582+00	29.7	17.0	176.3	45.2	124064	23778	100286
583+00	6.4	48.0	66.9	120.4	124131	23899	100232
584+00	5.7	73.3	22.4	224.6	124153	24123	100030
584+96	61.6	3.3	119.6	136.2	124273	24259	100014
LAKEVIEW DRIVE			377.0	6.0	124650	24265	100385
586+26	196.5	0.0	621.4	7.9	125271	24273	100998
587+00	180.8	0.0	517.0	0.0	125788	24273	101515
587+30	176.9	0.0	198.7	0.0	125987	24273	101714
588+00	103.5	2.9	363.5	3.8	126351	24277	102073
588+30	86.7	19.2	105.7	12.3	126456	24289	102167
589+00	38.0	6.7	161.6	33.6	126618	24323	102295
590+00	20.8	20.6	108.9	50.6	126727	24374	102353
591+00	167.5	0.0	348.7	38.1	127076	24412	102664
591+50	231.3	0.0	369.3	0.0	127445	24412	103033
591+63	227.4	0.0	110.4	0.0	127555	24412	103144
592+00	185.4	0.0	282.8	0.0	127838	24412	103426
593+00	87.8	8.3	505.9	15.4	128344	24427	103917
594+00	58.8	13.0	271.5	39.4	128615	24467	104149
595+00	29.0	14.1	162.6	50.2	128778	24517	104261
596+00	13.2	22.5	78.1	67.8	128856	24585	104272
597+00	45.0	20.4	107.8	79.4	128964	24664	104300
597+30	67.3	19.6	62.4	22.2	129026	24686	104340
598+00	49.0	19.9	150.8	51.2	129177	24737	104440
599+00	49.9	18.3	183.1	70.7	129360	24808	104552
599+66	46.5	33.4	117.8	63.2	129478	24871	104607
PARK EXIT			59.0	19.0	129537	24890	104647

EDGEWOOD AVE LT & RT
485+76.72

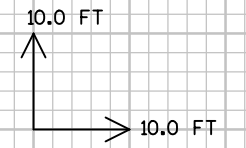
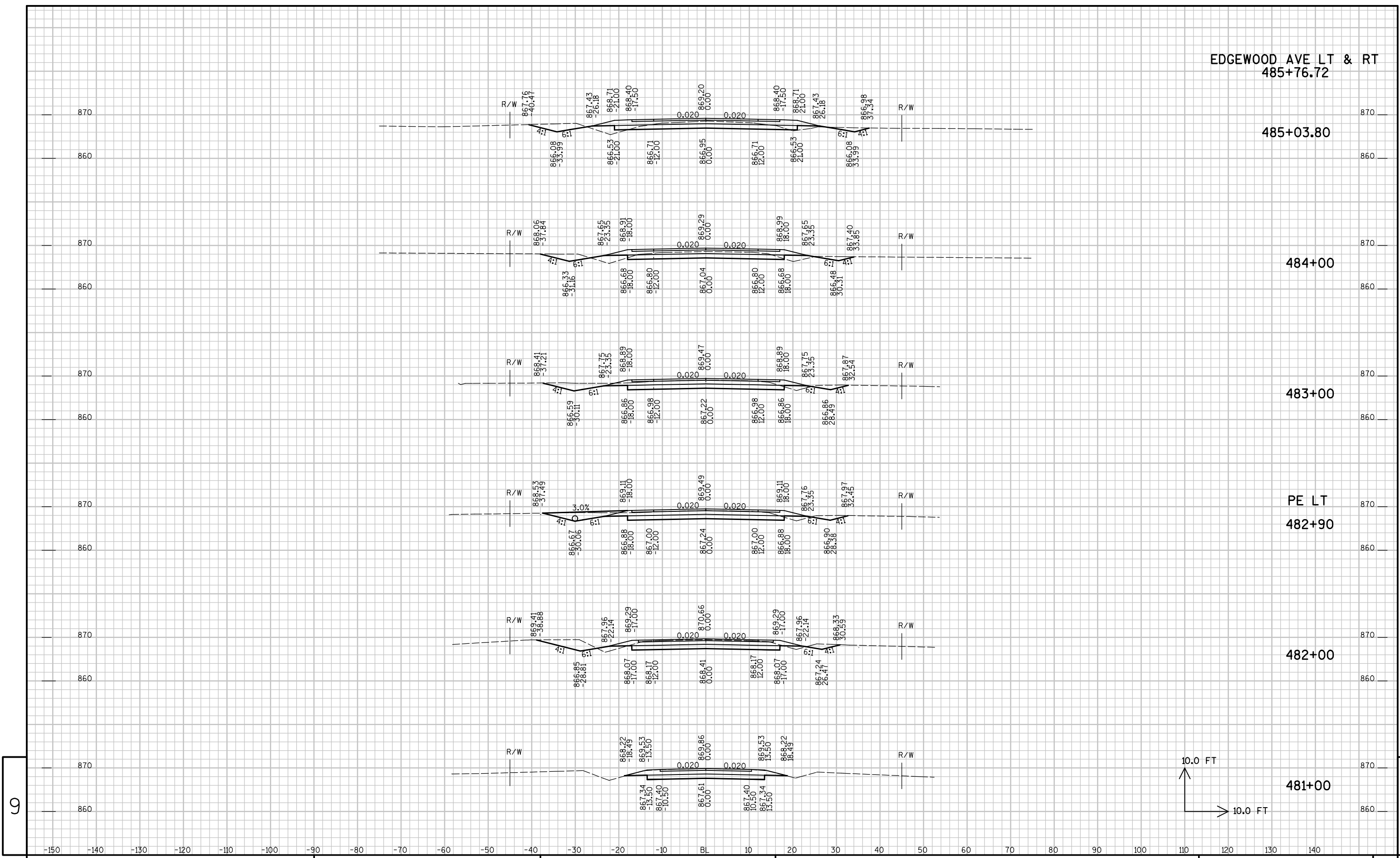

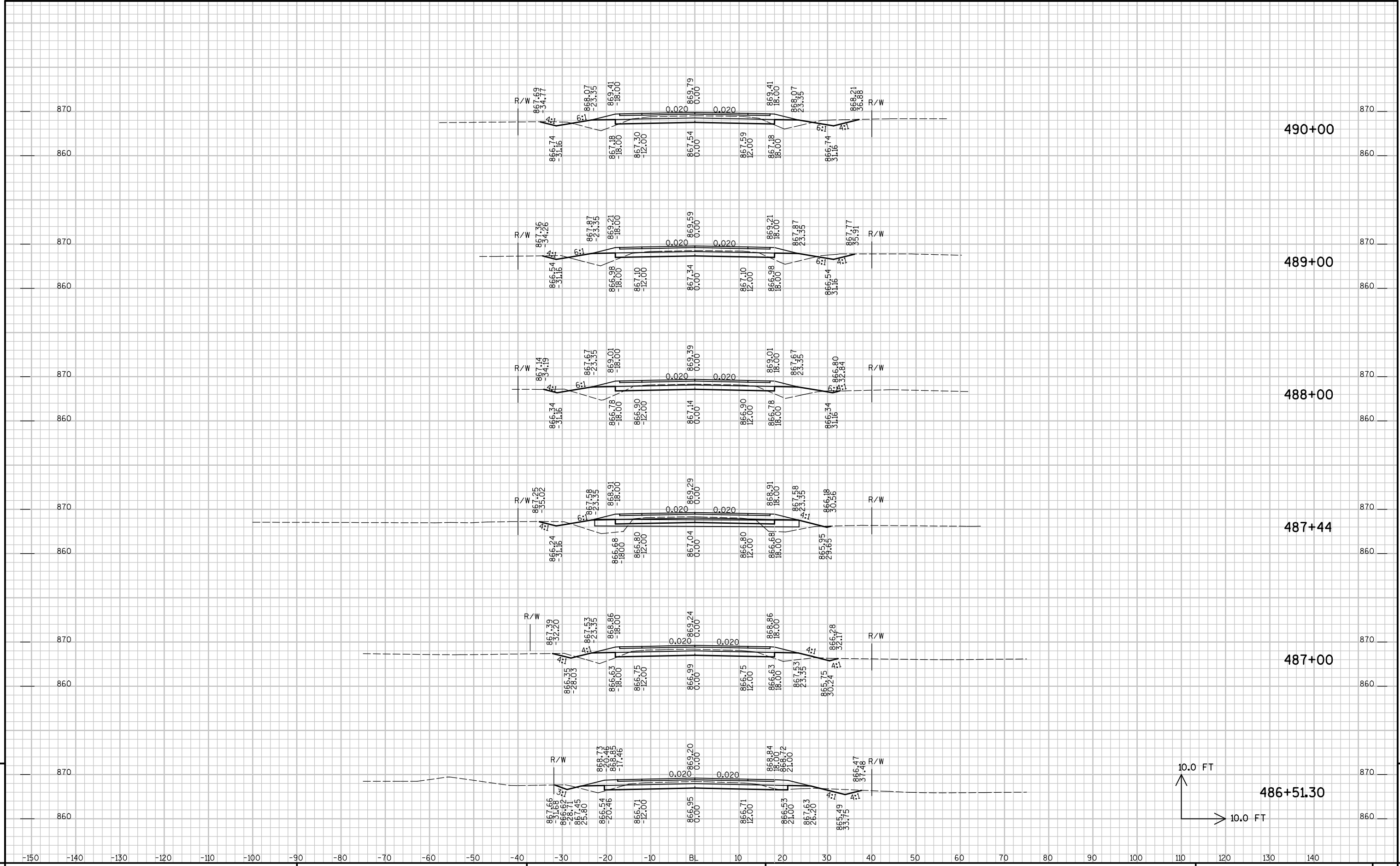

PROJECT NO : 6355-00-74

HWY : CTH Z

COUNTY : ADAMS

CROSS SECTIONS - CTH Z

SHEET NO:

E

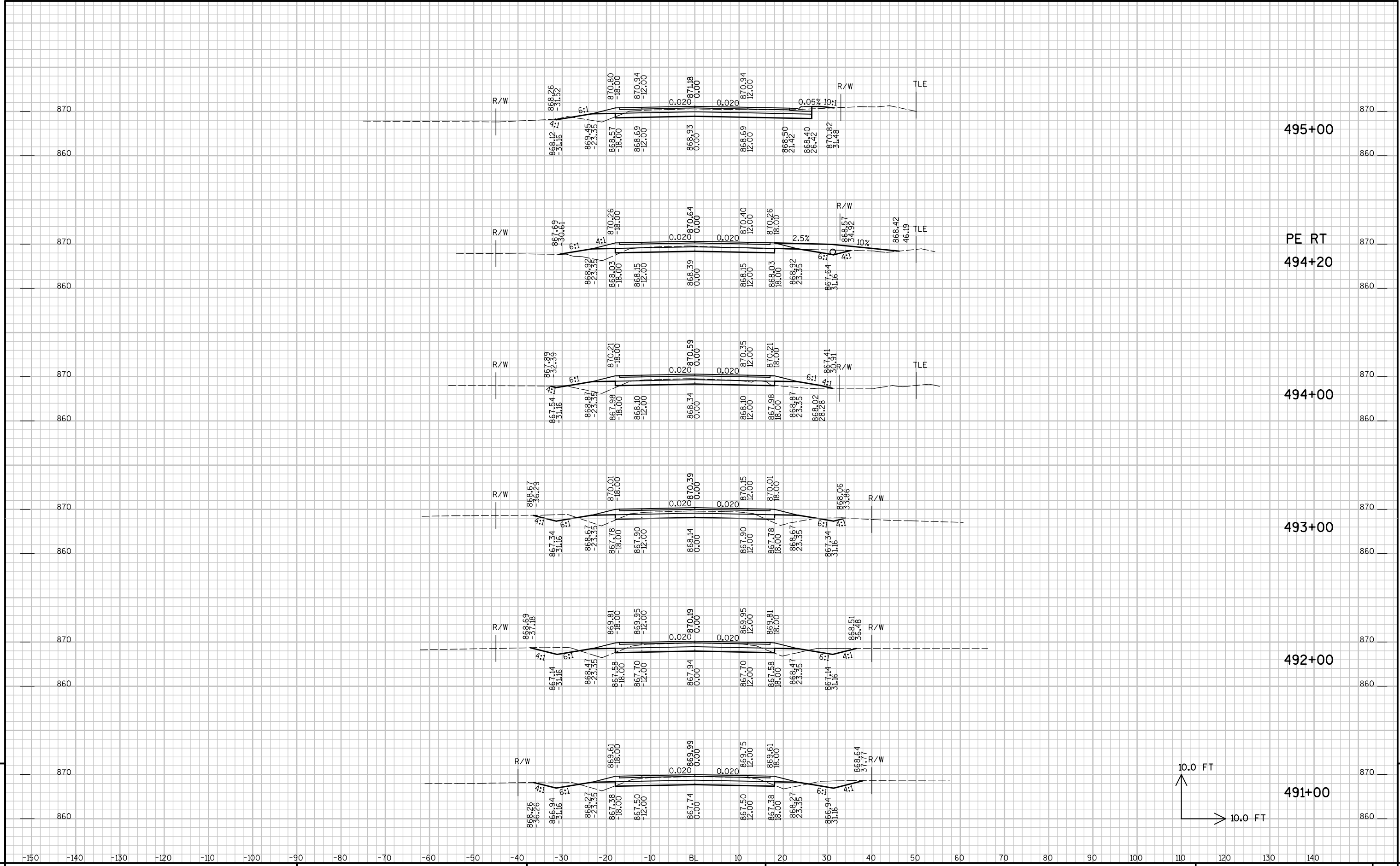

9

9

PROJECT NO : 6355-00-74 HWY : CTH Z COUNTY : ADAMS CROSS SECTIONS - CTH Z SHEET NO: E

FILE NAME : X:\AE\A\ADAMC\157311\5-final-dsgn\51-drawings\CAD\cad\XBCTHZ301-500.dgn PLOT TIME : 7:36:16 AM PLOT DATE : 2/9/2021 PLOT BY : SEH INC PLOT NAME : PLOT SCALE : Invalid expression

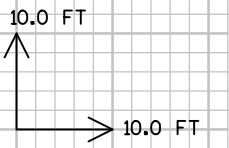

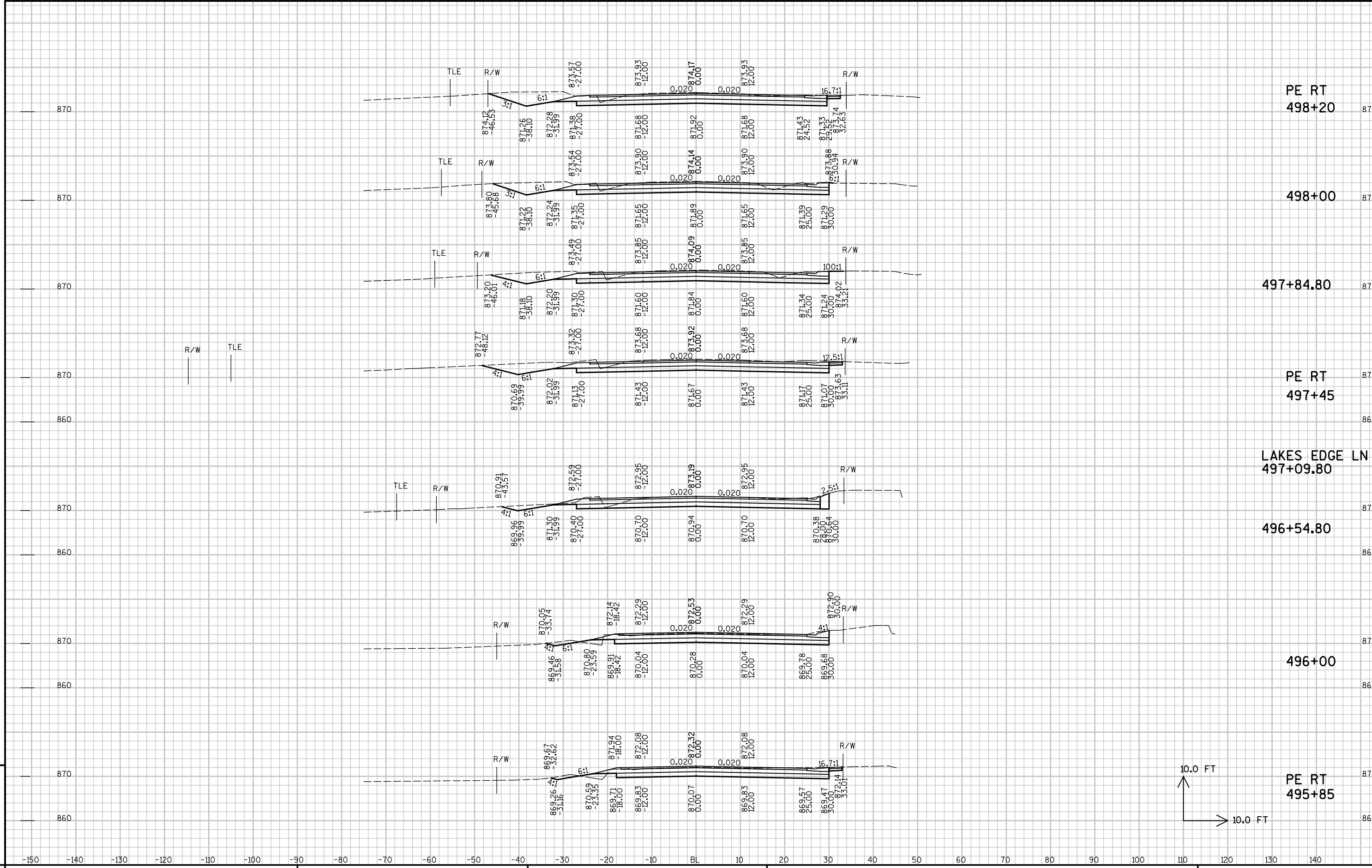

PROJECT NO : 6355-00-74

HWY : CTH Z

COUNTY : ADAMS

CROSS SECTIONS - CTH Z

SHEET NO:

9

9

E

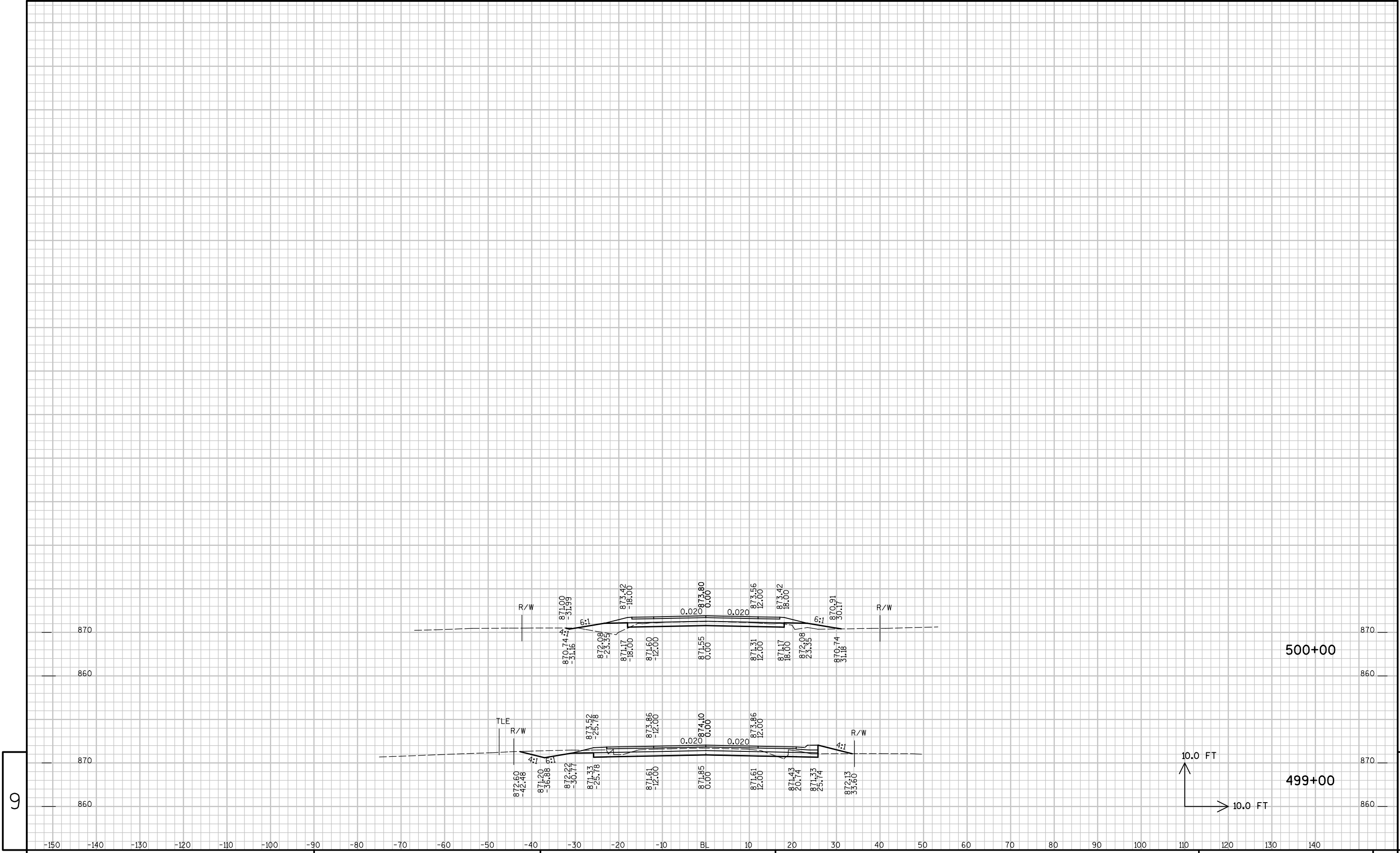

PROJECT NO : 6355-00-74

HWY : CTH Z

COUNTY : ADAMS

CROSS SECTIONS - CTH Z

SHEET NO:

E

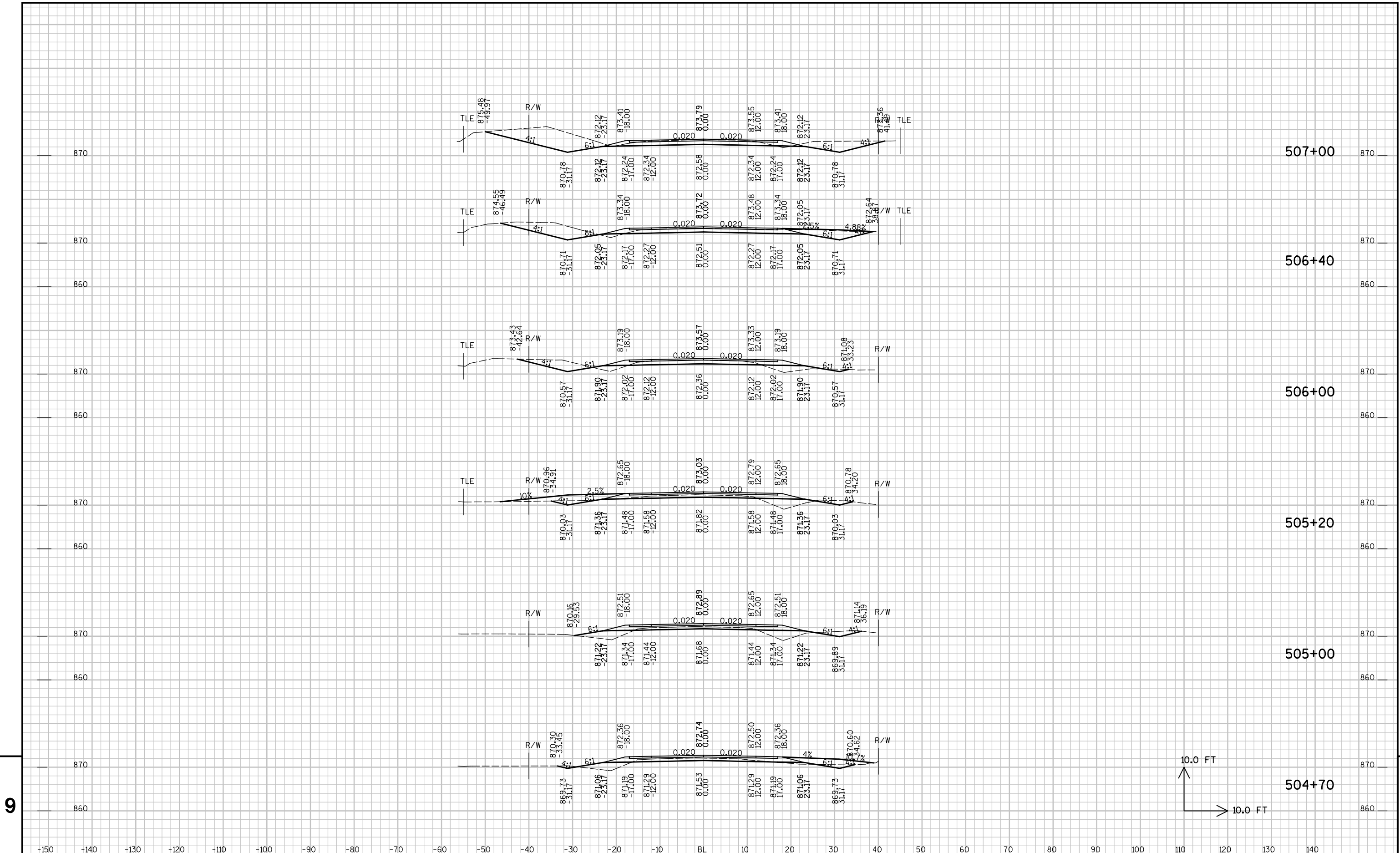

PROJECT NO : 6355-00-74

HWY : CTH Z

COUNTY : ADAMS

CROSS SECTIONS - CTH Z

SHEET NO:

E

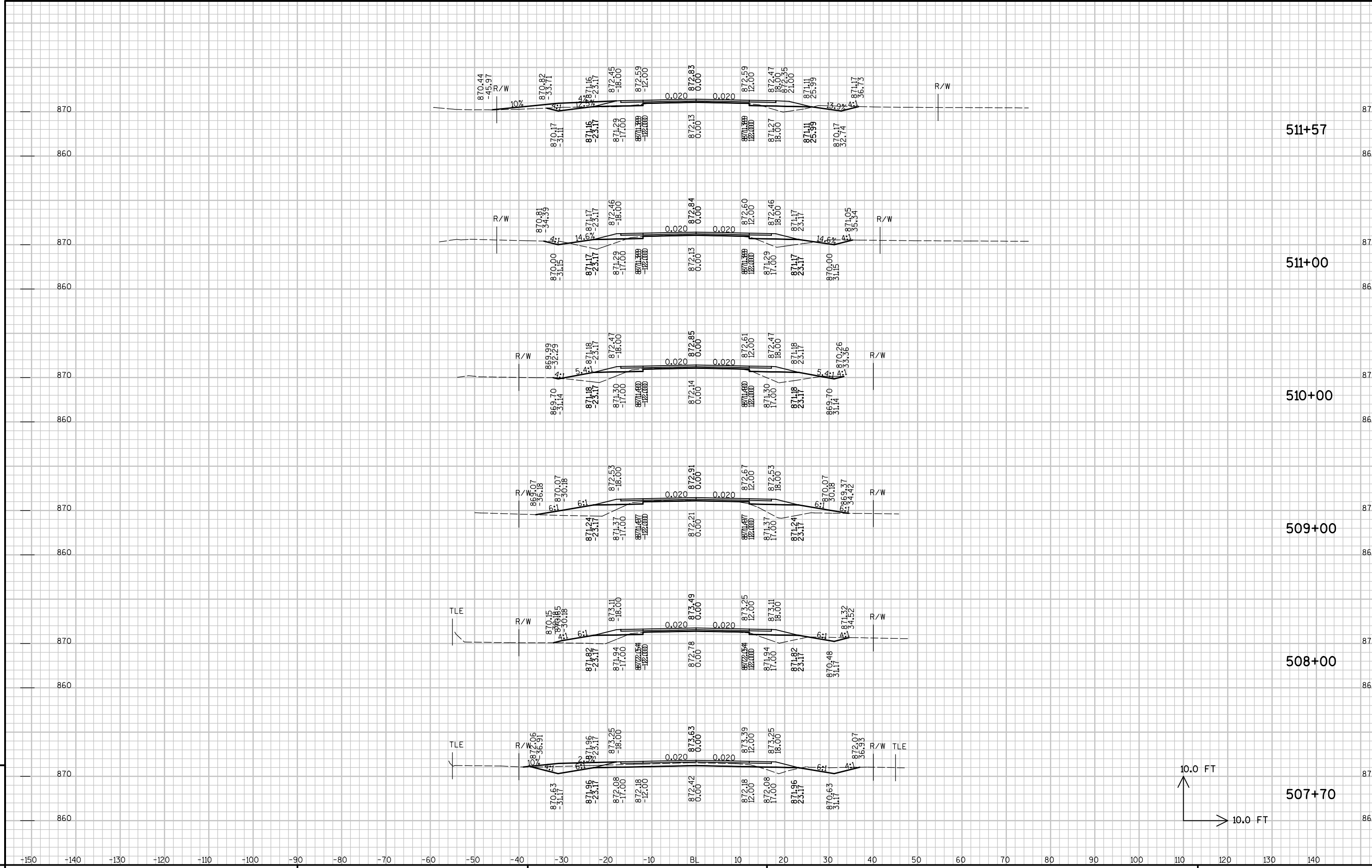

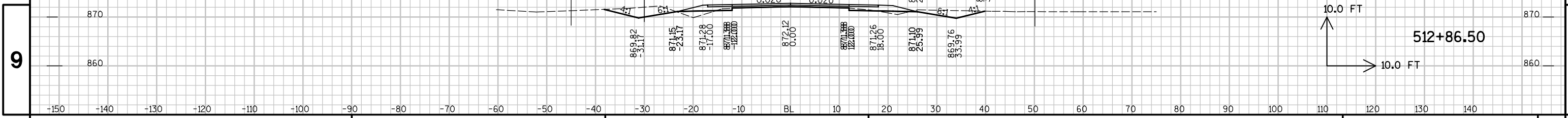
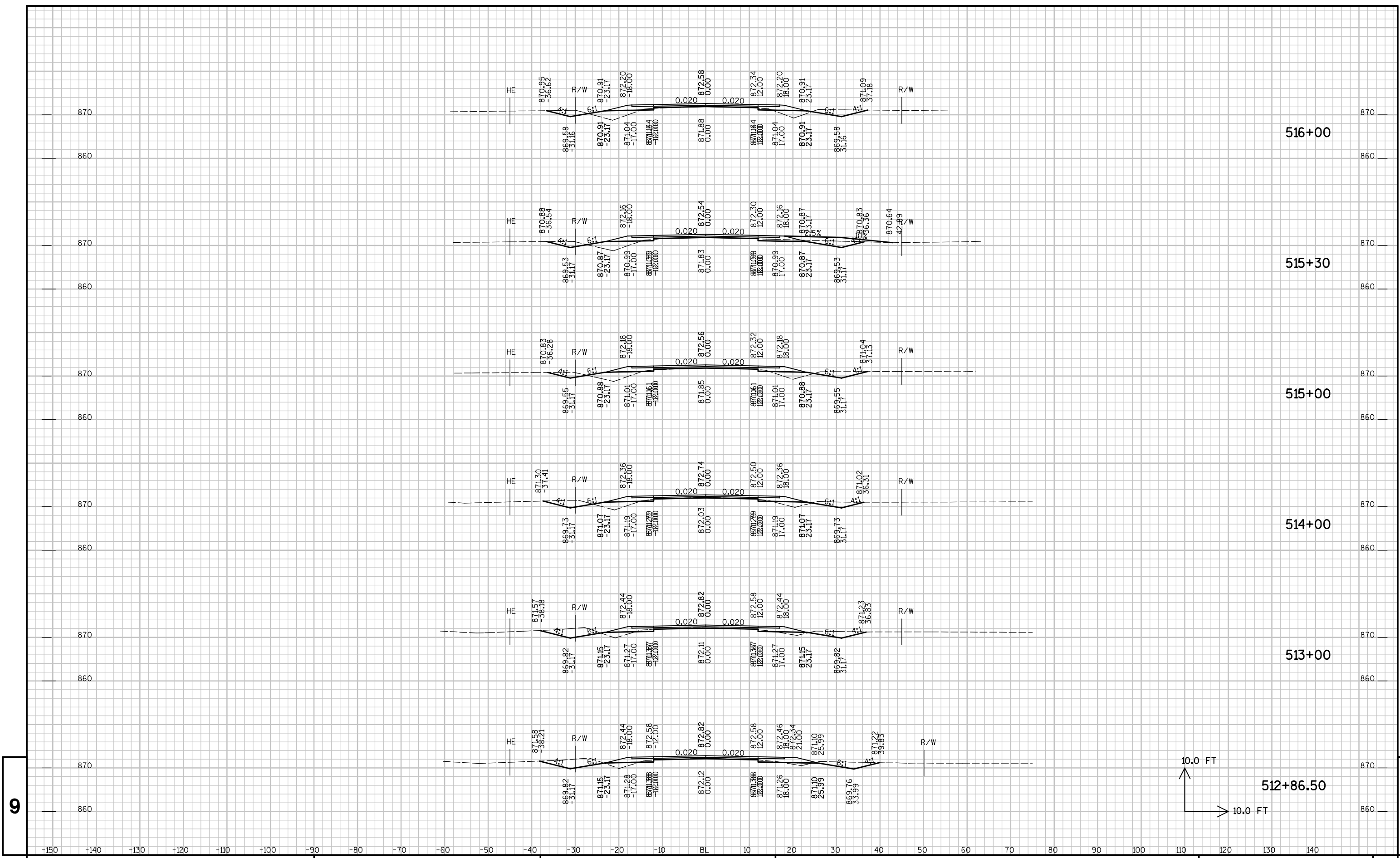

PROJECT NO : 6355-00-74 HWY : CTH Z COUNTY : ADAMS CROSS SECTIONS - CTH Z SHEET NO: E

FILE NAME : X:\AEVA\ADAMC\157311\5-final-dsgn\51-drawings\CAD\cad\XBCTHZ501-653.dgn PLOT TIME : 7:36:34 AM PLOT DATE : 2/9/2021 PLOT BY : SEH INC PLOT NAME : PLOT SCALE : Invalid expression

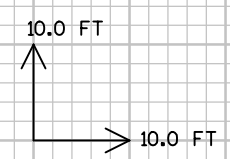
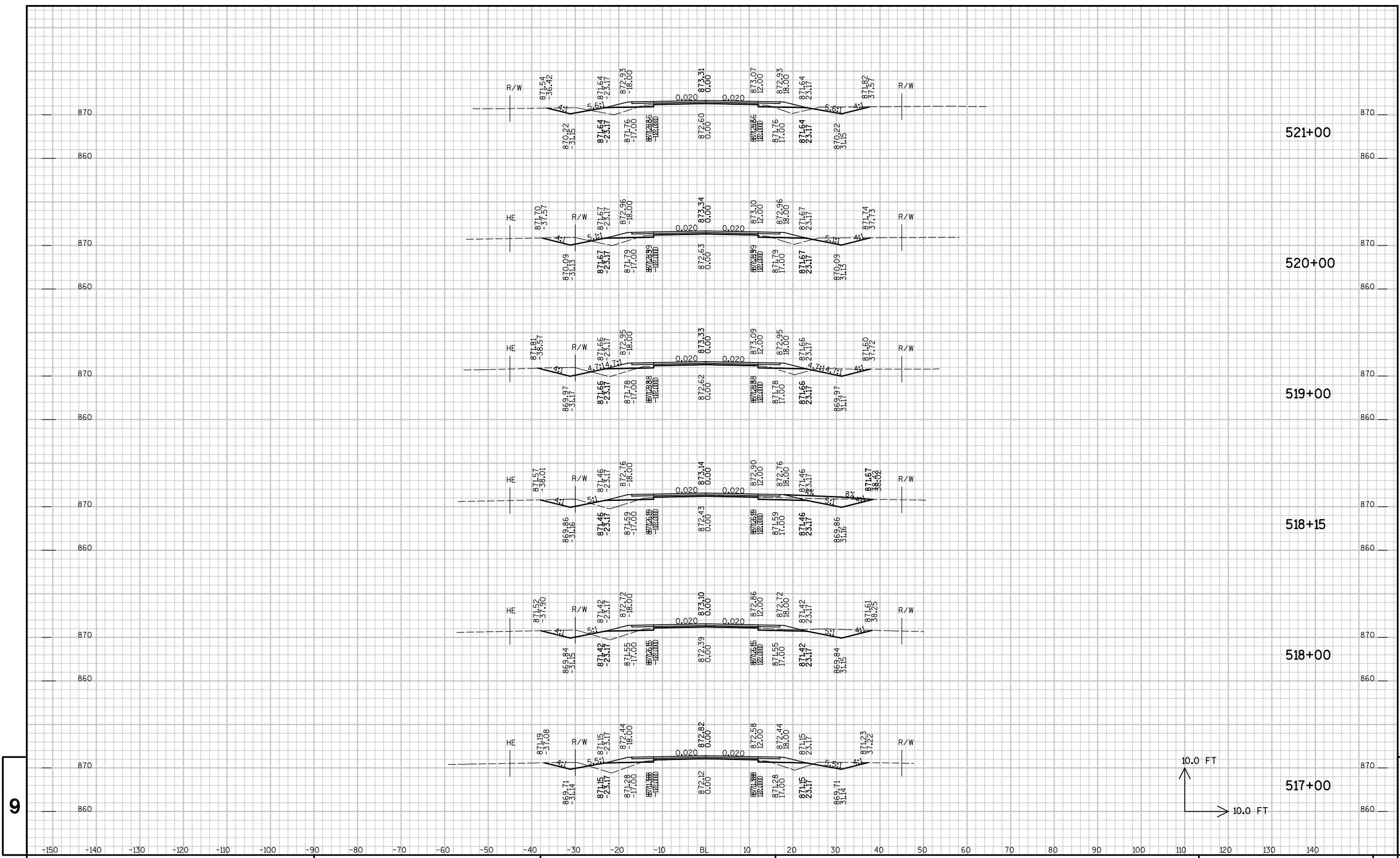

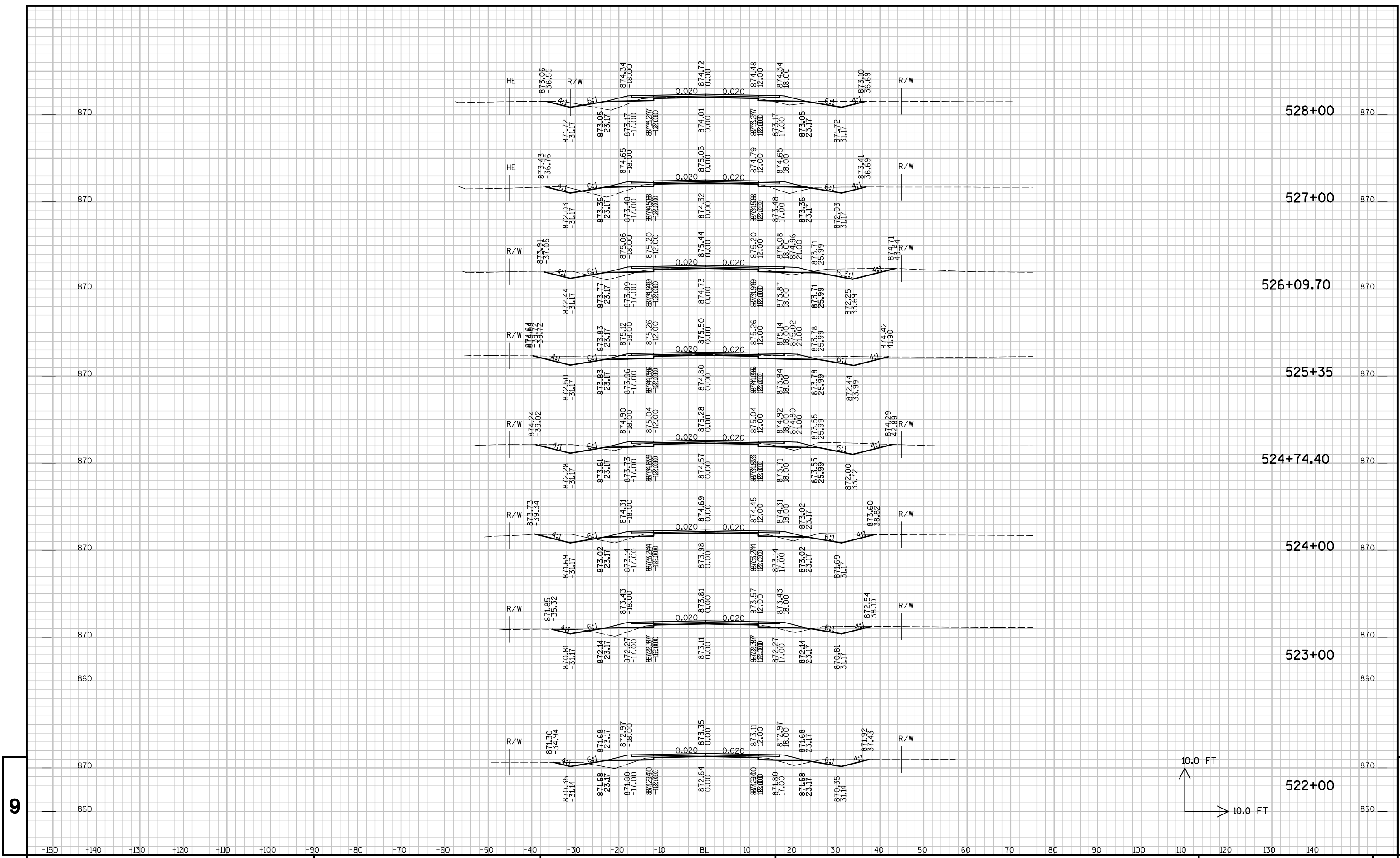

PROJECT NO : 6355-00-74

HWY : CTH Z

COUNTY : ADAMS

CROSS SECTIONS - CTH Z

SHEET NO:

E

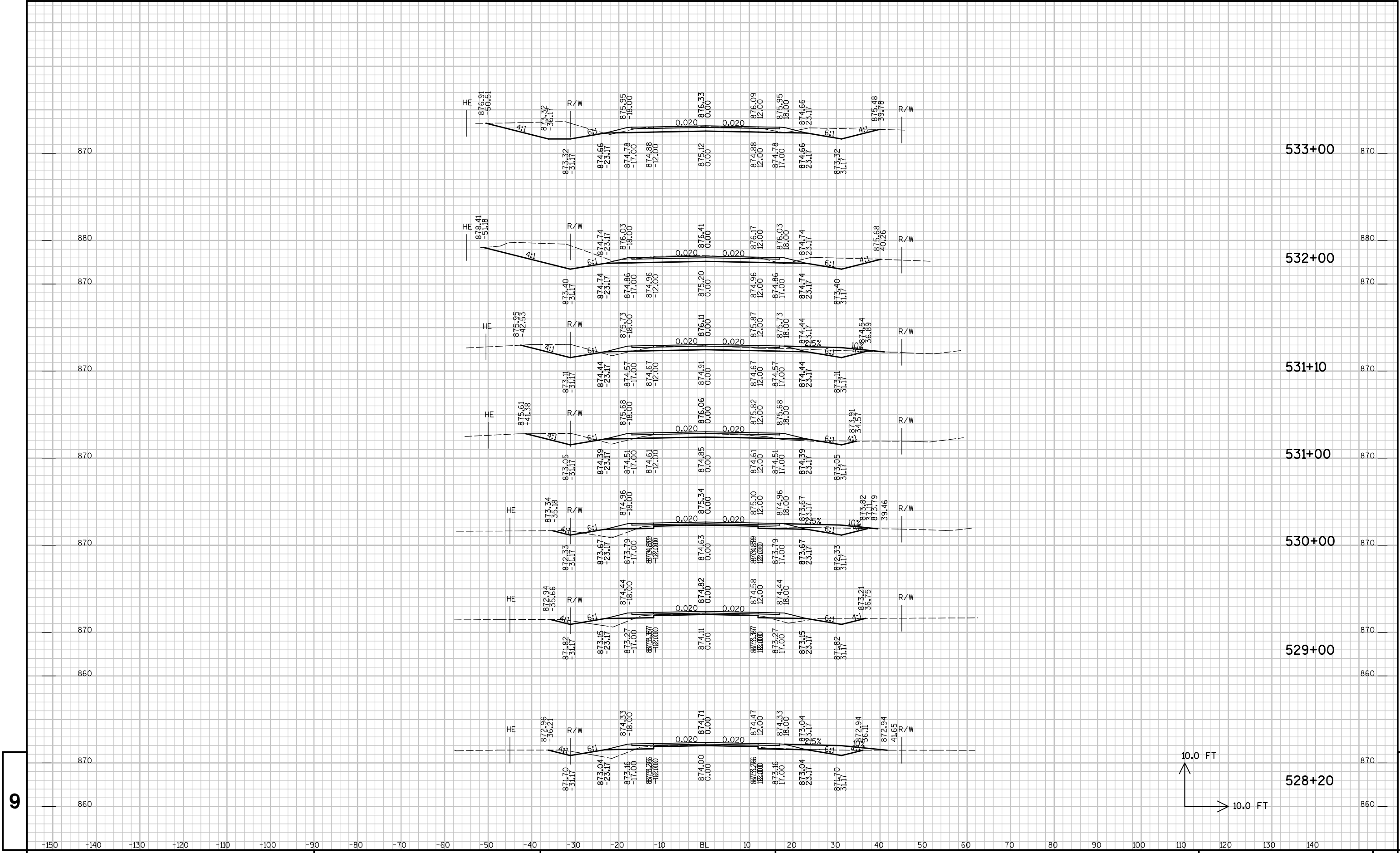

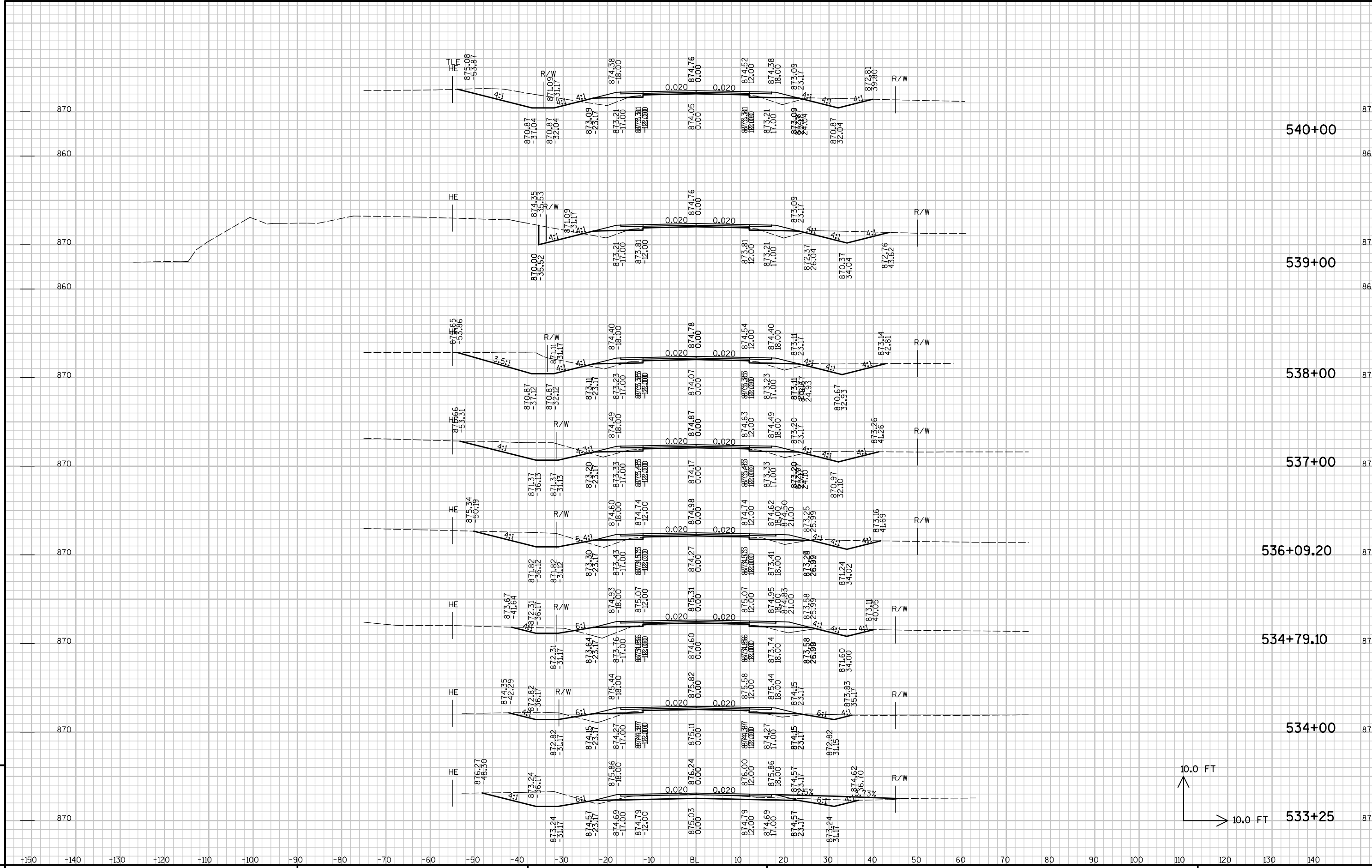

9

9



PROJECT NO : 6355-00-74 HWY : CTH Z COUNTY : ADAMS CROSS SECTIONS - CTH Z SHEET NO: E

FILE NAME : X:\AEVA\ADAMC\157311\5-final-dsgn\51-drawings\CAD\cad\XBCTH2501-653.dgn PLOT TIME : 7:36:38 AM PLOT DATE : 2/9/2021 PLOT BY : SEH INC PLOT NAME : PLOT SCALE : Invalid expression

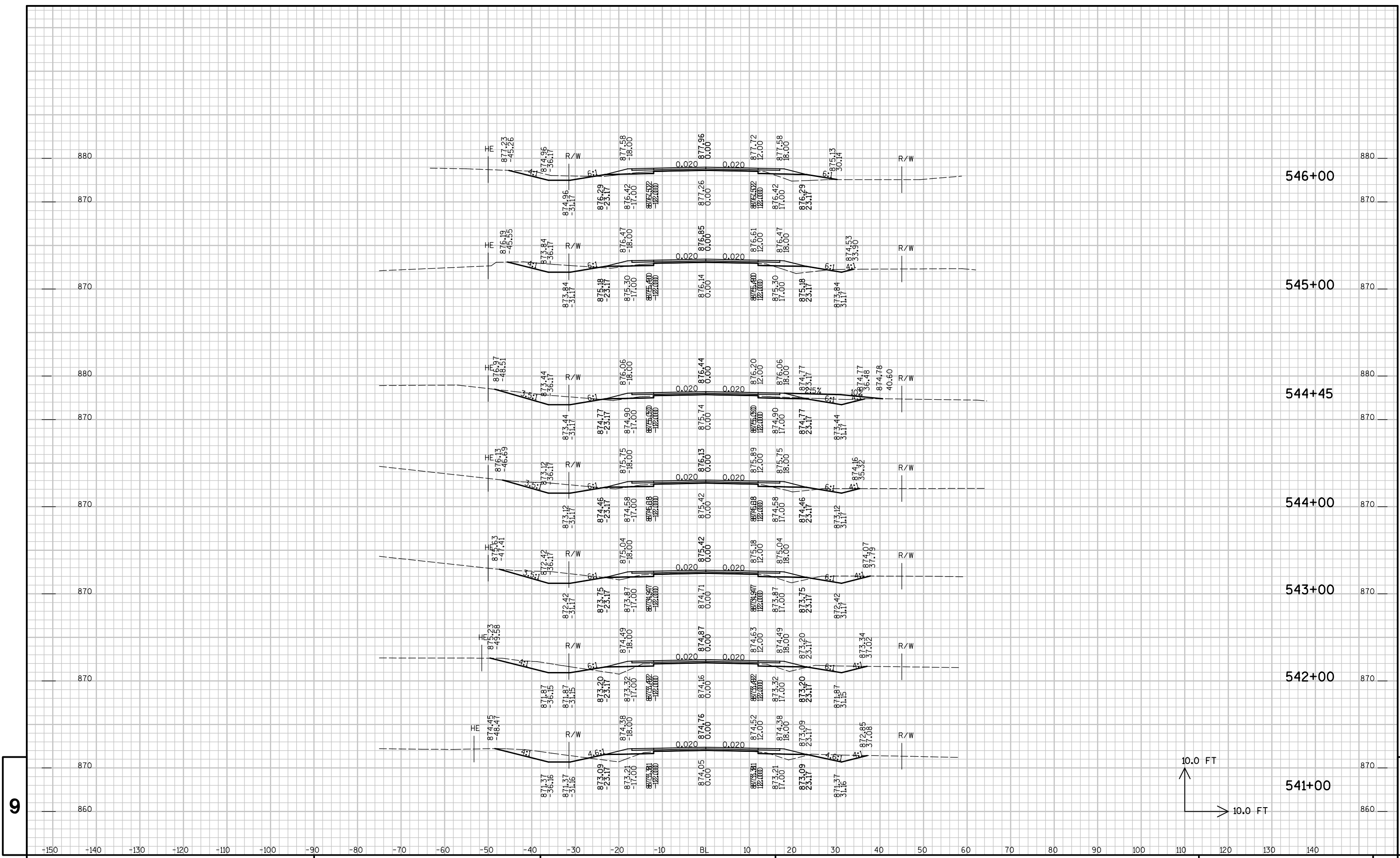

9	PROJECT NO : 6355-00-74	HWY : CTH Z	COUNTY : ADAMS	CROSS SECTIONS - CTH Z	SHEET NO:	E
---	-------------------------	-------------	----------------	------------------------	-----------	---

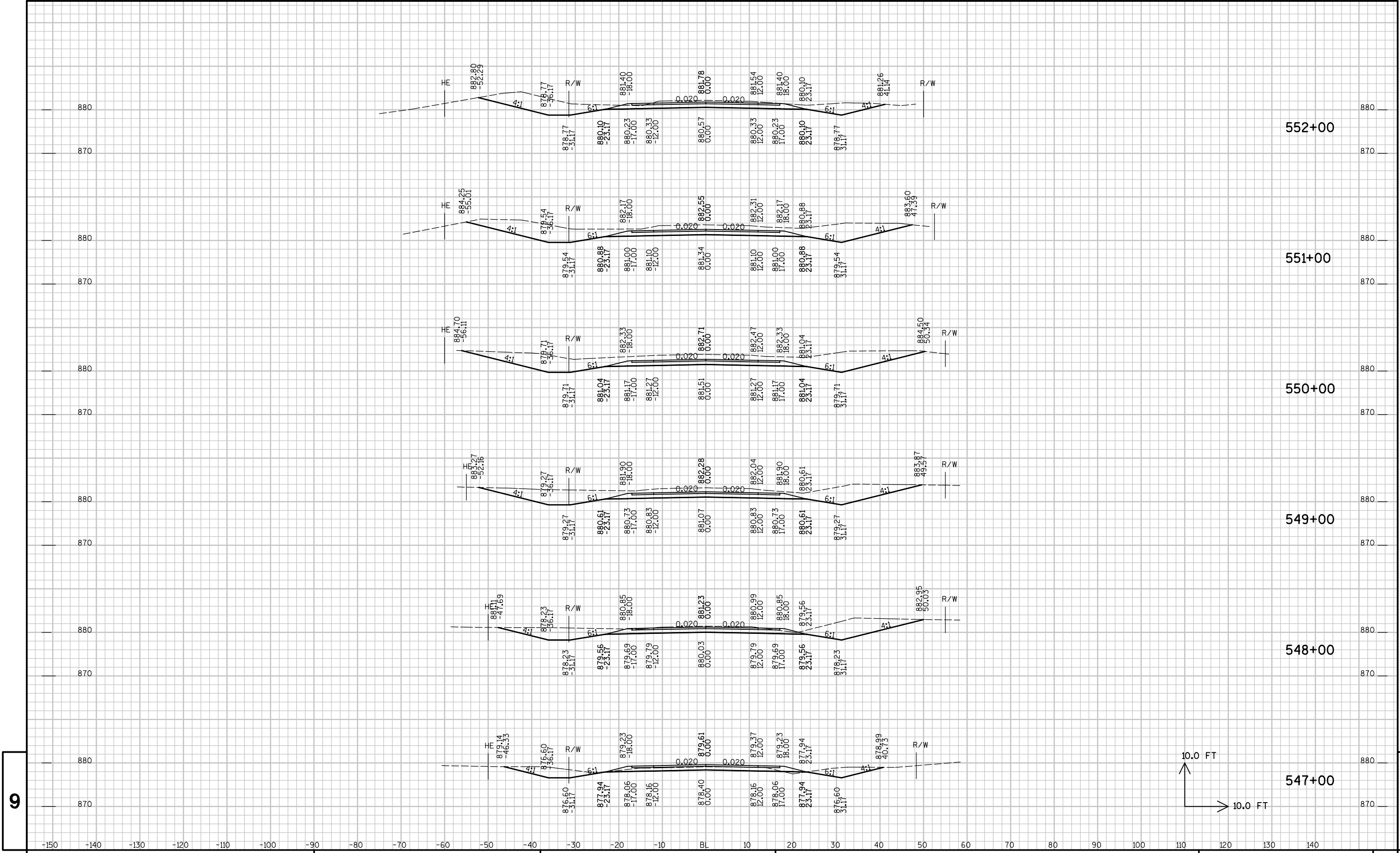

9	PROJECT NO : 6355-00-74	HWY : CTH Z	COUNTY : ADAMS	CROSS SECTIONS - CTH Z	SHEET NO:	E
---	-------------------------	-------------	----------------	------------------------	-----------	---

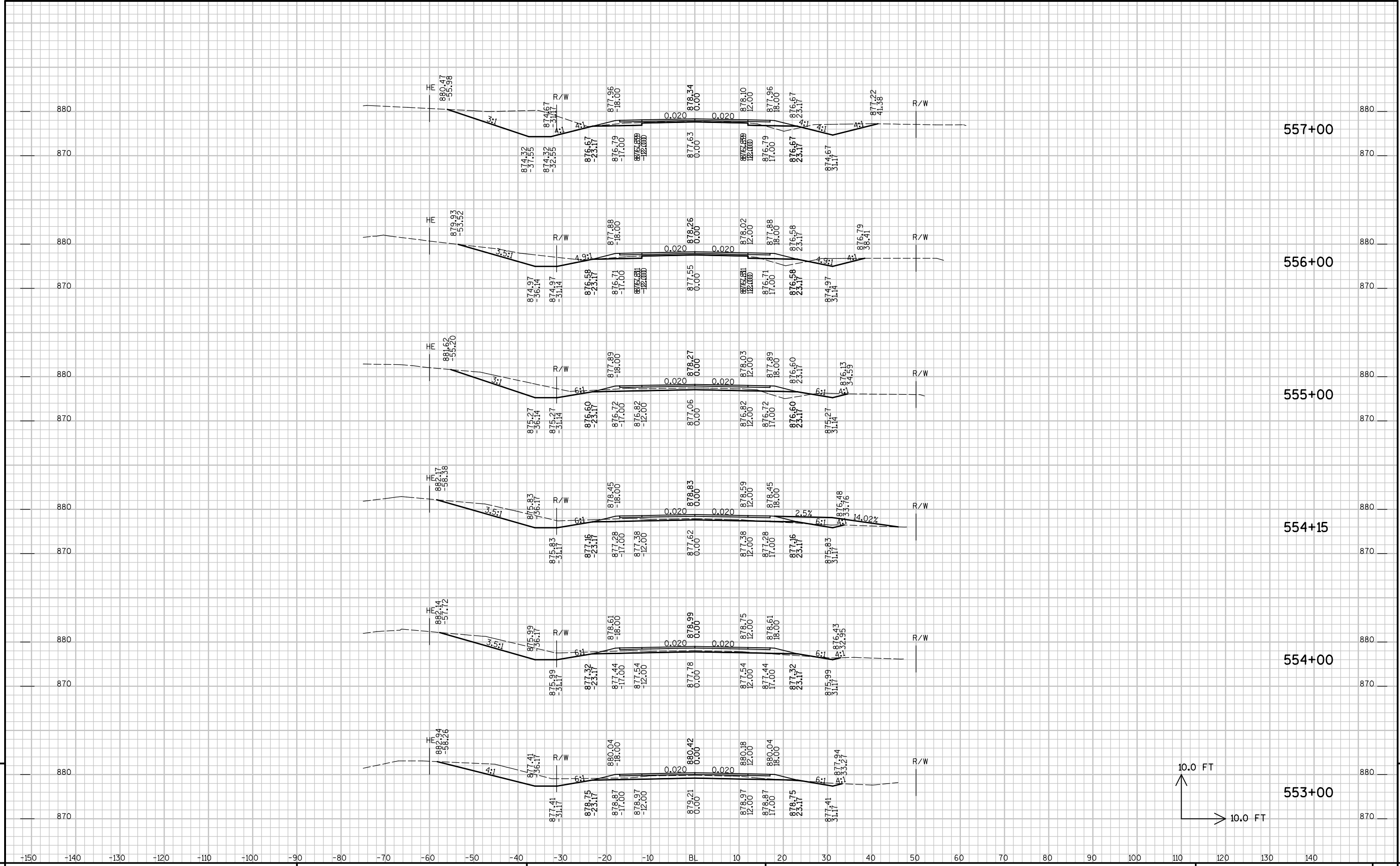

9

9

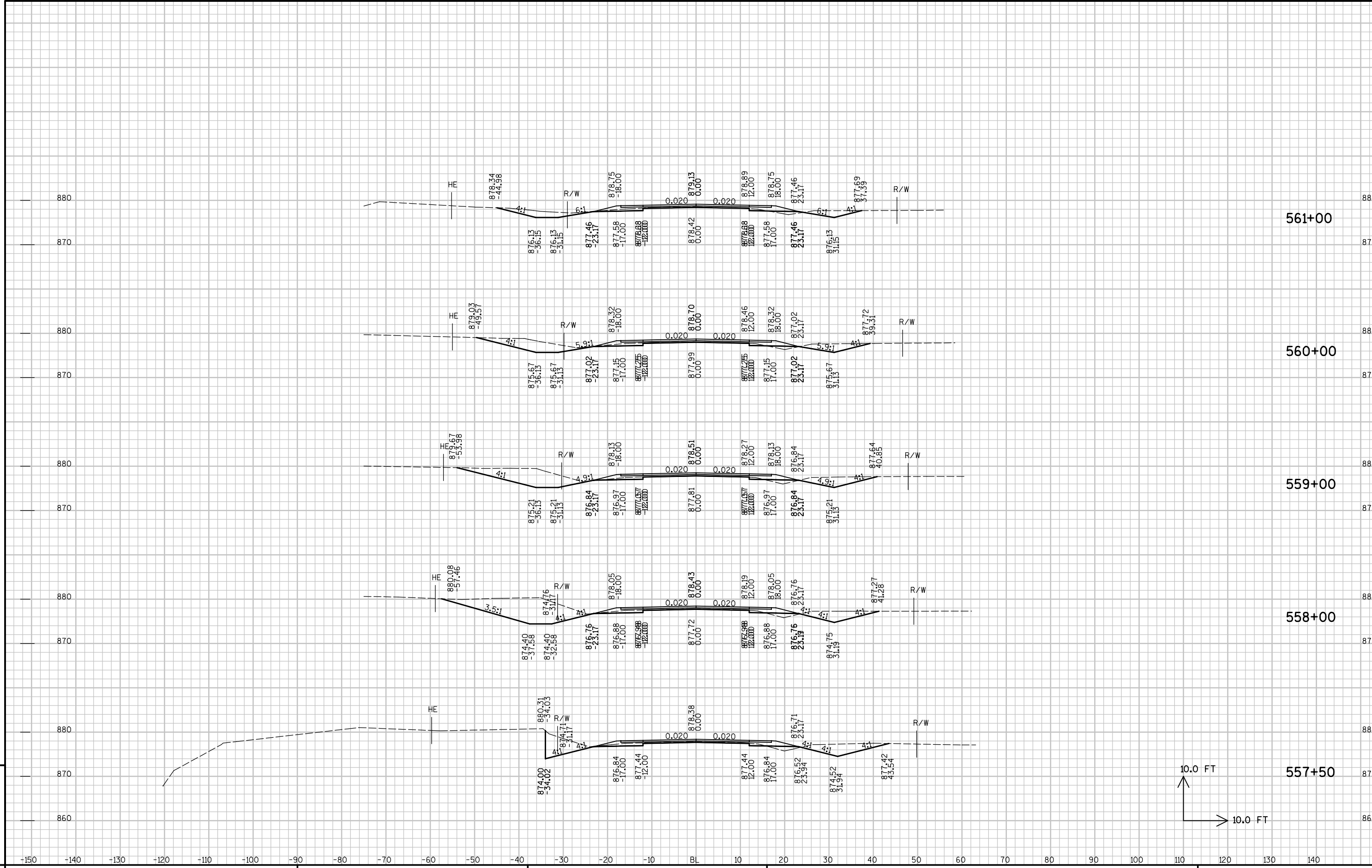

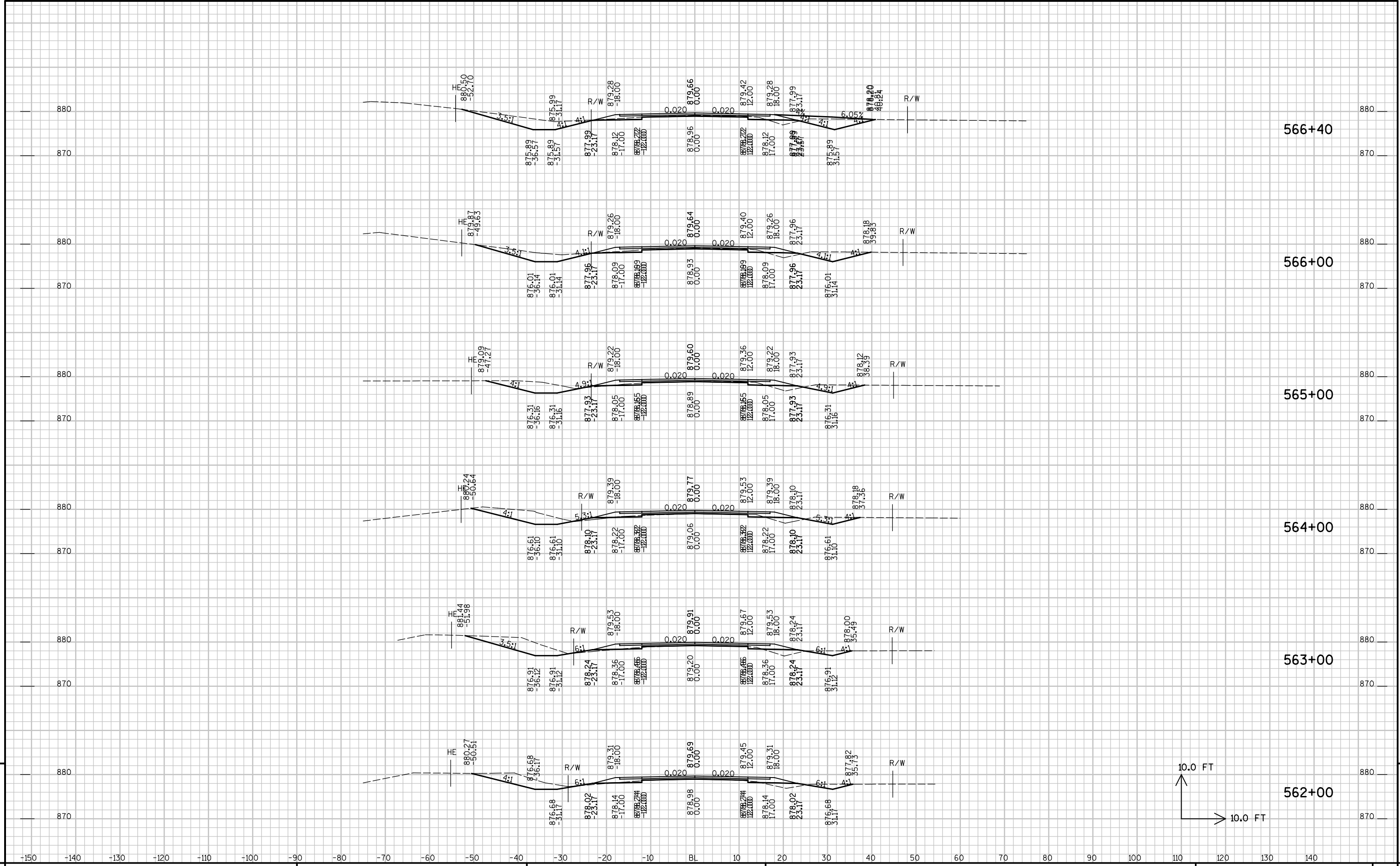

9

9

PROJECT NO : 6355-00-74 HWY : CTH Z COUNTY : ADAMS CROSS SECTIONS - CTH Z SHEET NO: E

FILE NAME : X:\AE\ADAMC\157311\5-final-dsgr\51-drawings\CAD\cad\XBCTH2501-653.dgn PLOT TIME : 7:36:43 AM PLOT DATE : 2/9/2021 PLOT BY : SEH INC PLOT NAME : PLOT SCALE : Invalid expression

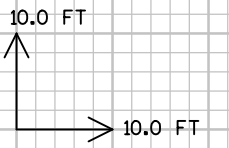

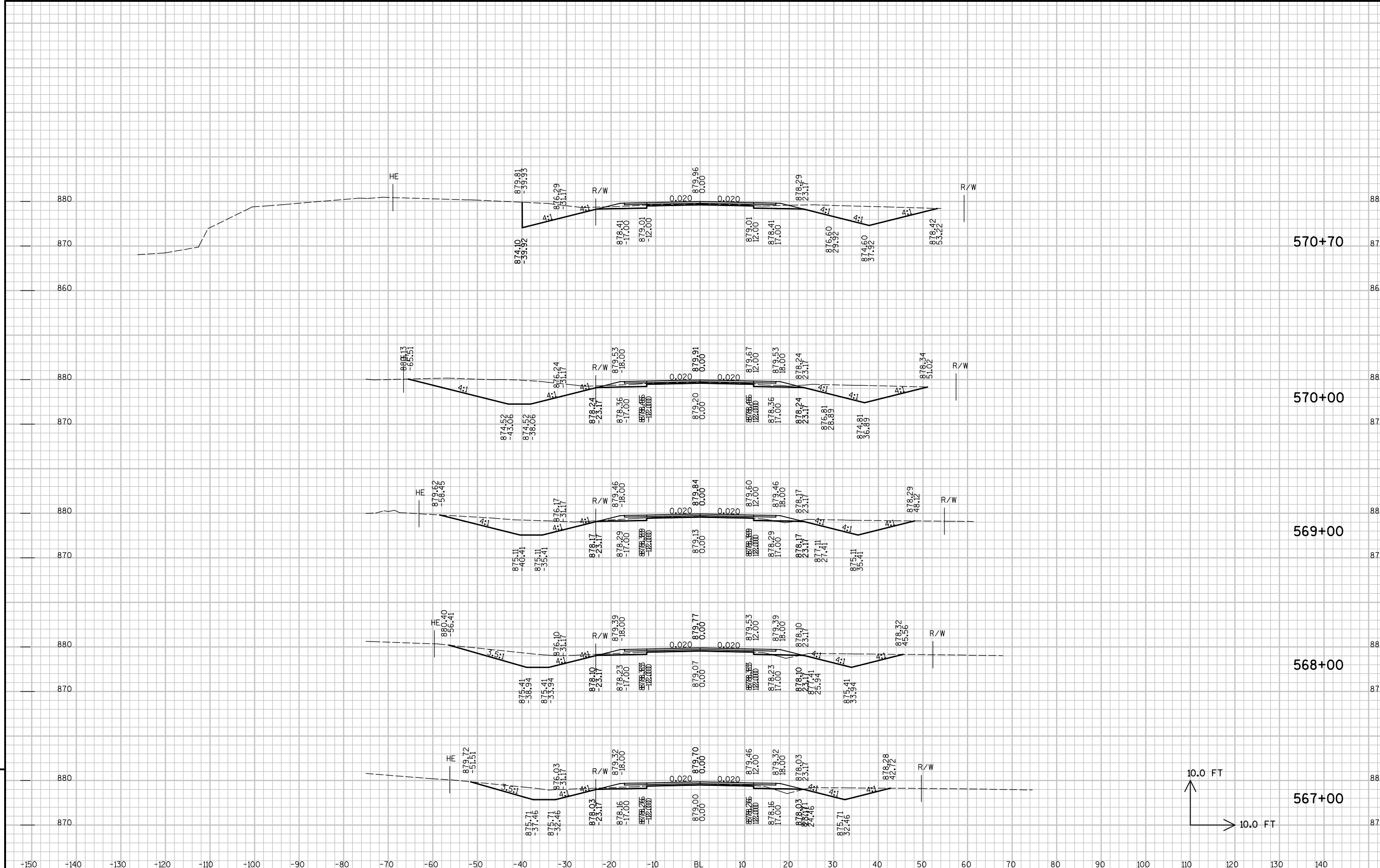

PROJECT NO : 6355-00-74

HWY : CTH Z

COUNTY : ADAMS

CROSS SECTIONS - CTH Z

SHEET NO:

E

FILE NAME : X:\AE\ADAMC\157311\5-final-dsgr\51-drawings\CAD\cad\XBCTH2501-653.dgn

PLOT TIME : 7:36:44 AM

PLOT DATE : 2/9/2021

PLOT BY : SEH INC

PLOT NAME :

PLOT SCALE : Invalid expression

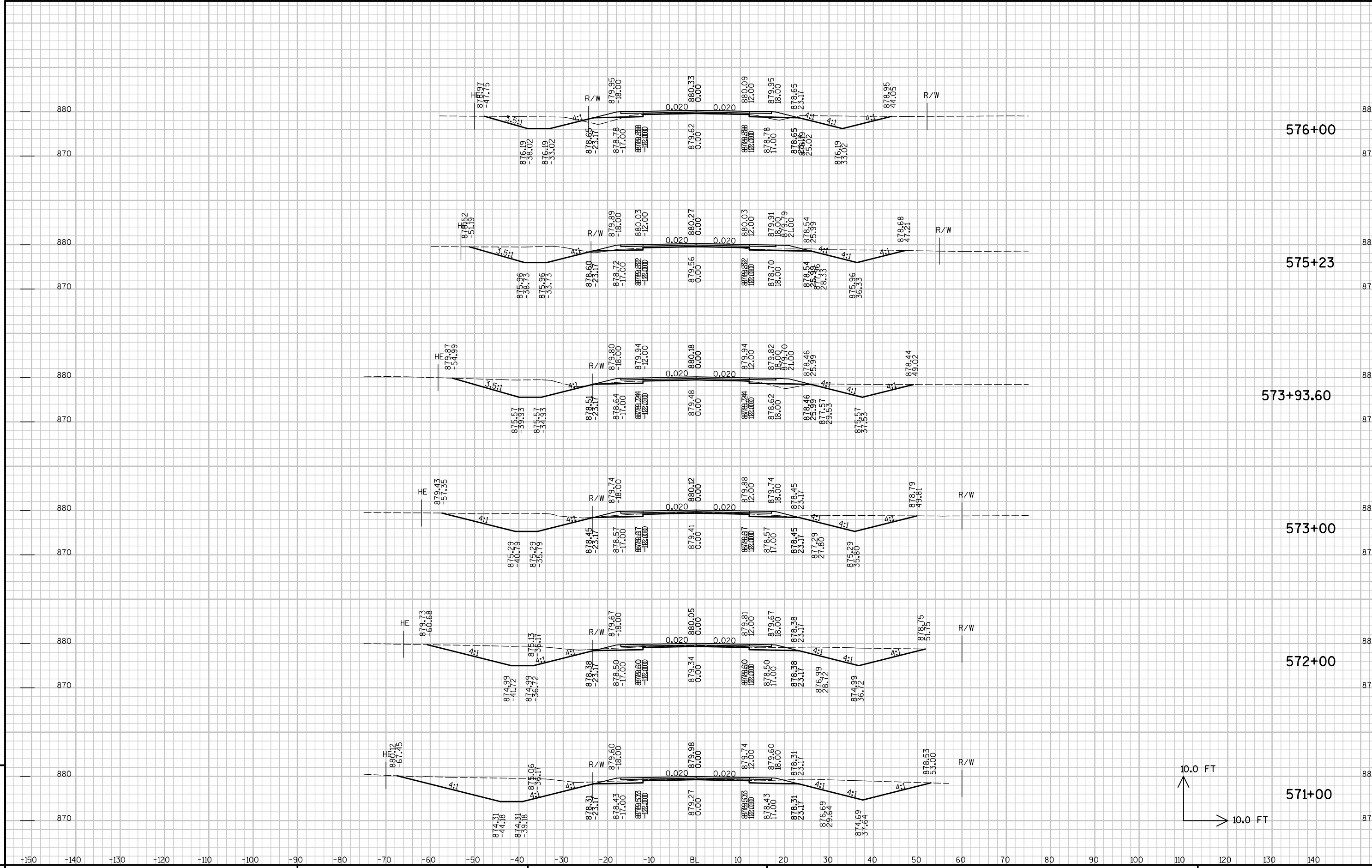

9

9

PROJECT NO : 6355-00-74 HWY : CTH Z COUNTY : ADAMS CROSS SECTIONS - CTH Z SHEET NO:

FILE NAME : X:\AEVA\ADAMC\157311\5-final-dsgr\51-drawings\CAD\cad\XBCTH2501-653.dgn PLOT TIME : 7:36:44 AM PLOT DATE : 2/9/2021 PLOT BY : SEH INC PLOT NAME : PLOT SCALE : Invalid expression

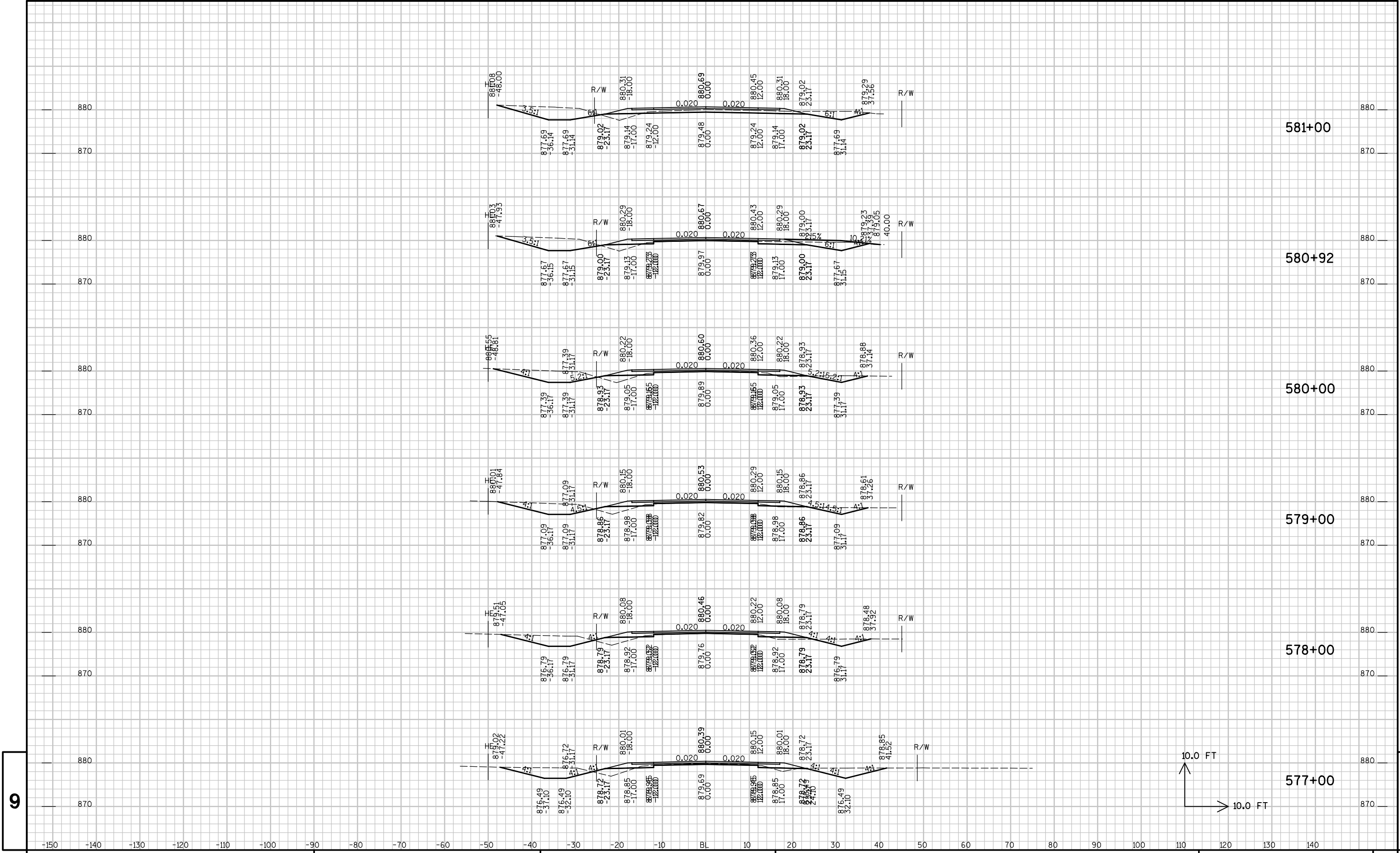

PROJECT NO : 6355-00-74

HWY : CTH Z

COUNTY : ADAMS

CROSS SECTIONS - CTH Z

SHEET NO:

E

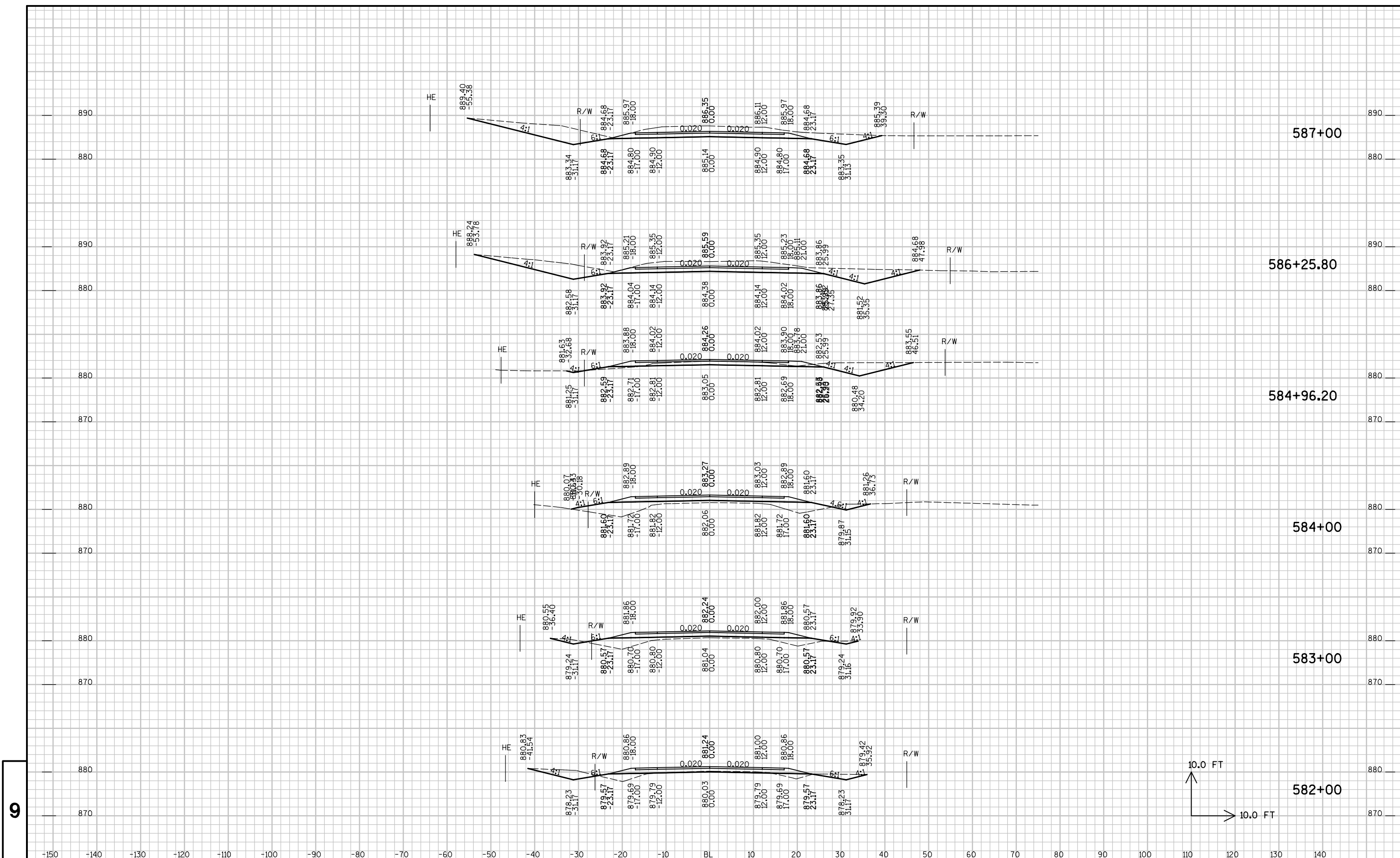

PROJECT NO : 6355-00-74

HWY : CTH Z

COUNTY : ADAMS

CROSS SECTIONS - CTH Z

SHEET NO:

9

9

E

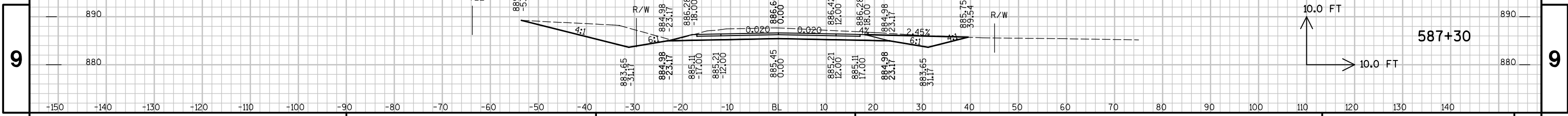
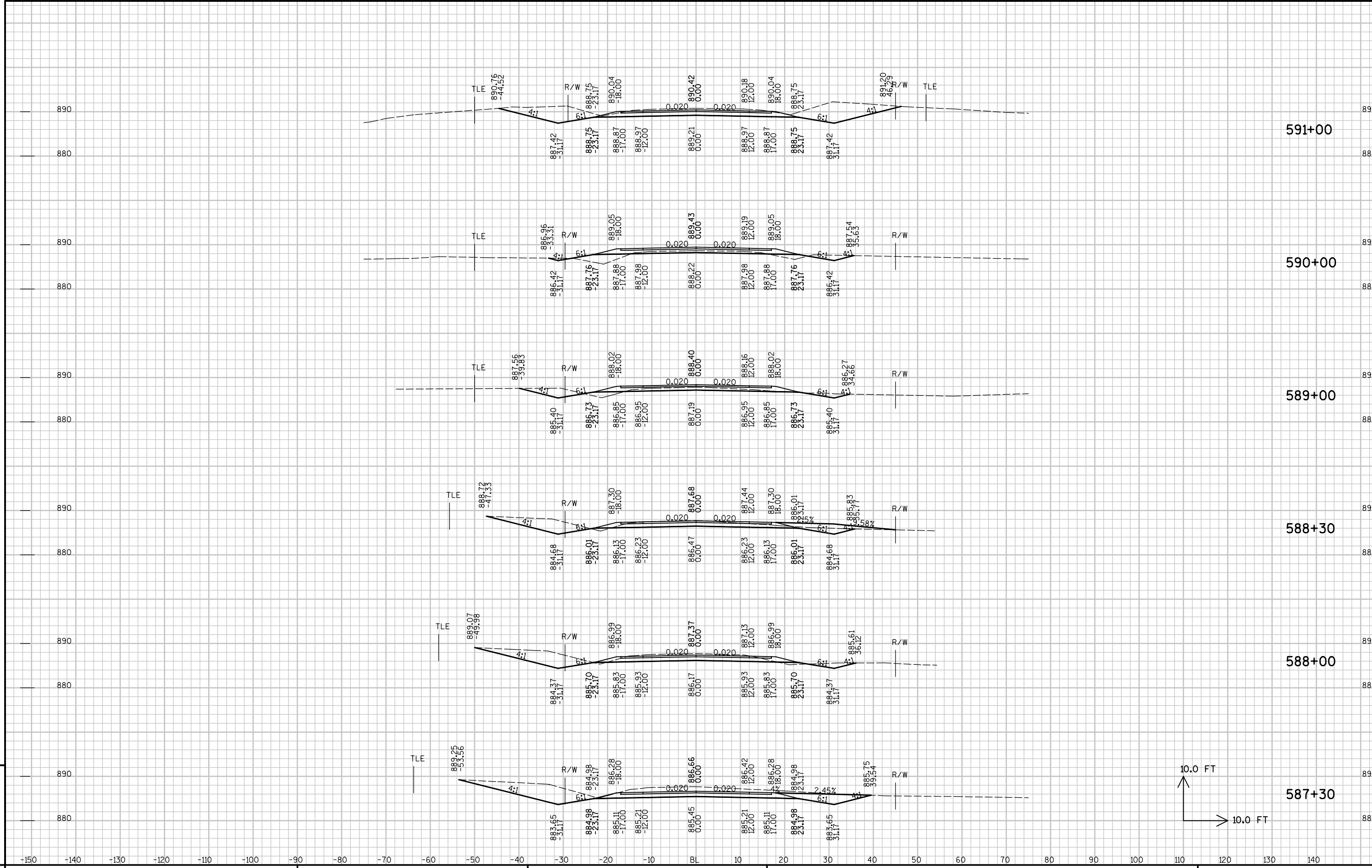

PROJECT NO : 6355-00-74 HWY : CTH Z COUNTY : ADAMS CROSS SECTIONS - CTH Z SHEET NO: E

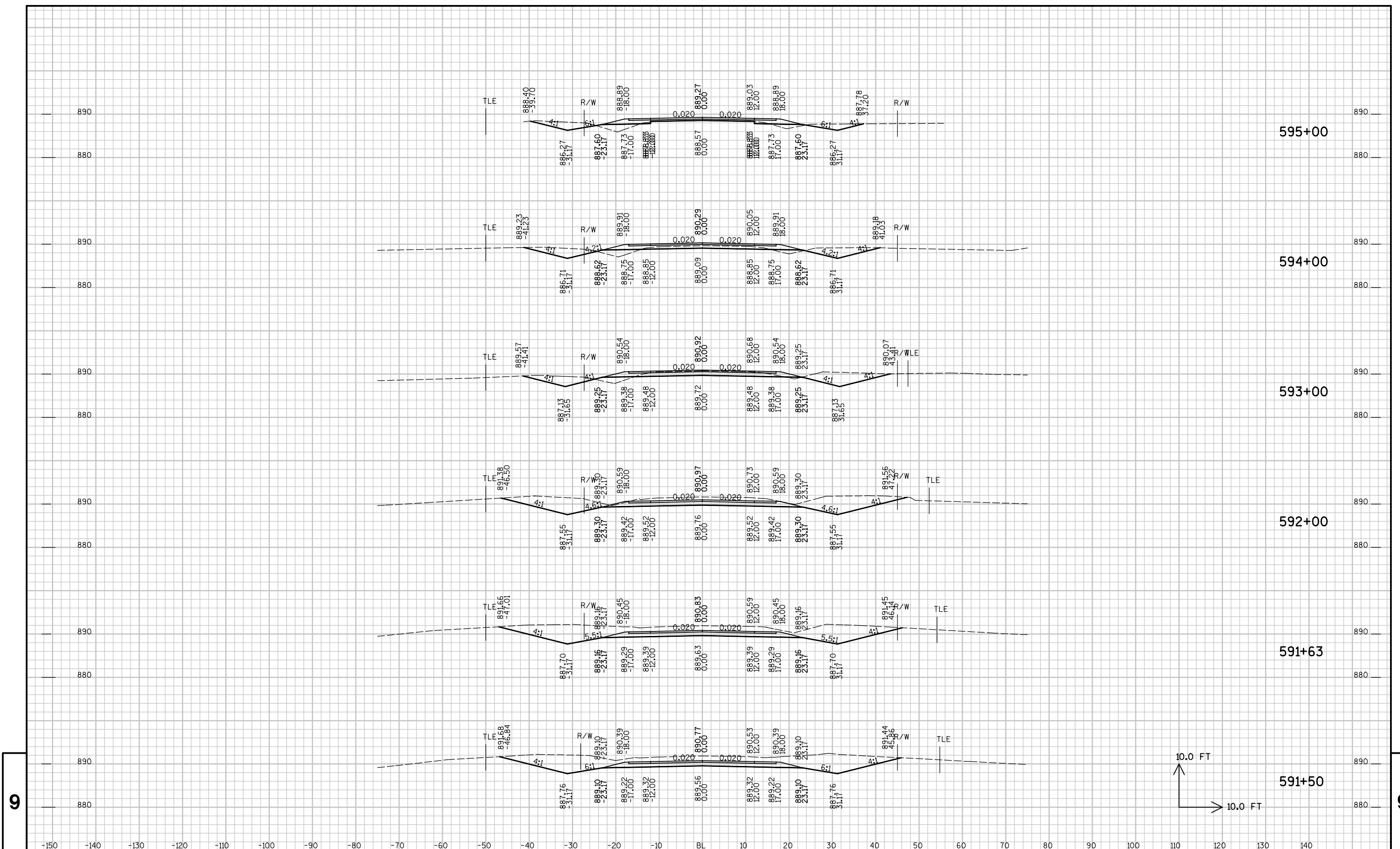

PROJECT NO : 6355-00-74

HWY : CTH Z

COUNTY : ADAMS

CROSS SECTIONS - CTH Z

SHEET NO:

E

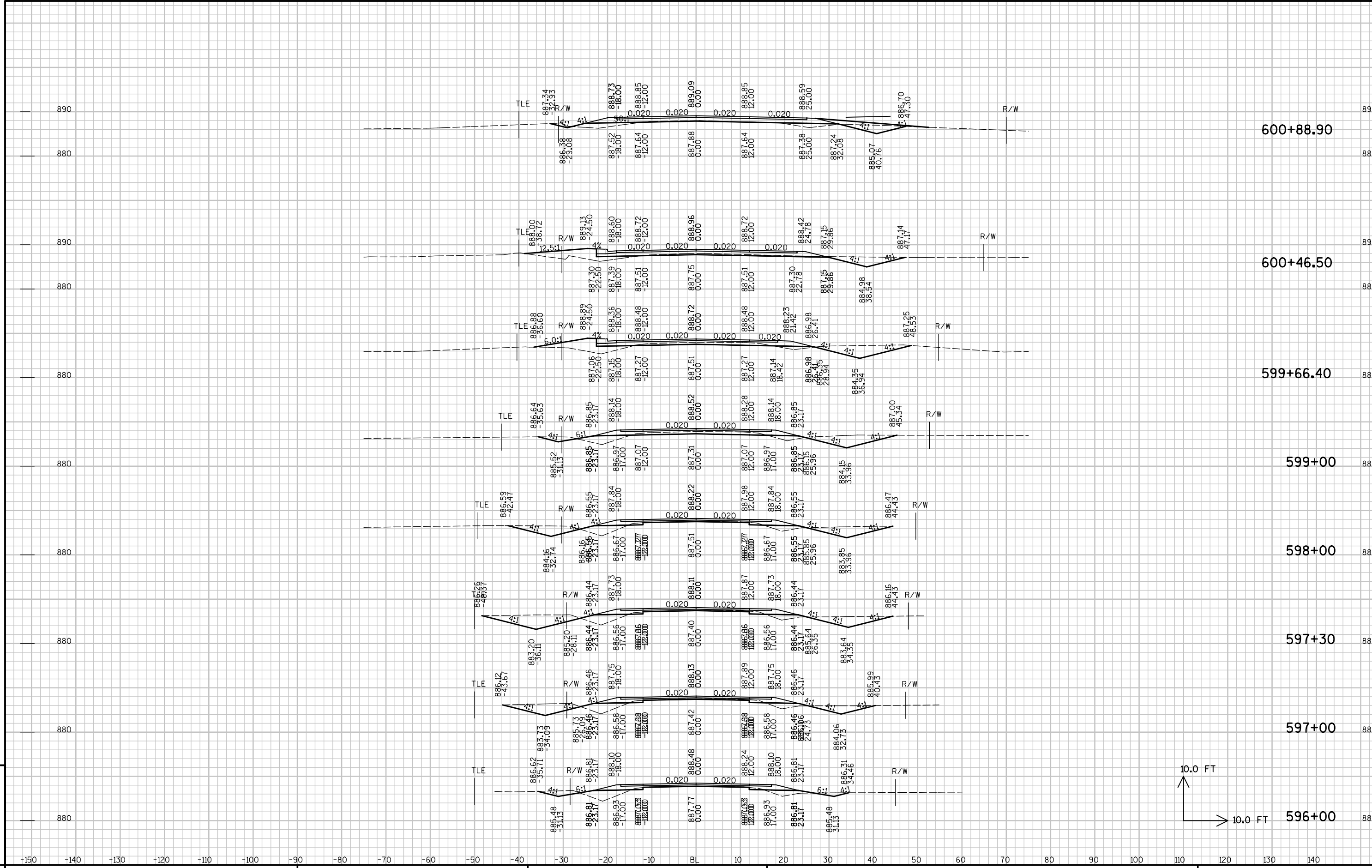

PROJECT NO : 6355-00-74 HWY : CTH Z COUNTY : ADAMS CROSS SECTIONS - CTH Z SHEET NO:

FILE NAME : X:\AE\ADAMC\157311\5-final-dsgr\51-drawings\CAD\load\XBCTH2501-653.dgn PLOT TIME : 7:37:19 AM PLOT DATE : 2/9/2021 PLOT BY : SEH INC PLOT NAME : PLOT SCALE : Invalid expression

9

9

E

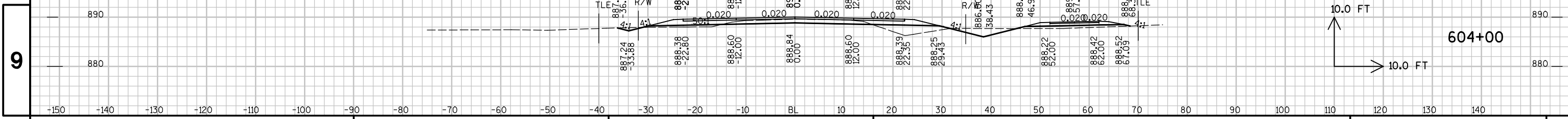
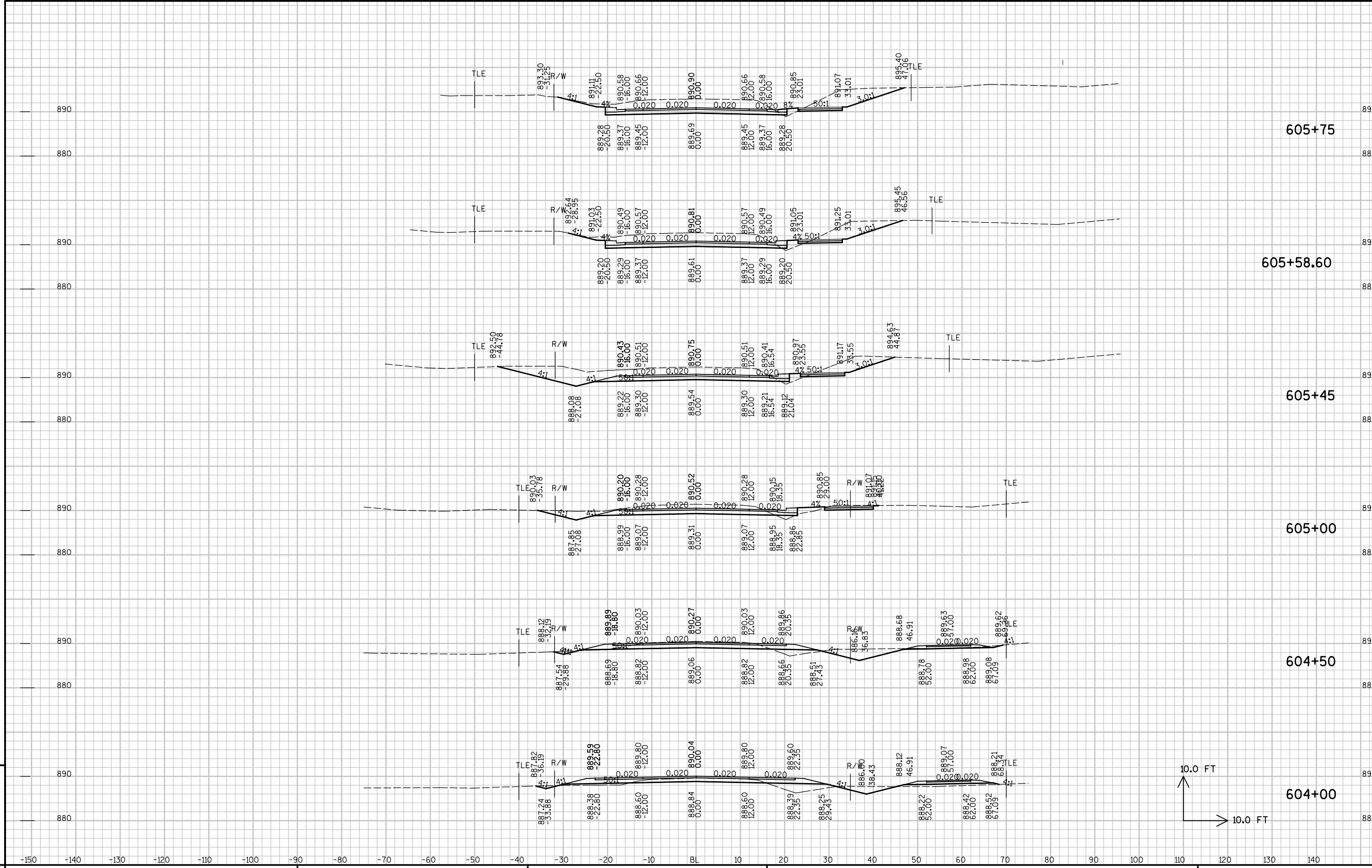

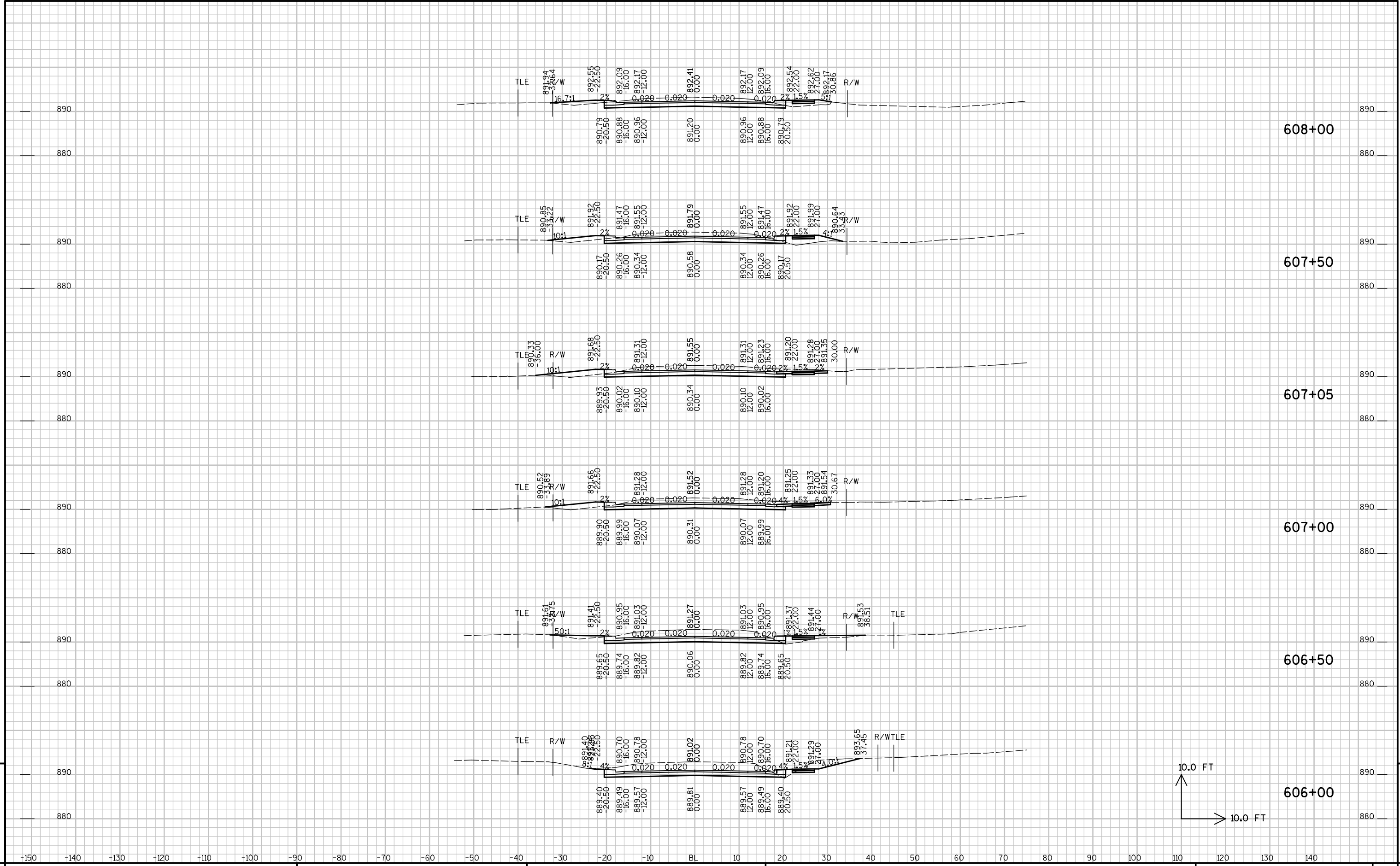

9

9

PROJECT NO : 6355-00-74 HWY : CTH Z COUNTY : ADAMS CROSS SECTIONS - CTH Z SHEET NO: E

FILE NAME : X:\AE\ADAMC\157311\5-final-dsgr\51-drawings\CAD\cad\XBCTHZ501-653.dgn PLOT TIME : 7:37:21 AM PLOT DATE : 2/9/2021 PLOT BY : SEH INC PLOT NAME : PLOT SCALE : Invalid expression

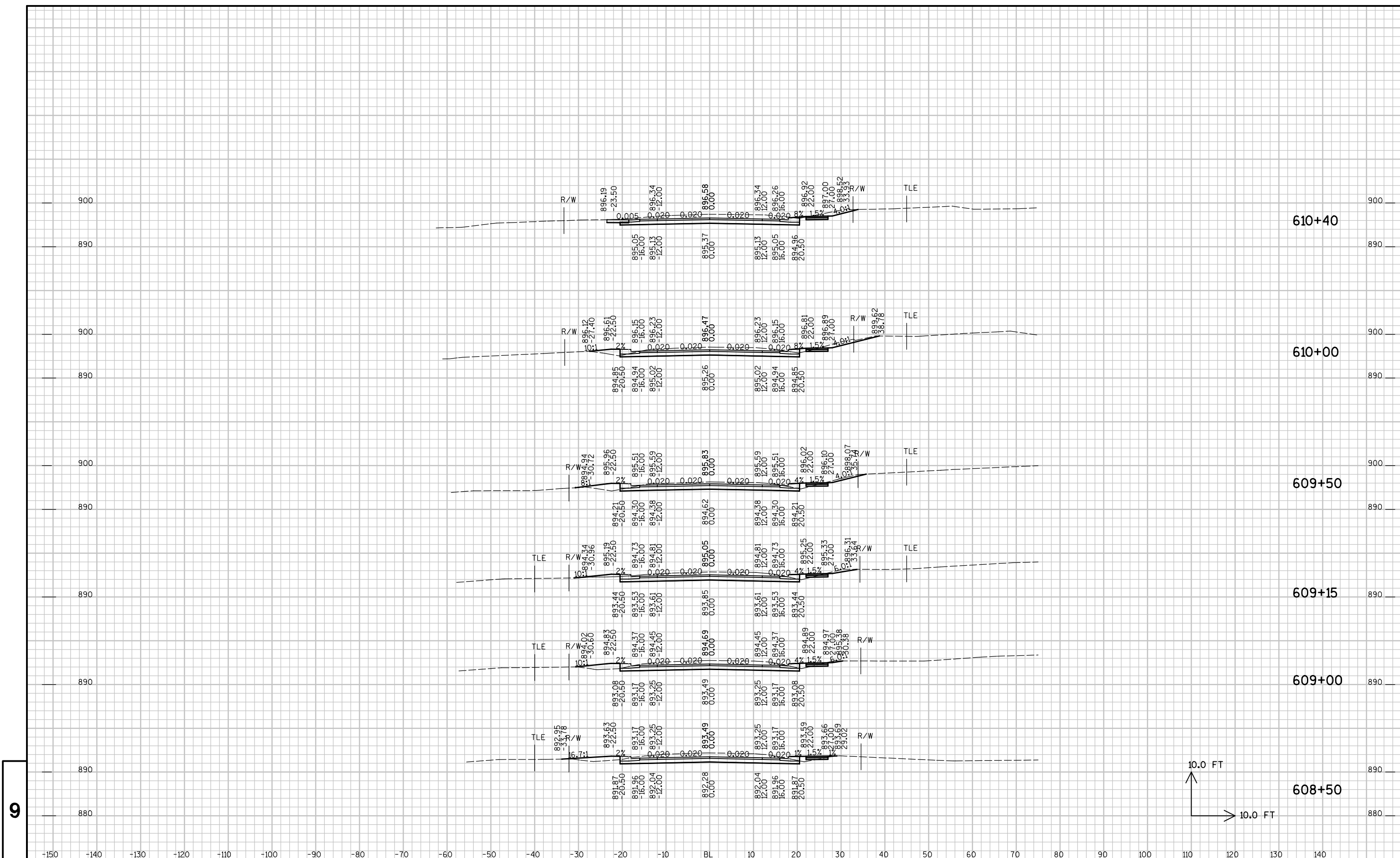

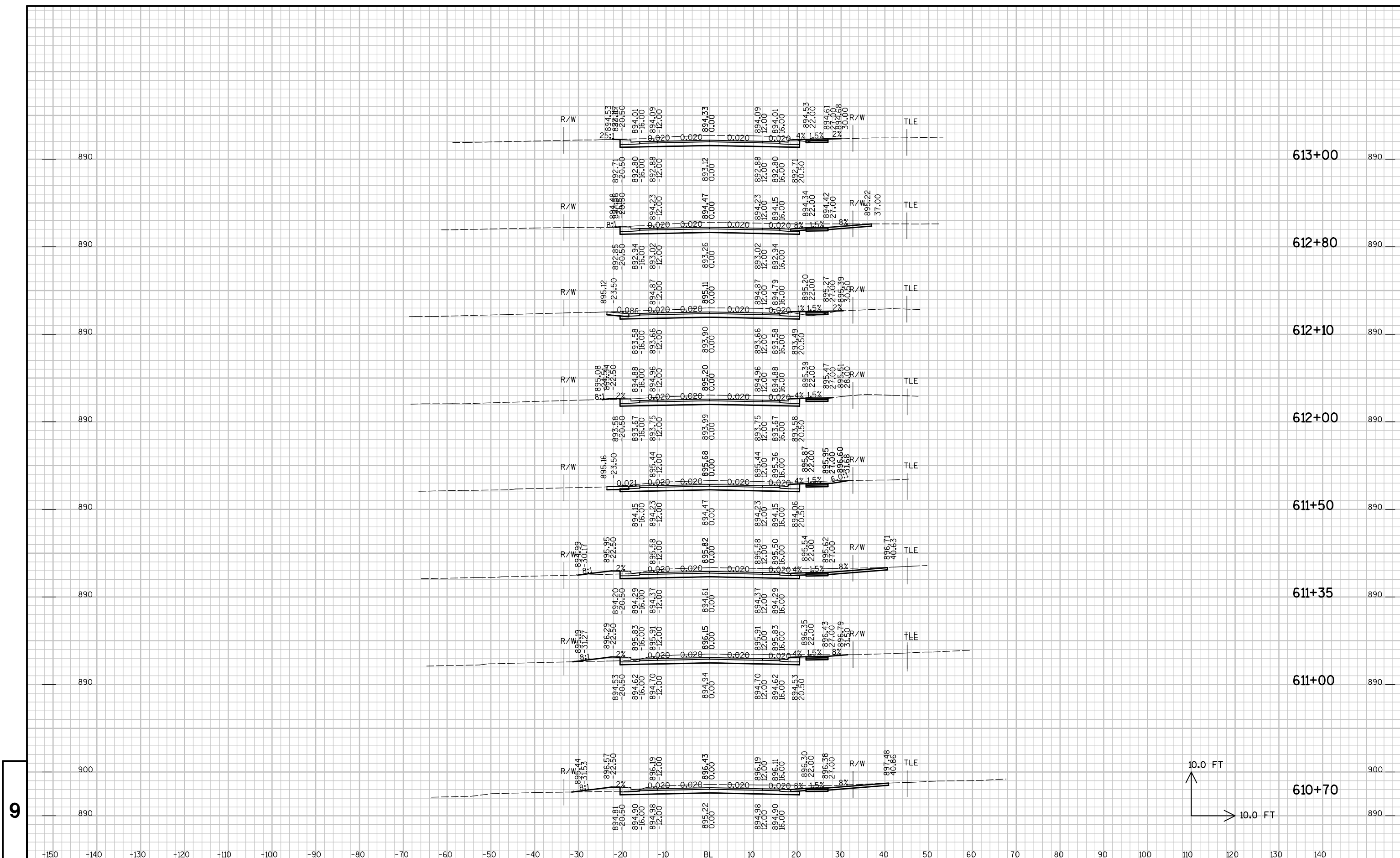

9

9

PROJECT NO : 6355-00-74 HWY : CTH Z COUNTY : ADAMS CROSS SECTIONS - CTH Z SHEET NO: E

FILE NAME : X:\AE\ADAMC\157311\5-final-dsgn\51-drawings\CAD\cad\XBCTH2501-653.dgn PLOT TIME : 7:37:23 AM PLOT DATE : 2/9/2021 PLOT BY : SEH INC PLOT NAME : PLOT SCALE : Invalid expression

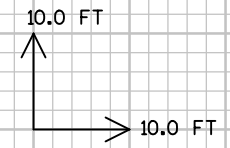

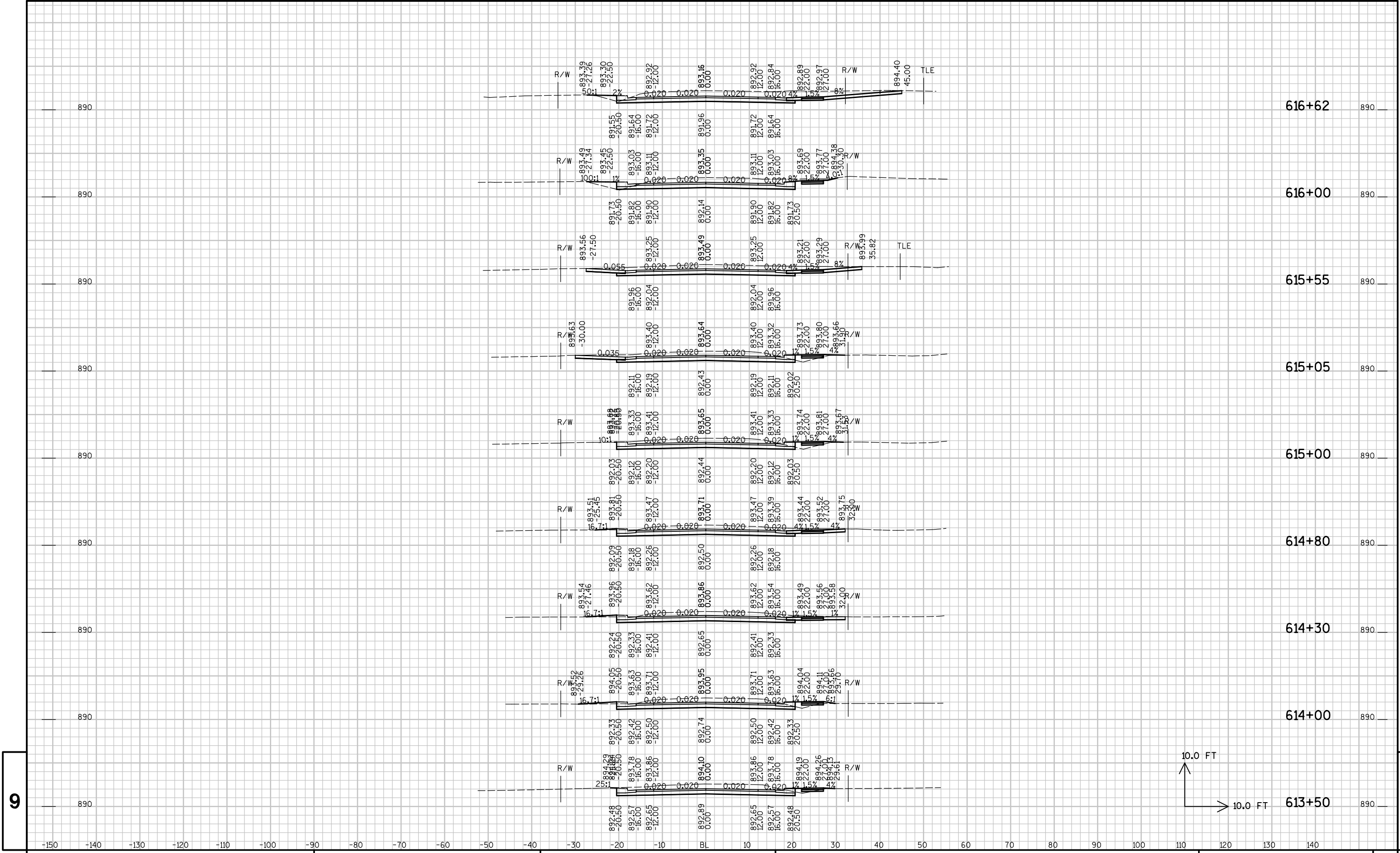

9

9

PROJECT NO : 6355-00-74 HWY : CTH Z COUNTY : ADAMS CROSS SECTIONS - CTH Z SHEET NO: E

FILE NAME : X:\AE\ADAMC\157311\5-f\ad1-dsgn\51-drawings\CAD\cad\XBCTH2501-653.dgn PLOT TIME : 7:37:24 AM PLOT DATE : 2/9/2021 PLOT BY : SEH INC PLOT NAME : PLOT SCALE : Invalid expression

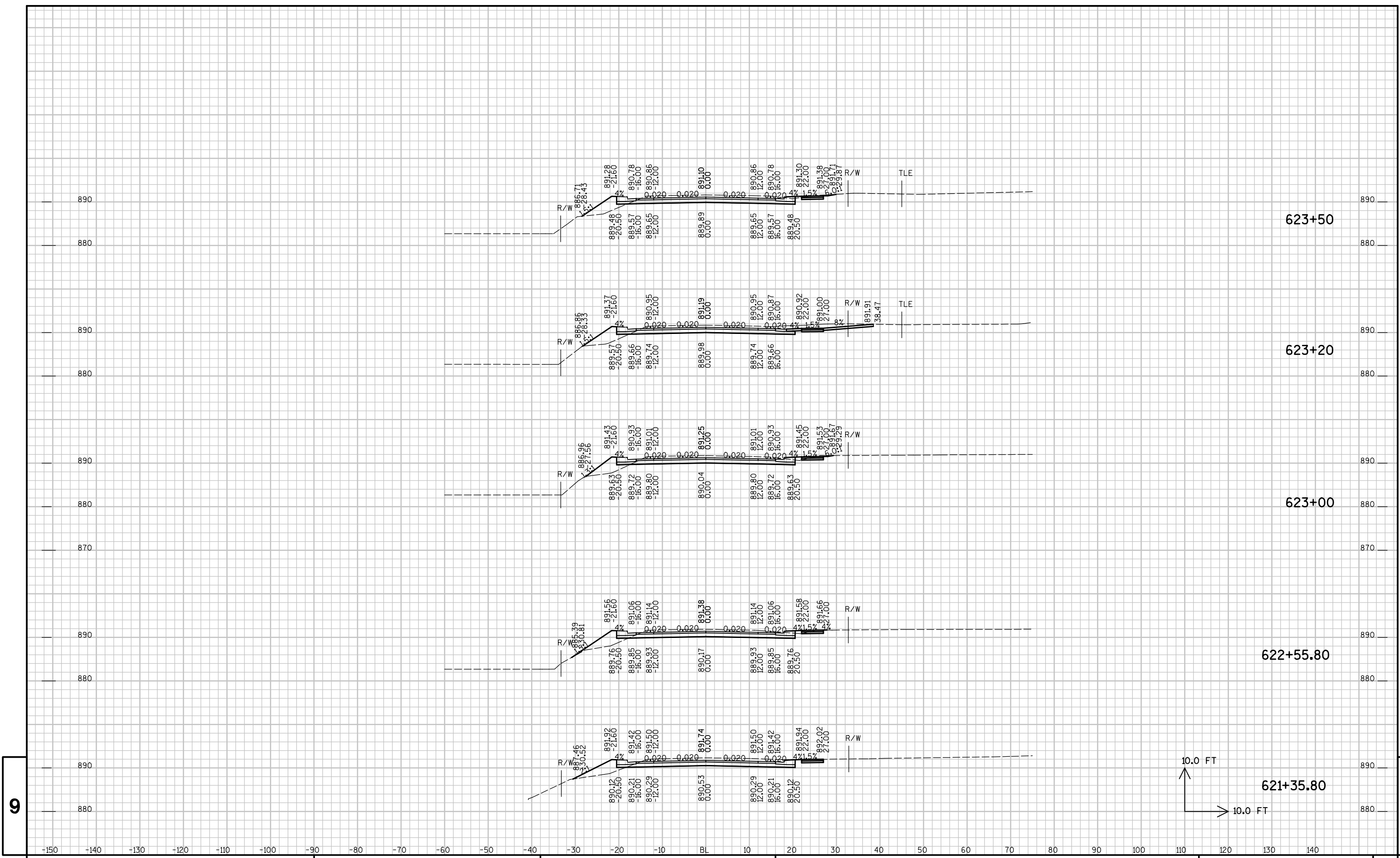

PROJECT NO : 6355-00-74

HWY : CTH Z

COUNTY : ADAMS

CROSS SECTIONS - CTH Z

SHEET NO:

9

9

E

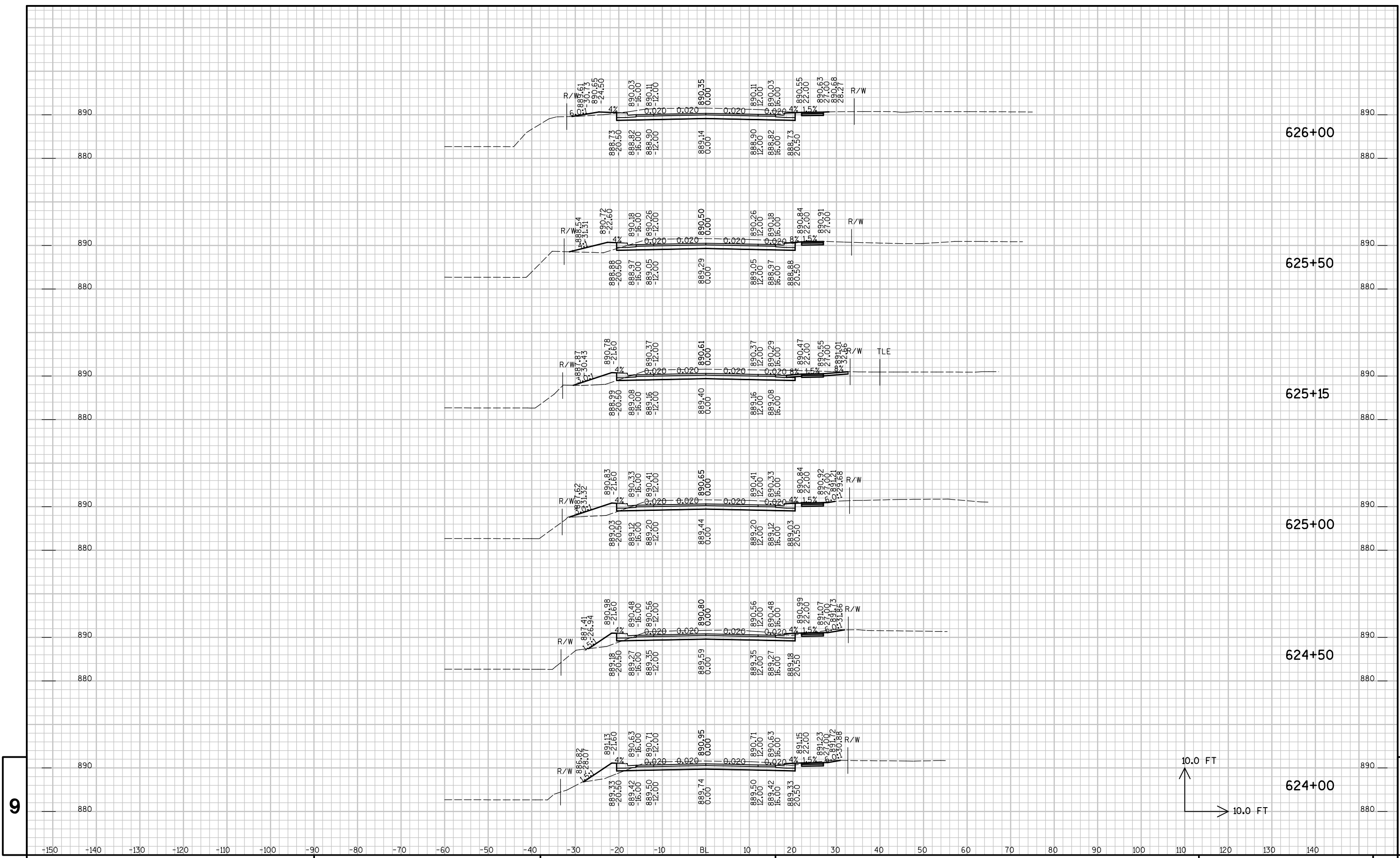

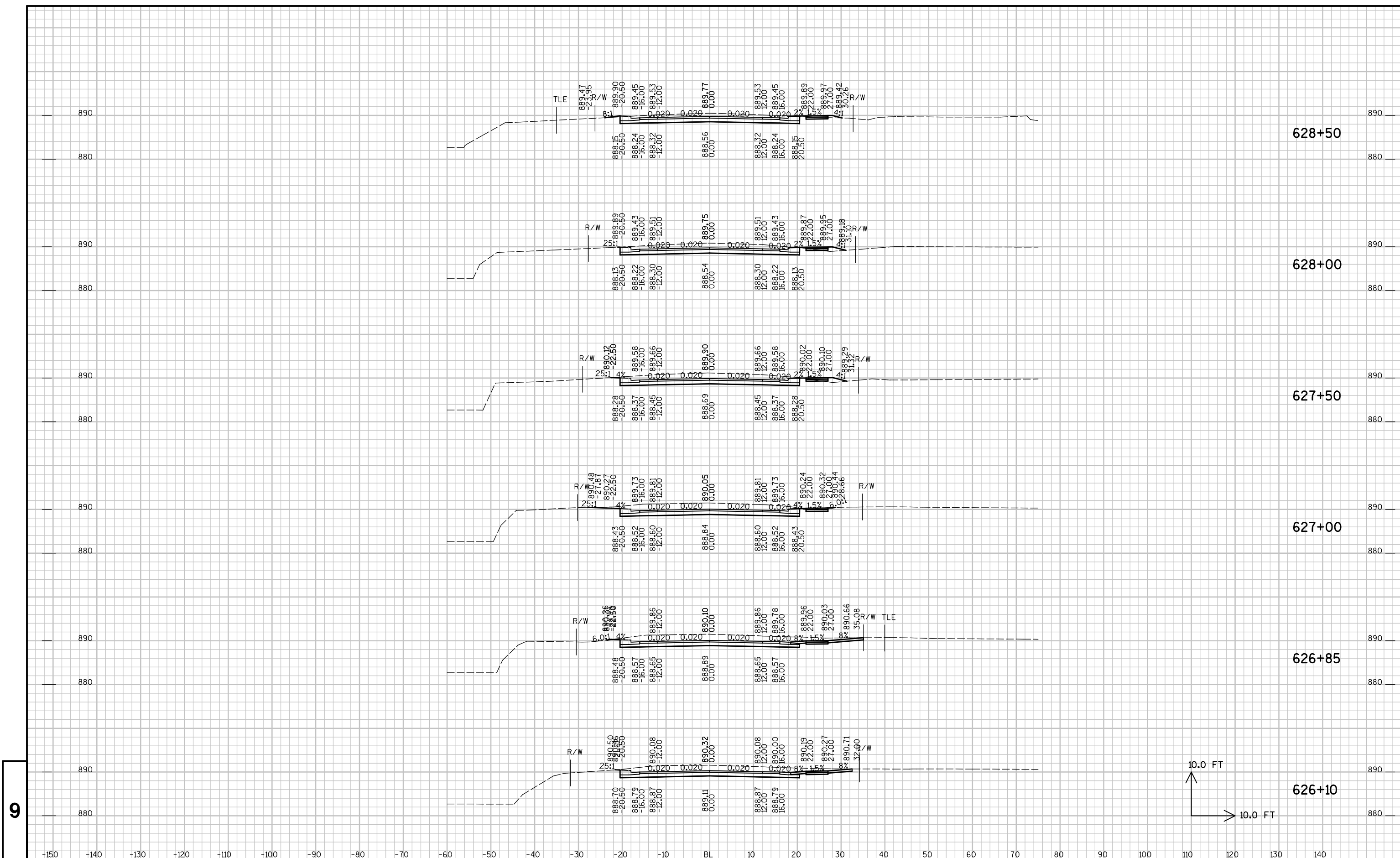

9

9

PROJECT NO : 6355-00-74	HWY : CTH Z	COUNTY : ADAMS	CROSS SECTIONS - CTH Z	SHEET NO:	E
-------------------------	-------------	----------------	------------------------	-----------	---

FILE NAME : X:\AE\ADAMC\157311\5-final-dsgn\51-drawings\CAD\cad\XBCTH2501-653.dgn PLOT TIME : 7:37:28 AM PLOT DATE : 2/9/2021 PLOT BY : SEH INC PLOT NAME : PLOT SCALE : Invalid expression

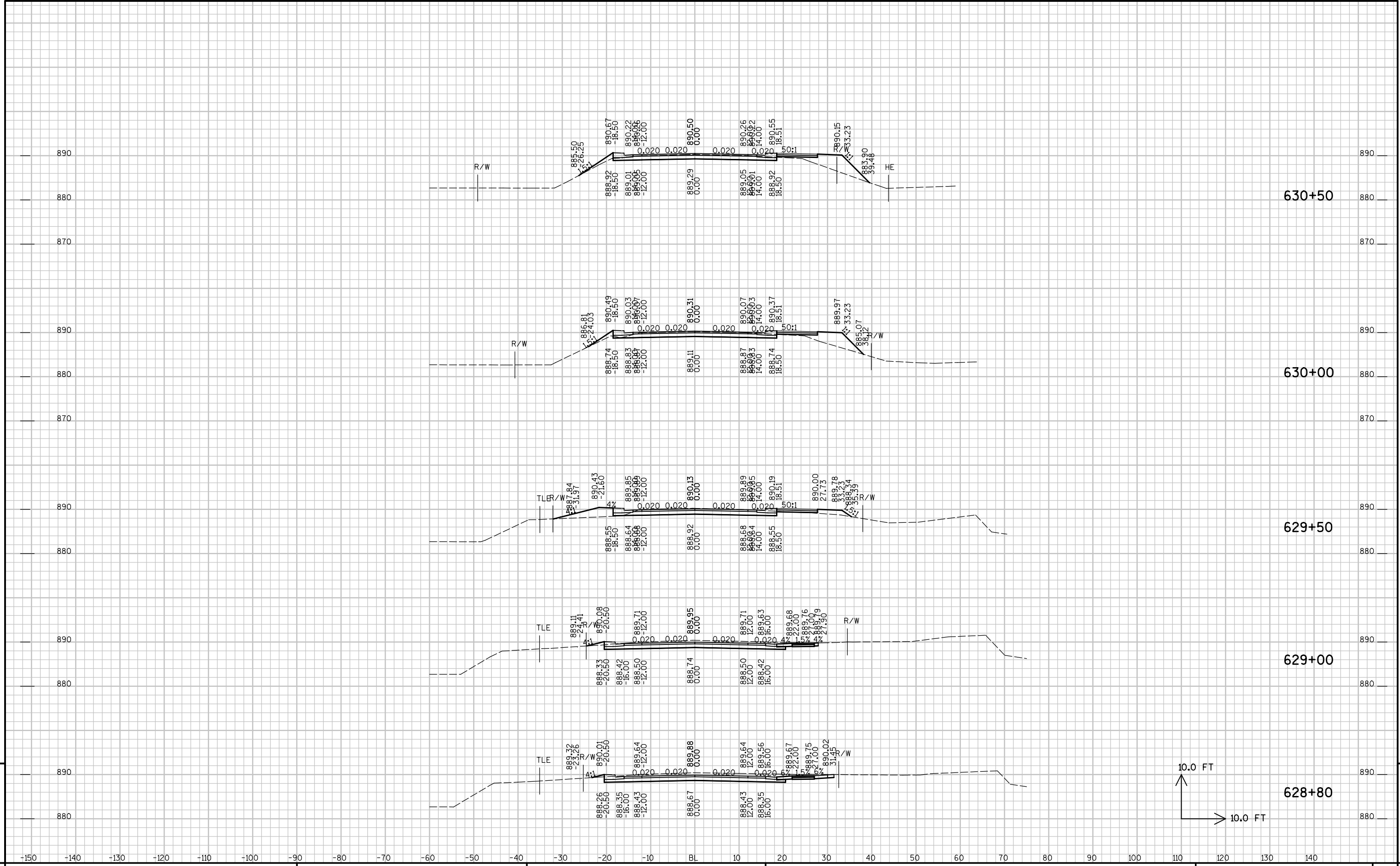

9

9

PROJECT NO : 6355-00-74	HWY : CTH Z	COUNTY : ADAMS	CROSS SECTIONS - CTH Z	SHEET NO:	E
-------------------------	-------------	----------------	------------------------	-----------	---

FILE NAME : X:\AE\ADAMC\157311\5-final-dsgn\51-drawings\CAD\cad\XBCTH2501-653.dgn PLOT TIME : 7:37:30 AM PLOT DATE : 2/9/2021 PLOT BY : SEH INC PLOT NAME : PLOT SCALE : Invalid expression

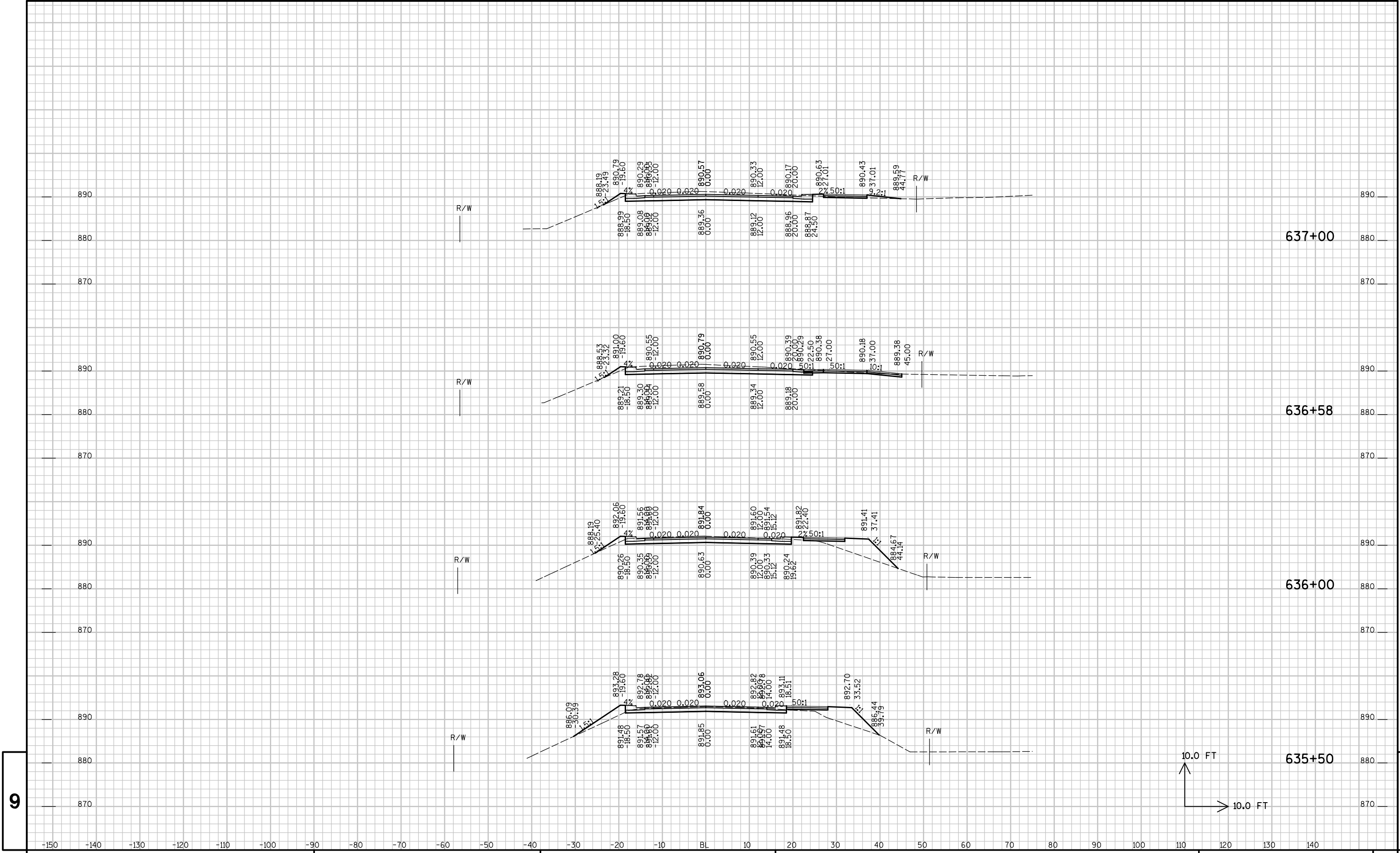

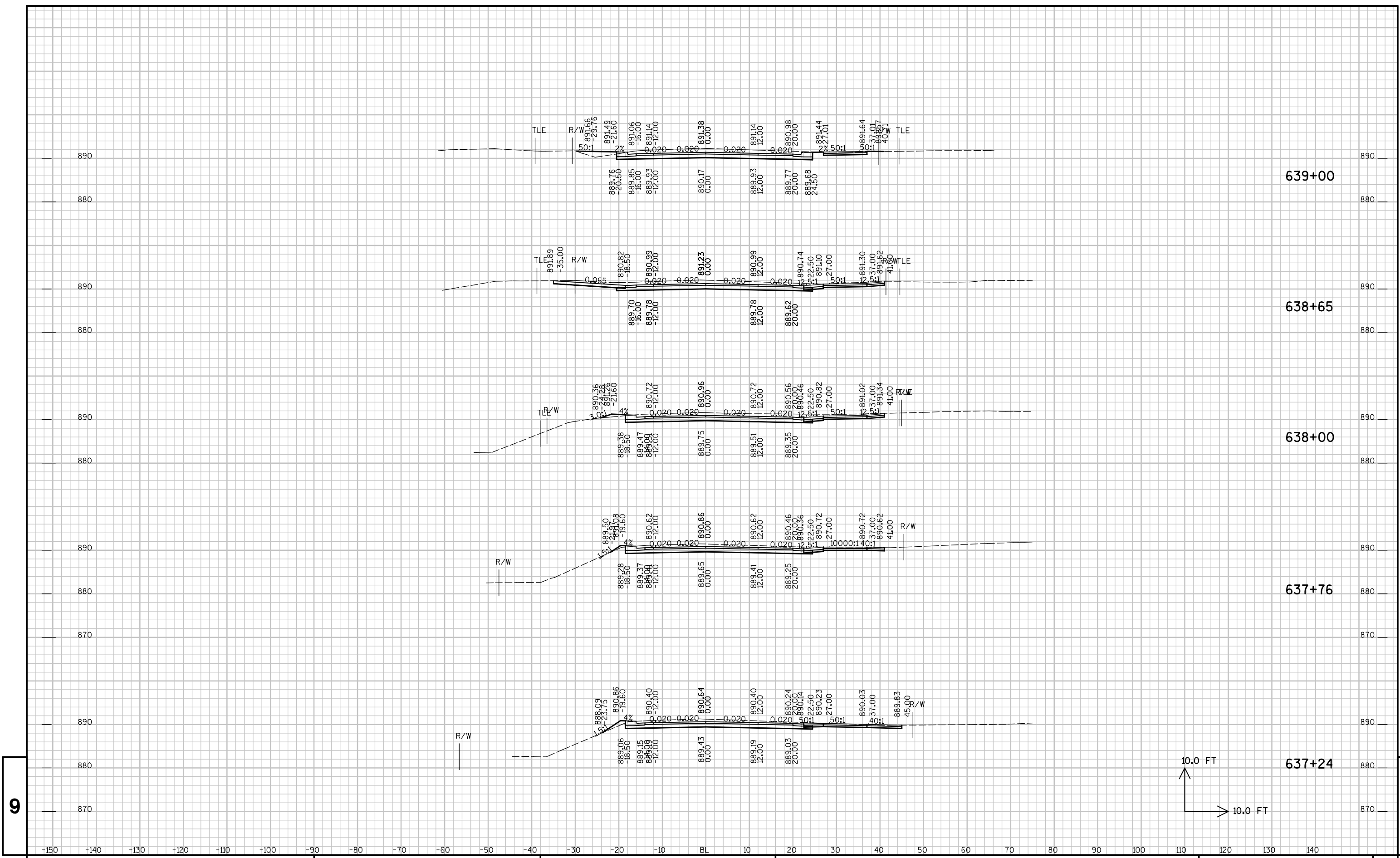

9

9

PROJECT NO : 6355-00-74 HWY : CTH Z COUNTY : ADAMS CROSS SECTIONS - CTH Z SHEET NO: E

FILE NAME : X:\AE\ADAMC\157311\5-final-dsgn\51-drawings\CAD\cad\XBCTHZ501-653.dgn PLOT TIME : 7:37:32 AM PLOT DATE : 2/9/2021 PLOT BY : SEH INC PLOT NAME : PLOT SCALE : Invalid expression

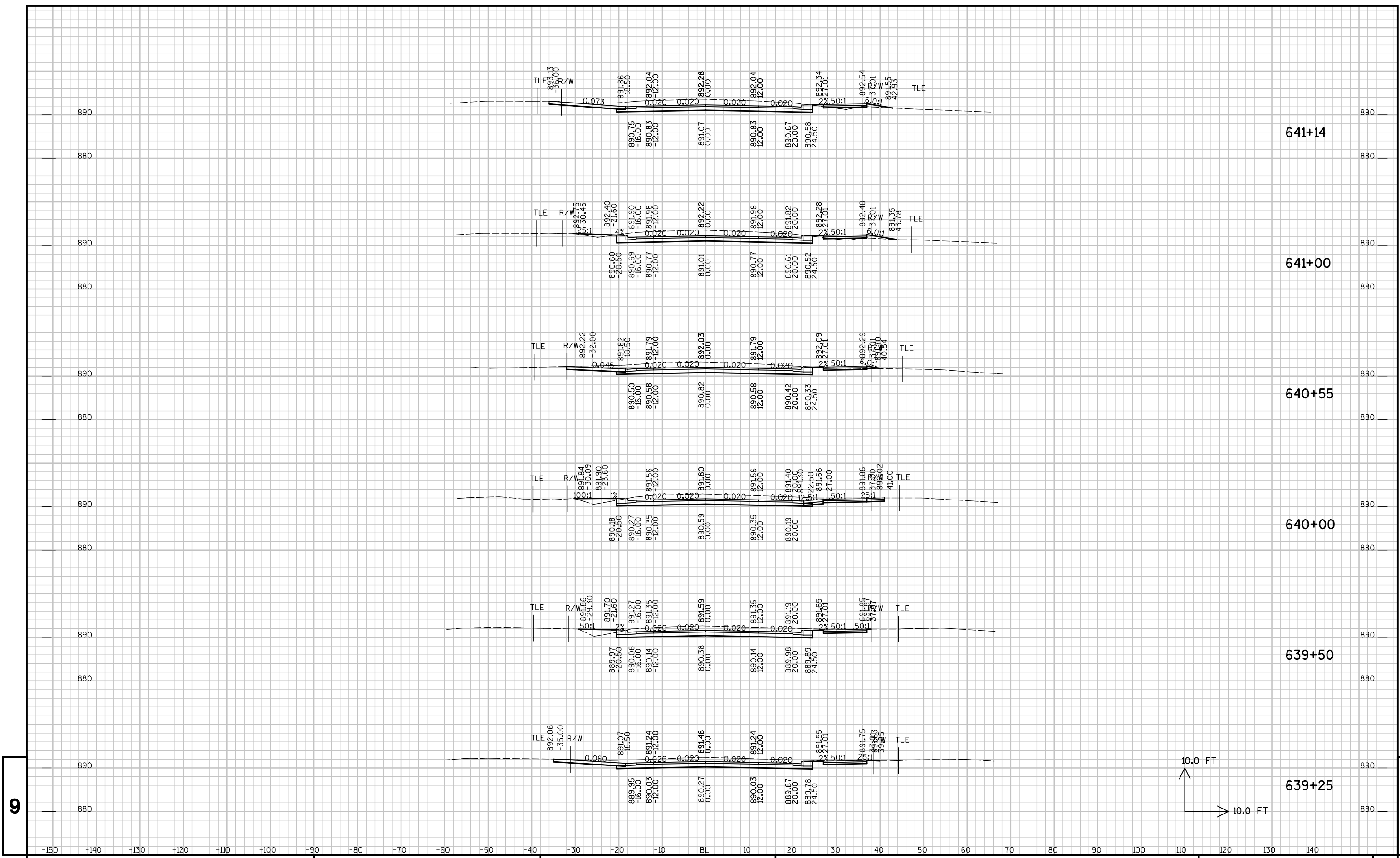

9

9

PROJECT NO : 6355-00-74 HWY : CTH Z COUNTY : ADAMS CROSS SECTIONS - CTH Z SHEET NO: E

FILE NAME : X:\AE\A\ADAMC\157311\5-final-dsgn\51-drawings\CAD\oad\XBCTHZ501-653.dgn PLOT TIME : 7:37:33 AM PLOT DATE : 2/9/2021 PLOT BY : SEH INC PLOT NAME : PLOT SCALE : Invalid expression

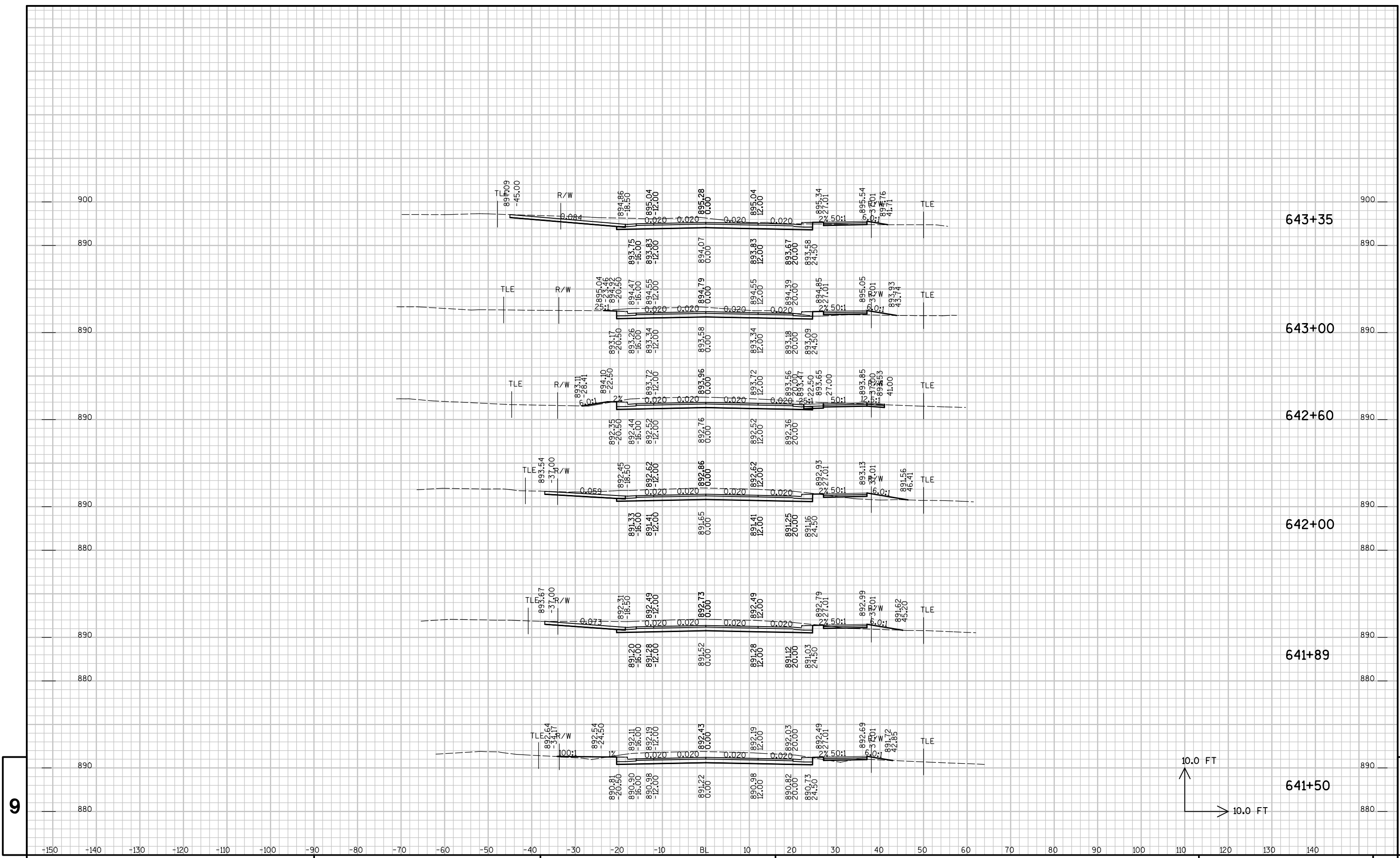

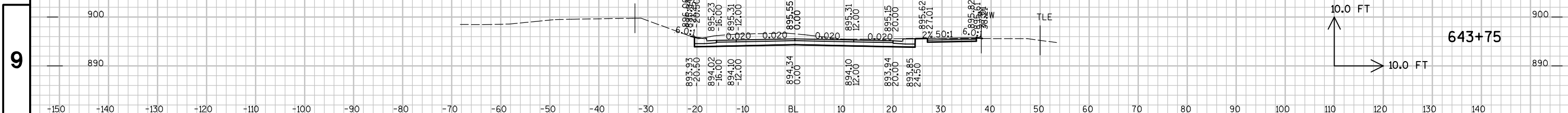
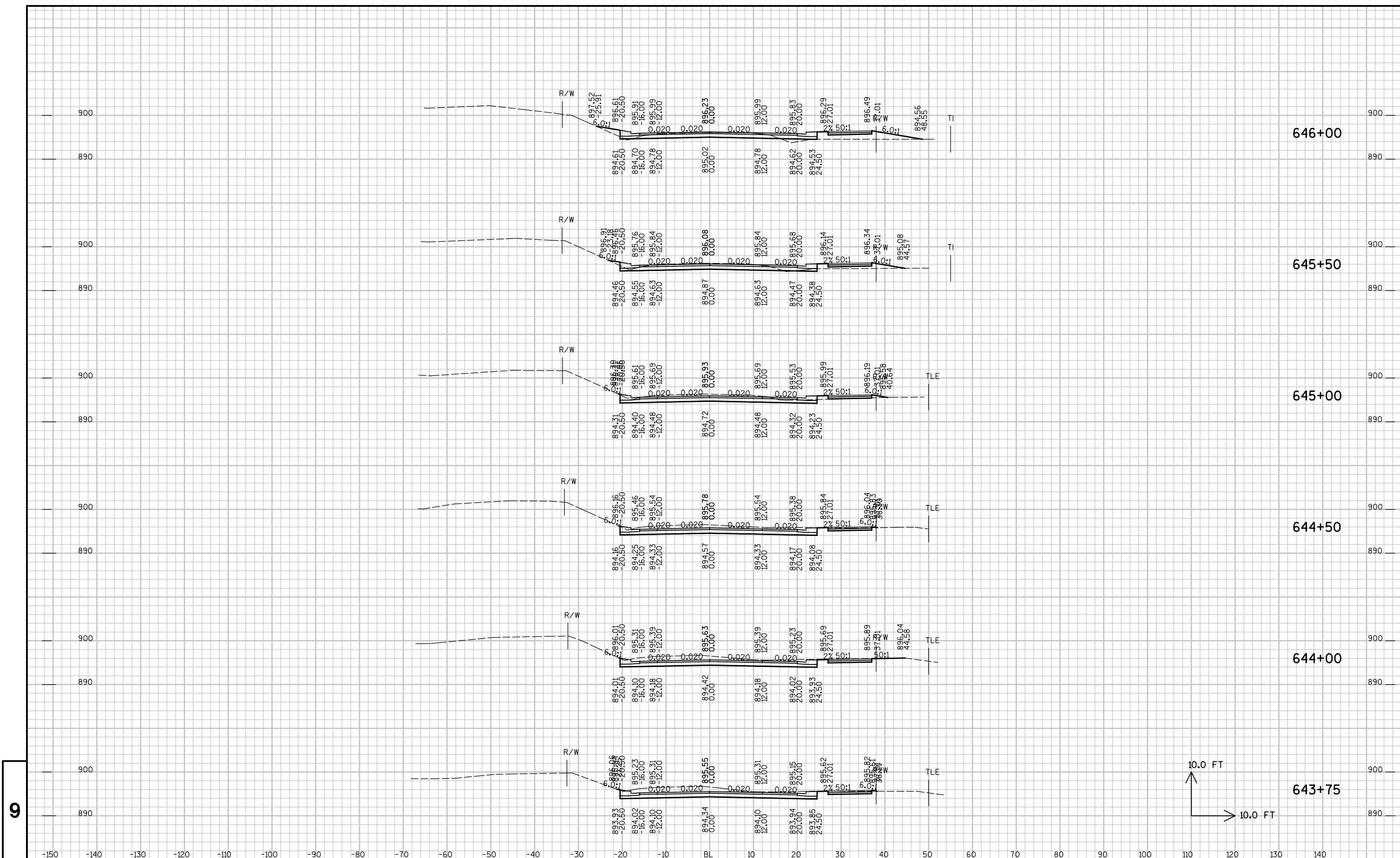

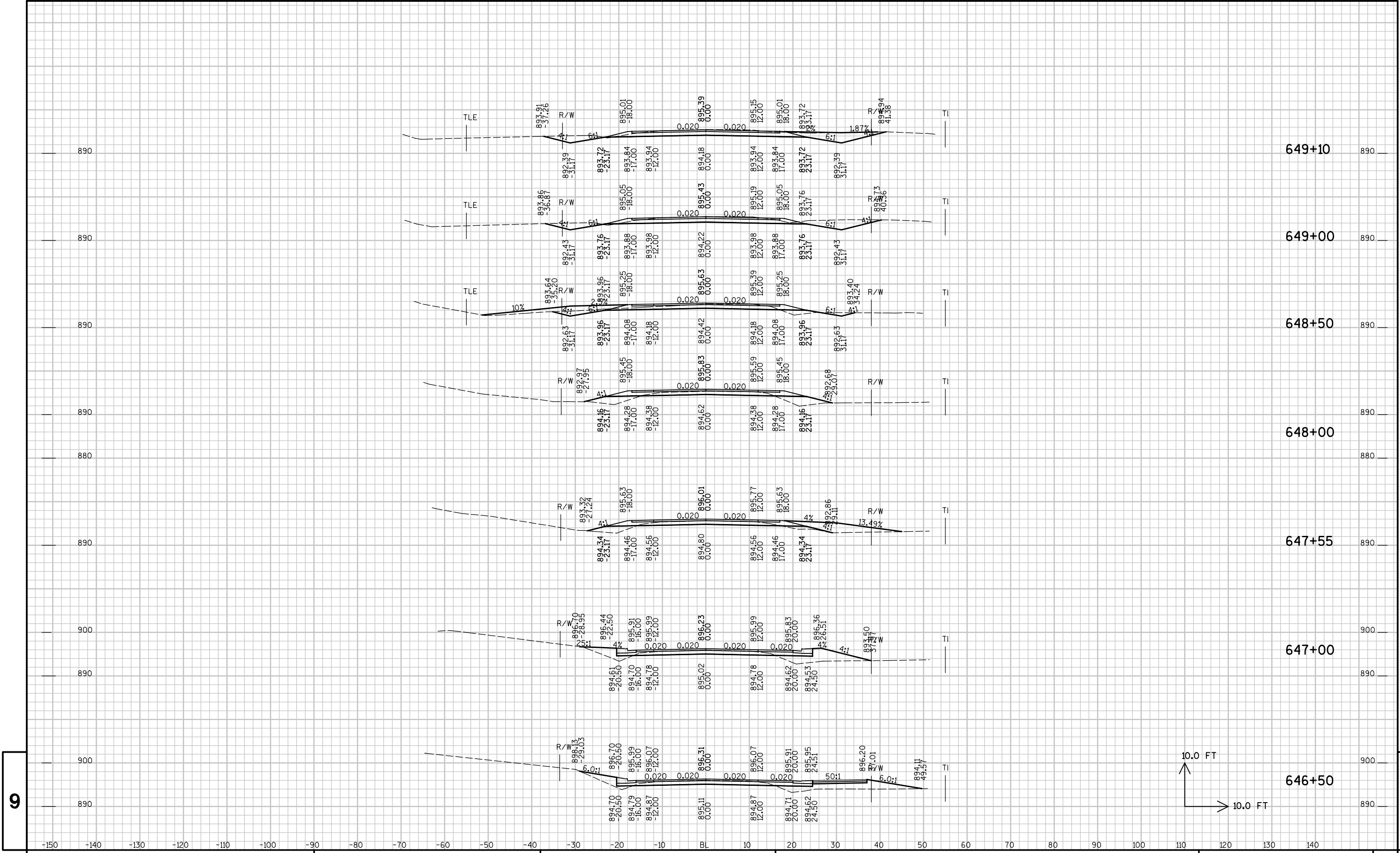

9

9

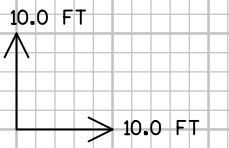

PROJECT NO : 6355-00-74 HWY : CTH Z COUNTY : ADAMS CROSS SECTIONS - CTH Z SHEET NO: E

FILE NAME : X:\AE\ADAMC\157311\5-final-dsgn\51-drawings\CAD\cad\XBCTH2501-653.dgn PLOT TIME : 7:37:36 AM PLOT DATE : 2/9/2021 PLOT BY : SEH INC PLOT NAME : PLOT SCALE : Invalid expression

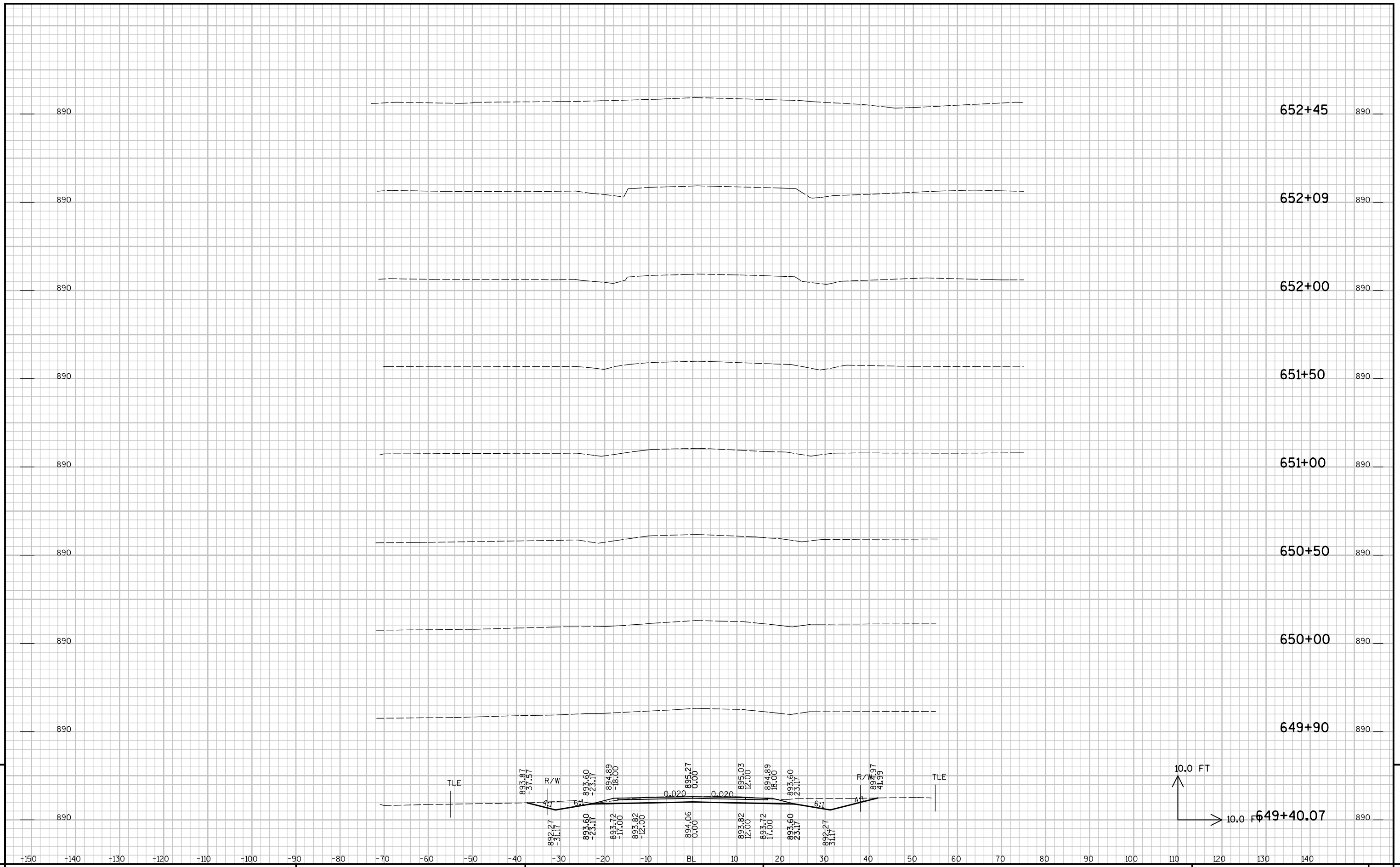

9

9

END CONSTRUCTION
STA 66+50.00

BEGIN CONSTRUCTION
STA 63+50.00

860

860

860

860

860

860

860

860

66+50

66+00

65+76

65+60

CTH Z LT & RT

PE LT

64+42

PE LT

64+22

PE LT

64+00

PE LT

63+50

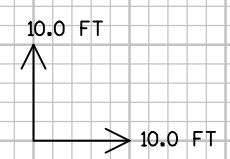

9

9

PROJECT NO : 6355-00-74 HWY : CTH Z COUNTY : ADAMS CROSS SECTIONS - EDGEWOOD AVENUE SHEET NO: E

FILE NAME : X:\AE\ADAMC\157311\5-final-dsgn\51-drawings\CAD\cad\XB10edgewoodavenue.dgn PLOT TIME : 7:37:41 AM PLOT DATE : 2/9/2021 PLOT BY : SEH INC PLOT NAME : PLOT SCALE : Invalid expression

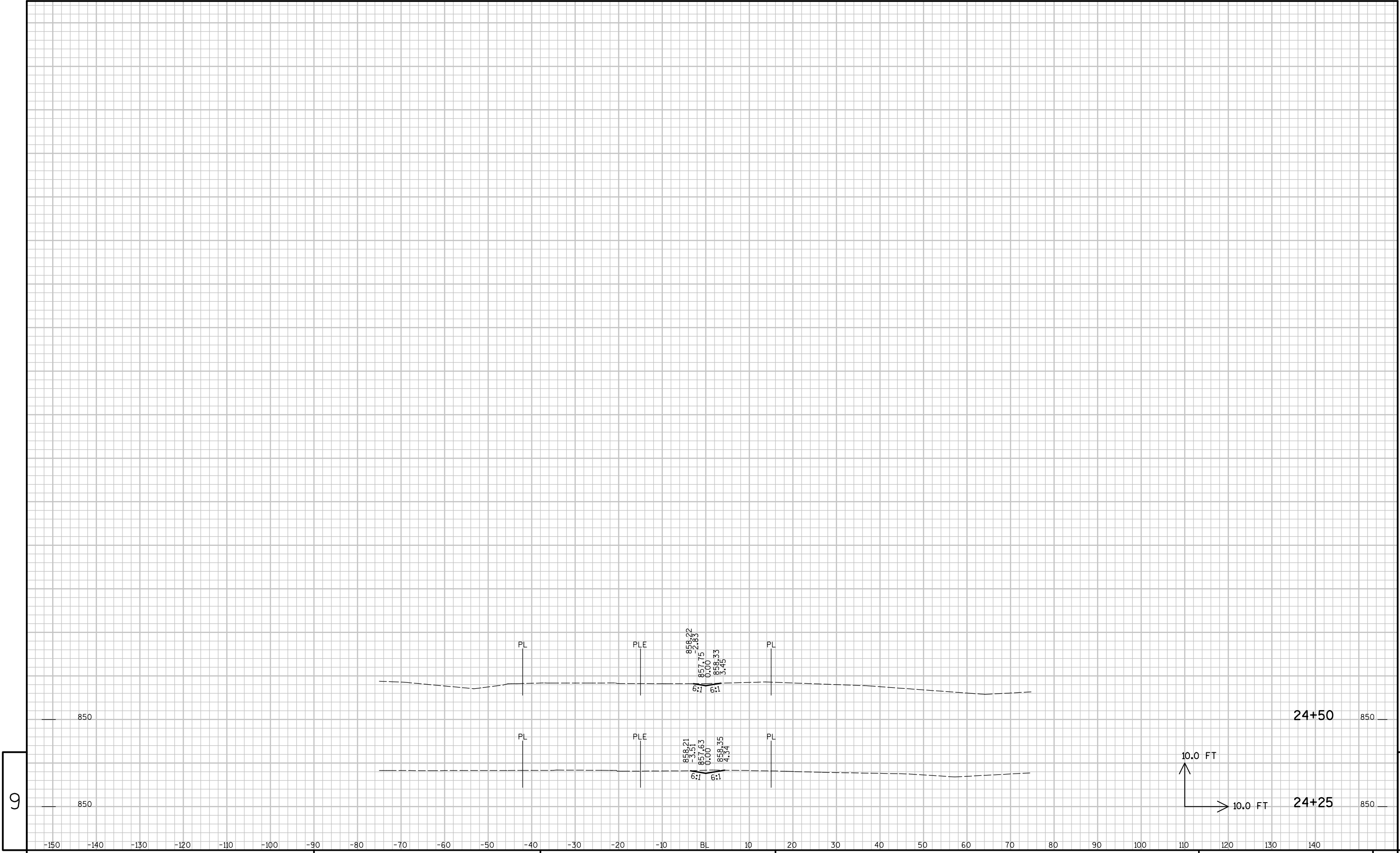

9

9

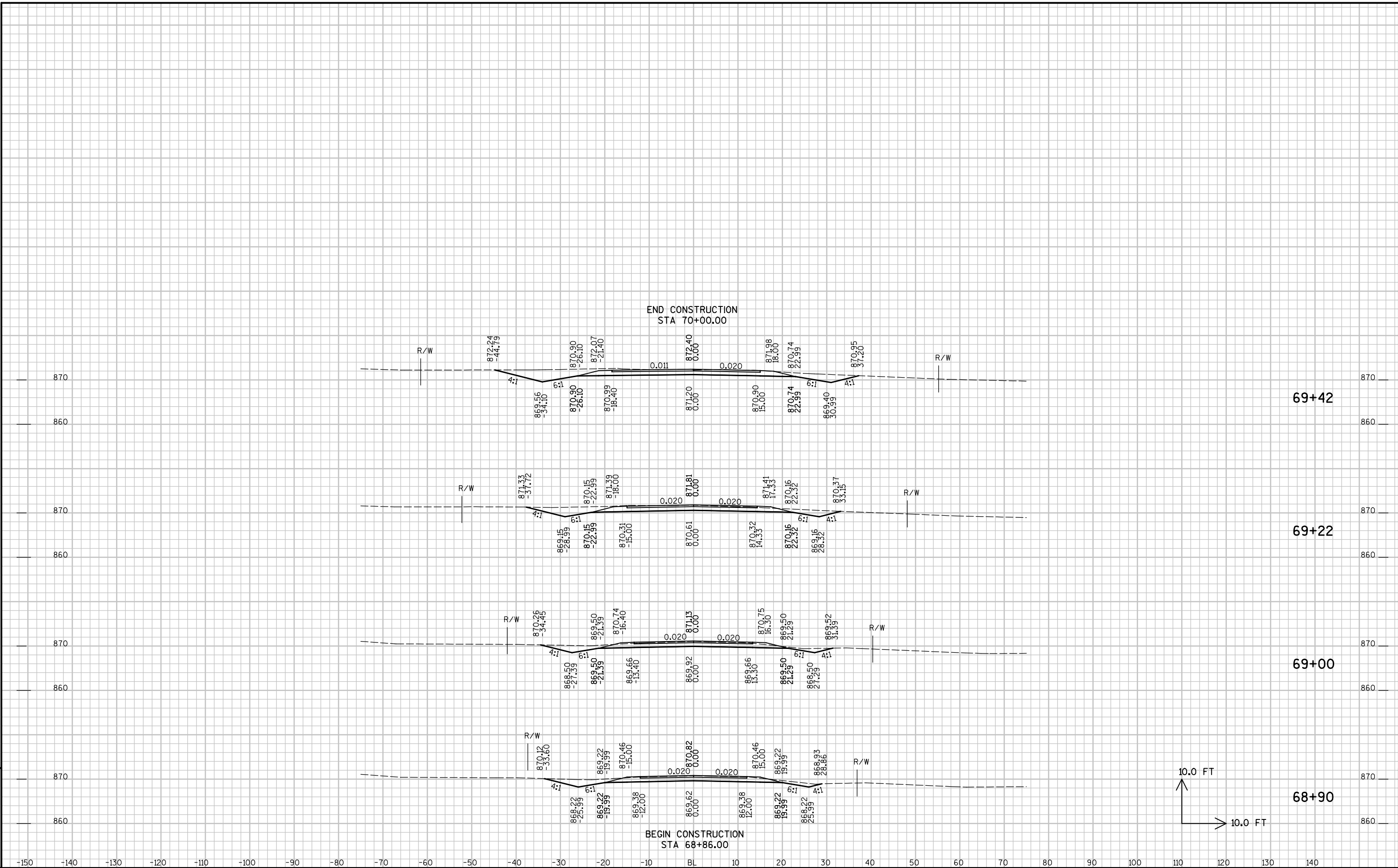

9

9

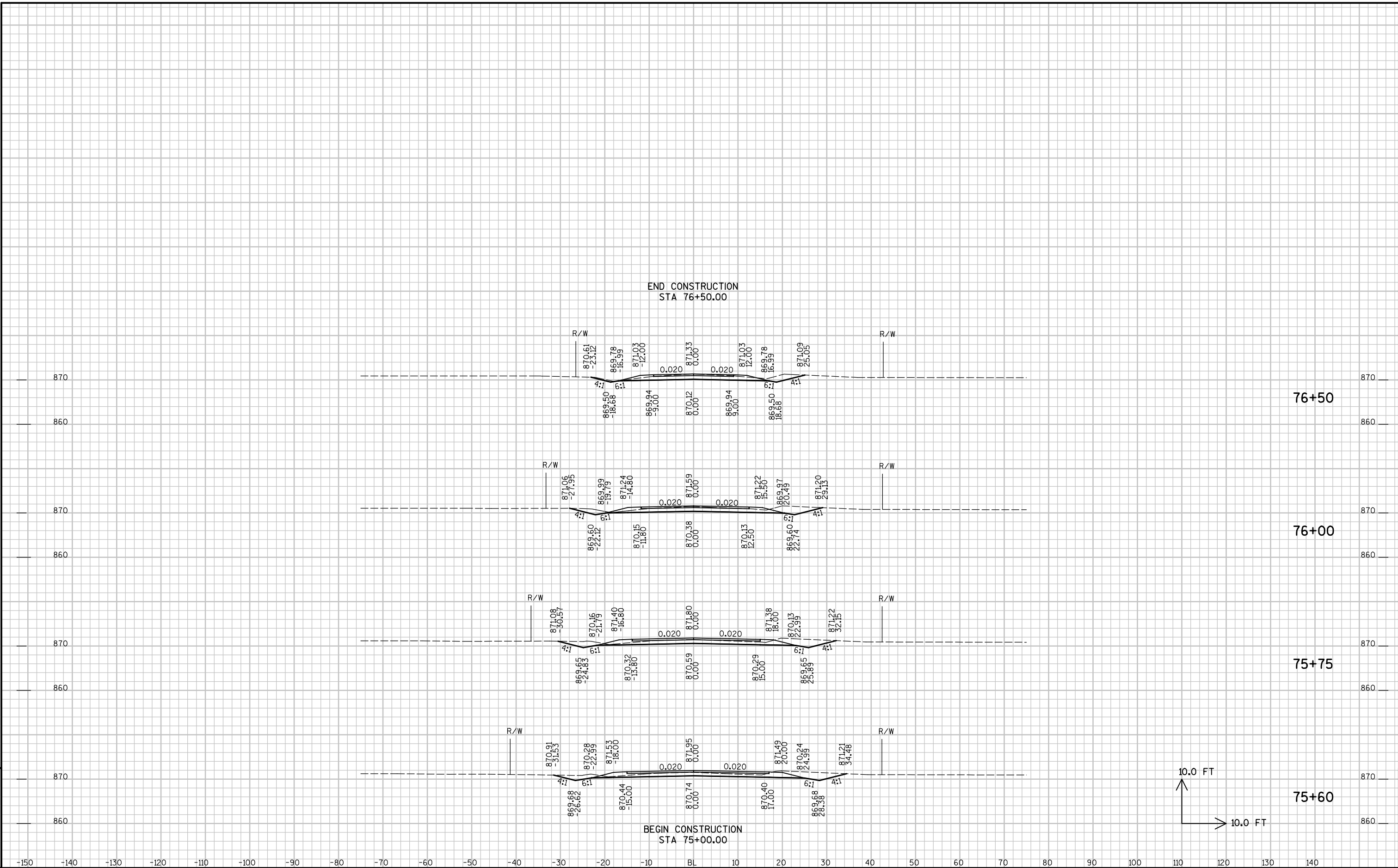

9

9

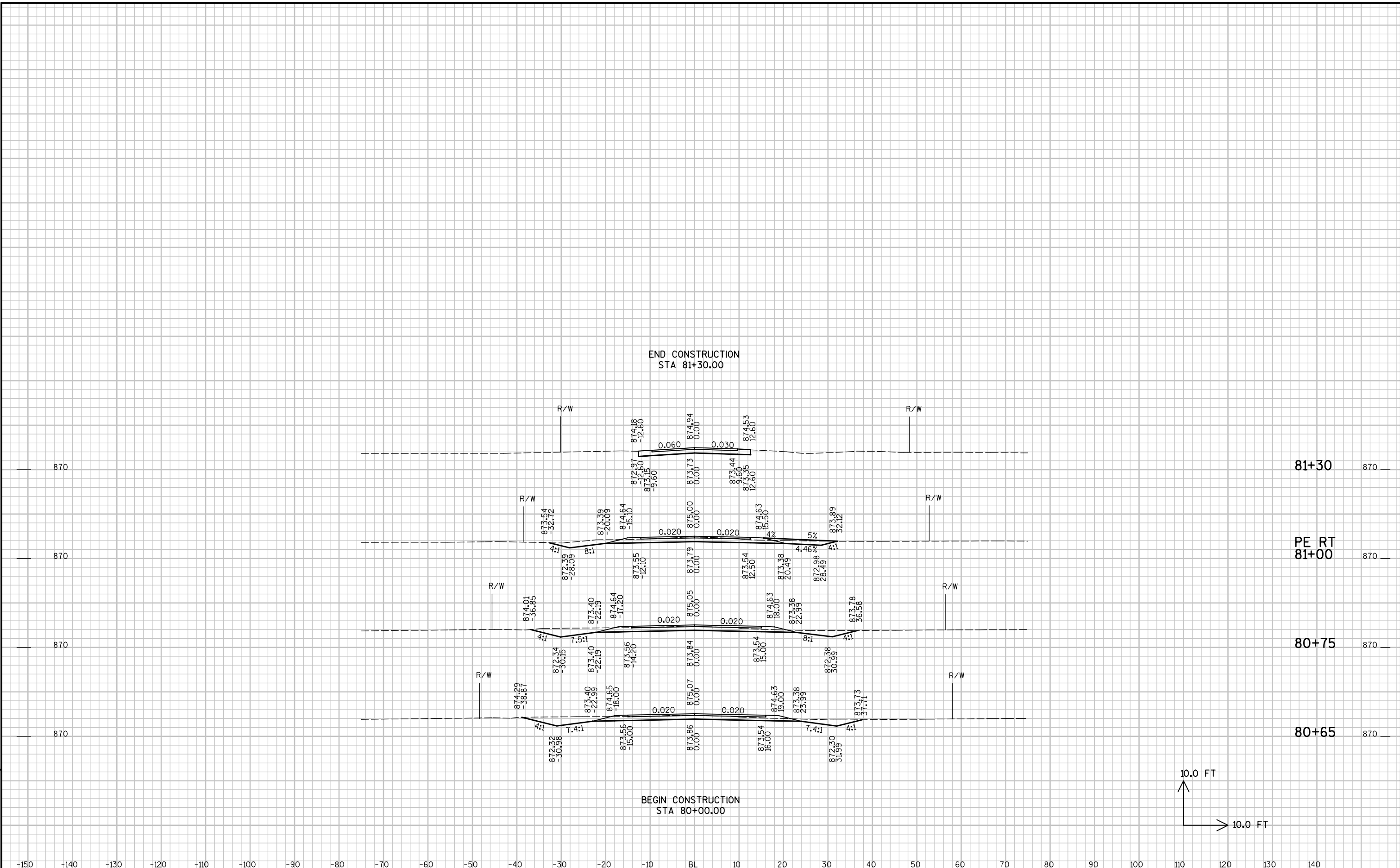

9

9

PROJECT NO : 6355-00-74	HWY : CTH Z	COUNTY : ADAMS	CROSS SECTIONS - EAGLE COURT	SHEET NO:	E
-------------------------	-------------	----------------	------------------------------	-----------	---

FILE NAME : X:\AE\ADAMC\157311\5-final-dsgn\51-drawings\CAD\cad\XB13eaglecourt.dgn PLOT TIME : 7:37:58 AM PLOT DATE : 2/9/2021 PLOT BY : SEH INC PLOT NAME : PLOT SCALE : Invalid expression

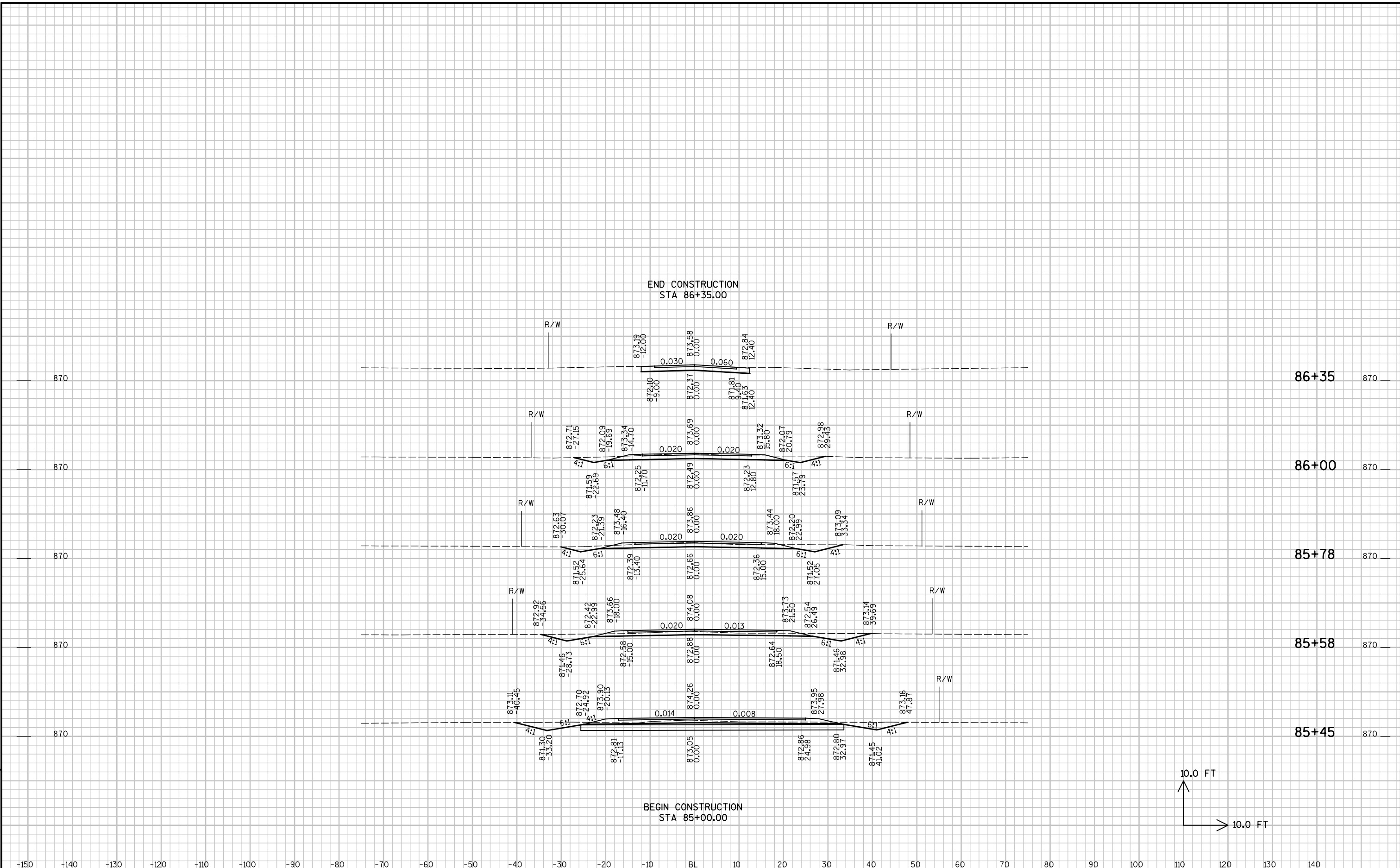

END CONSTRUCTION
STA 86+35.00

BEGIN CONSTRUCTION
STA 85+00.00

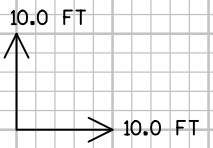

9

9

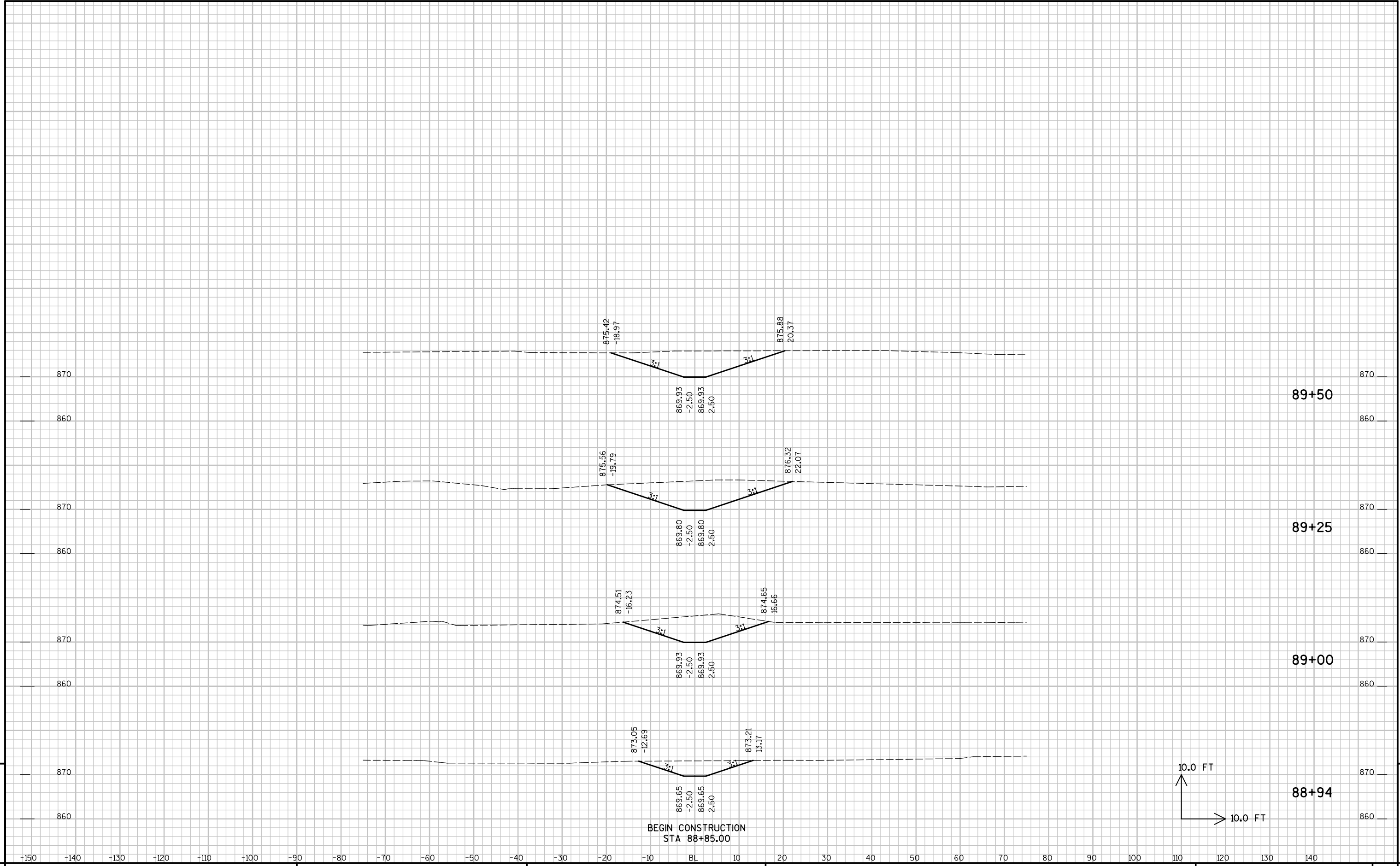

BEGIN CONSTRUCTION
STA 88+85.00

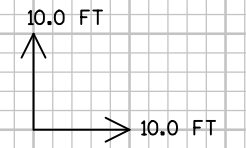

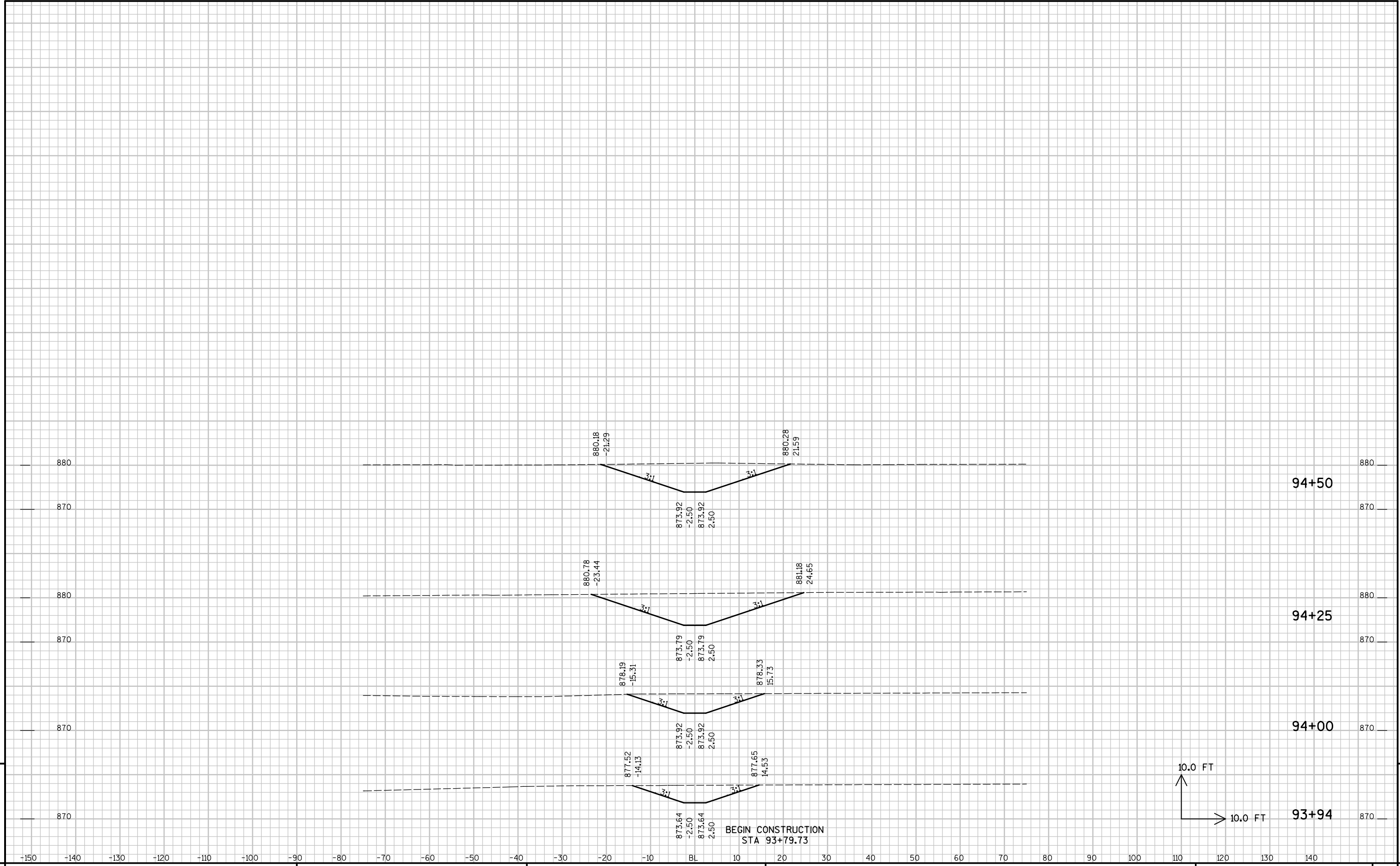

9

9

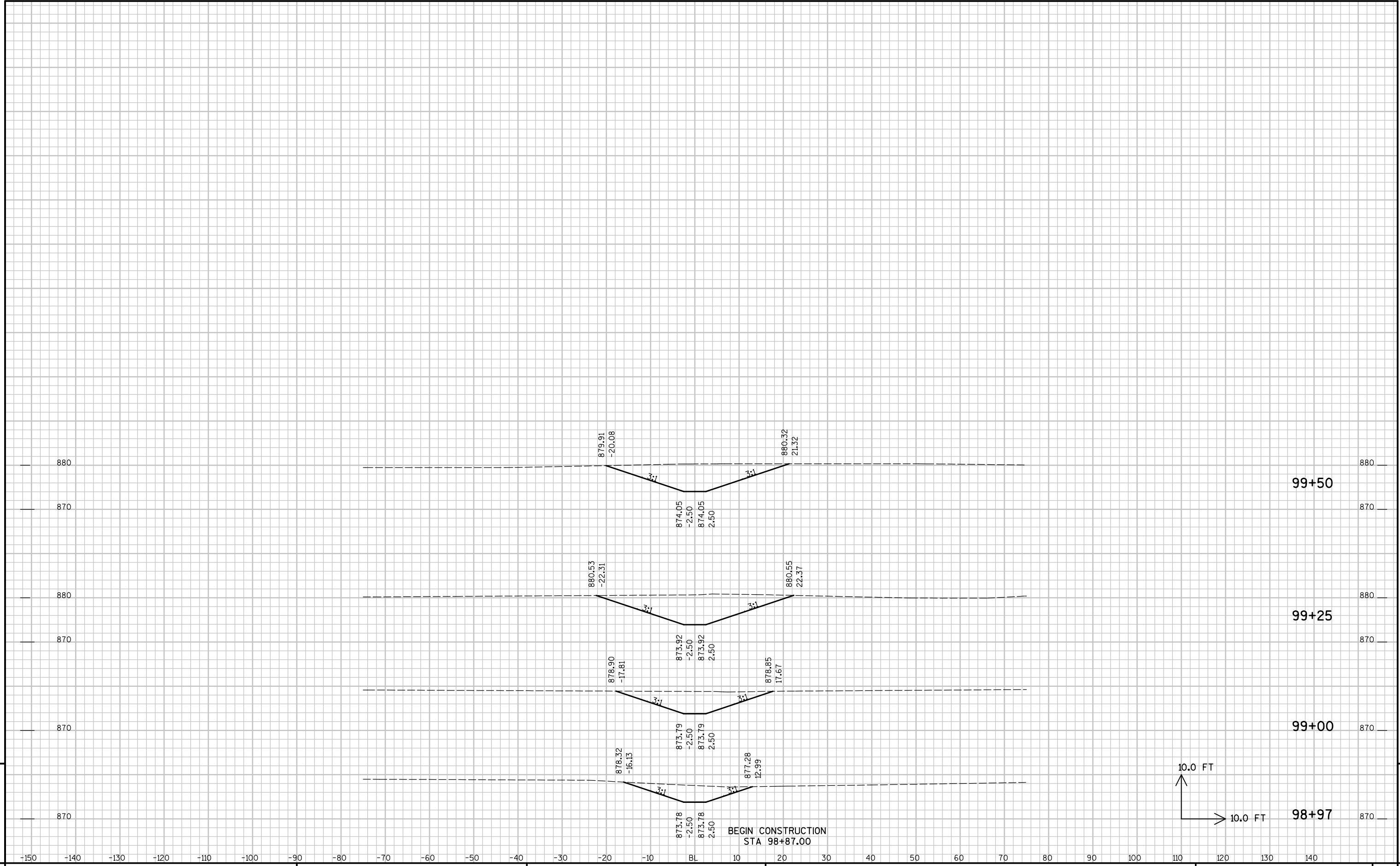

9

9

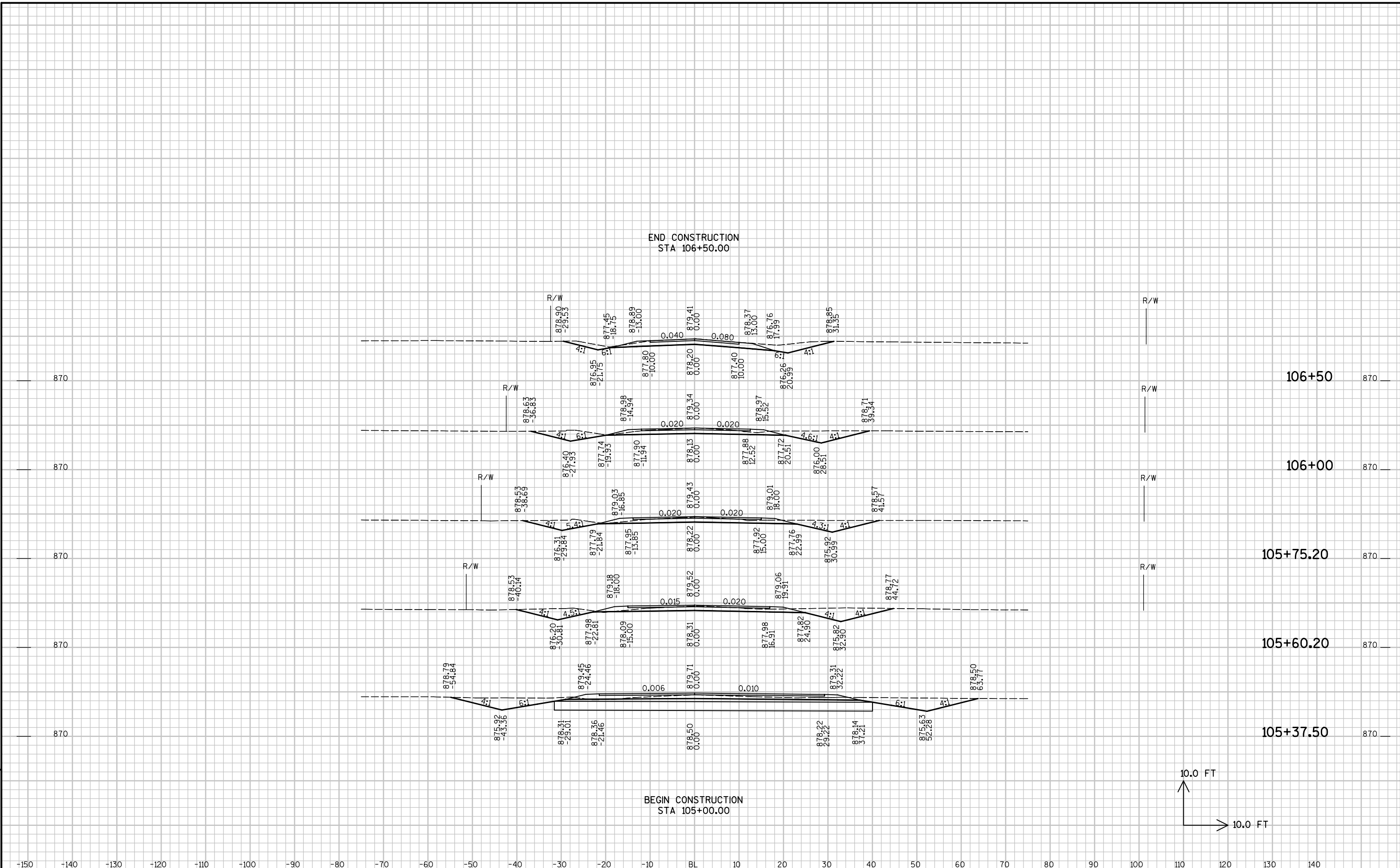

9

9

END CONSTRUCTION
STA 111+65.00

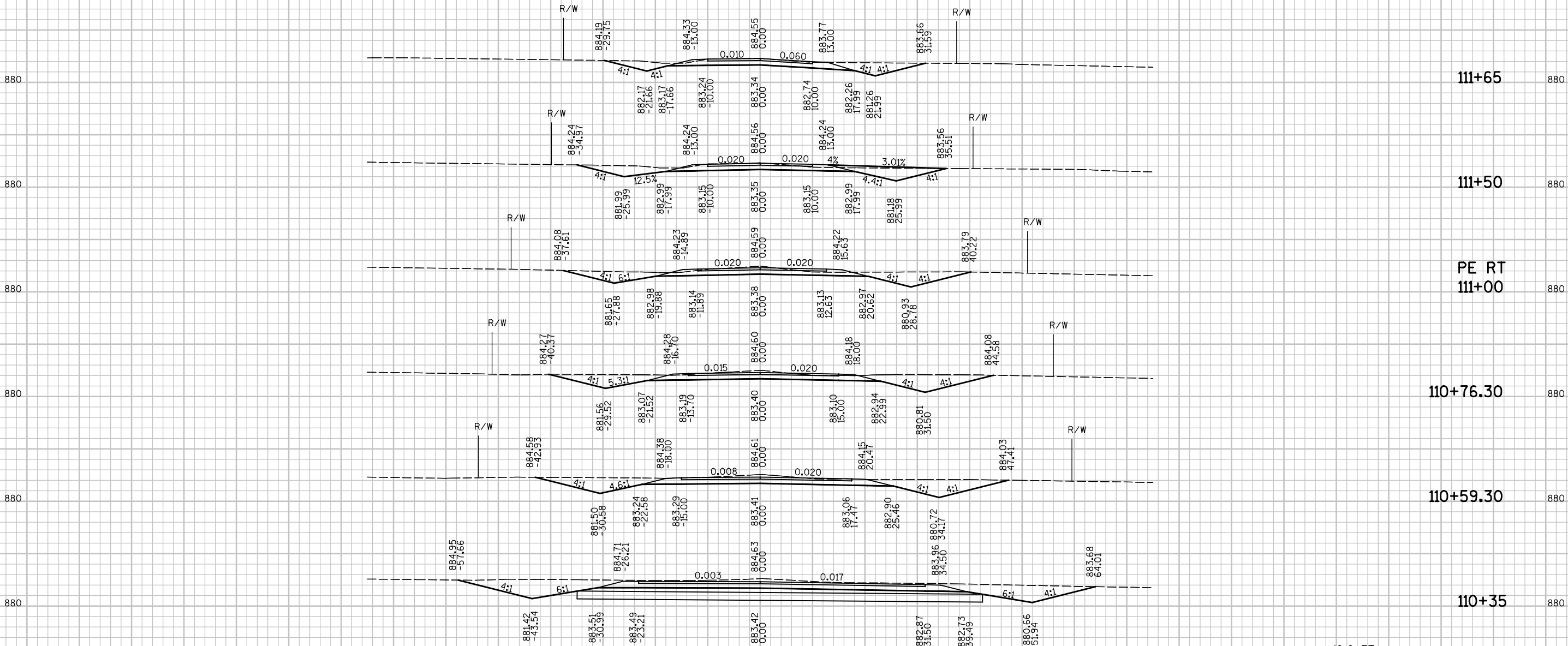

BEGIN CONSTRUCTION
STA 110+00.00

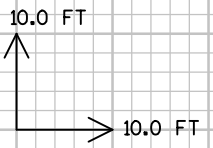

9

9

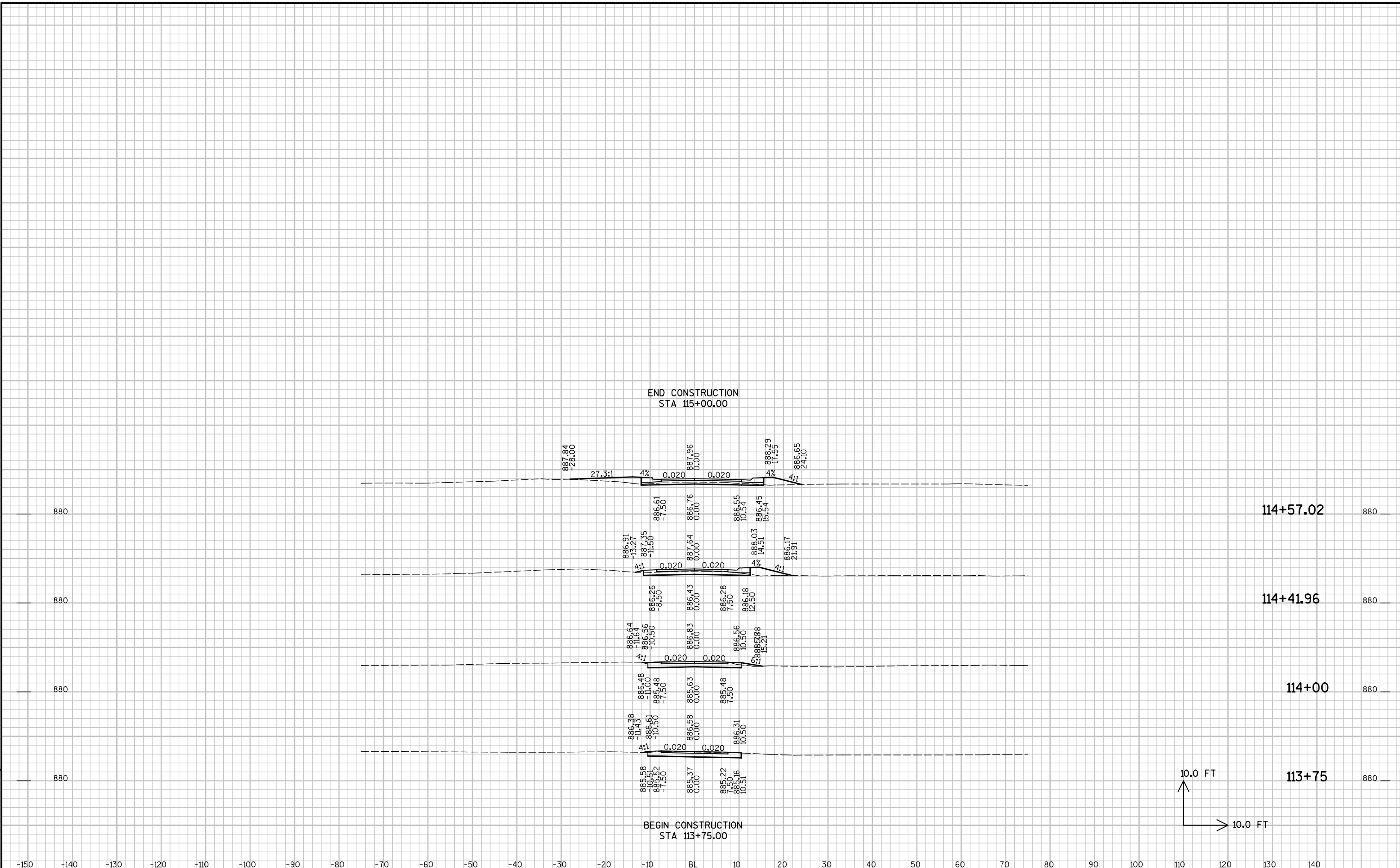

9

9

PROJECT NO : 6355-00-74	HWY : CTH Z	COUNTY : ADAMS	CROSS SECTIONS - PARK EXIT	SHEET NO:	E
-------------------------	-------------	----------------	----------------------------	-----------	---

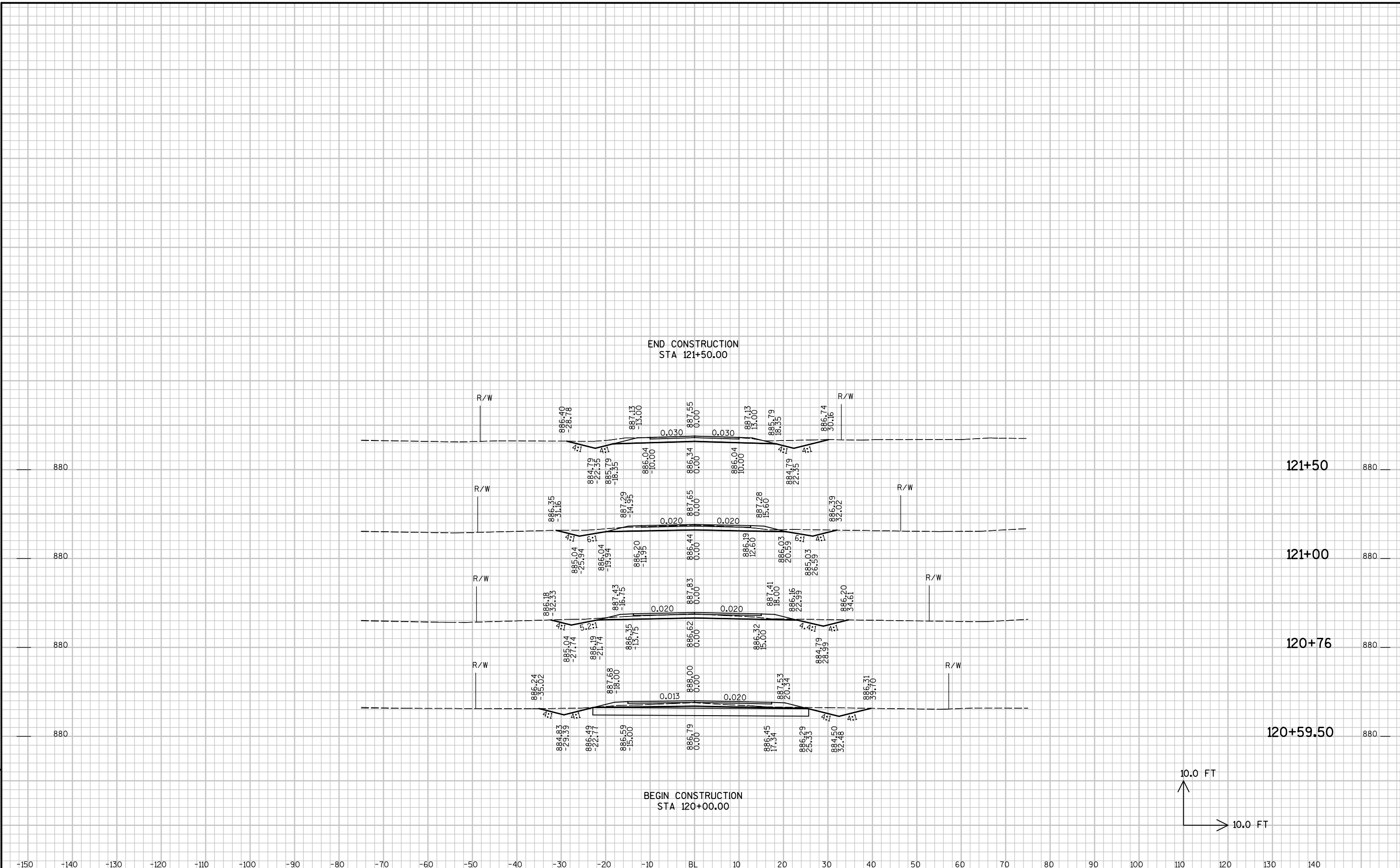

9

9

END CONSTRUCTION
STA 125+00.00

BEGIN CONSTRUCTION
STA 123+50.00

124+49.39

124+38.11

124+00

123+50

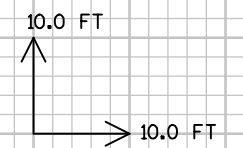

-150 -140 -130 -120 -110 -100 -90 -80 -70 -60 -50 -40 -30 -20 -10 BL 10 20 30 40 50 60 70 80 90 100 110 120 130 140

PROJECT NO : 6355-00-74

HWY : CTH Z

COUNTY : ADAMS

CROSS SECTIONS - PARK ENTRANCE

SHEET NO:

E

FILE NAME : X:\AE\A\ADAMC\157311\5-final-dsgn\51-drawings\CAD\cad\XB19parkentrance.dgn

PLOT TIME : 7:38:36 AM

PLOT DATE : 2/9/2021

PLOT BY : SEH INC

PLOT NAME :

PLOT SCALE : Invalid expression

9

9

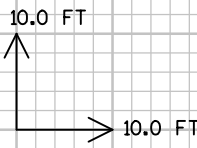
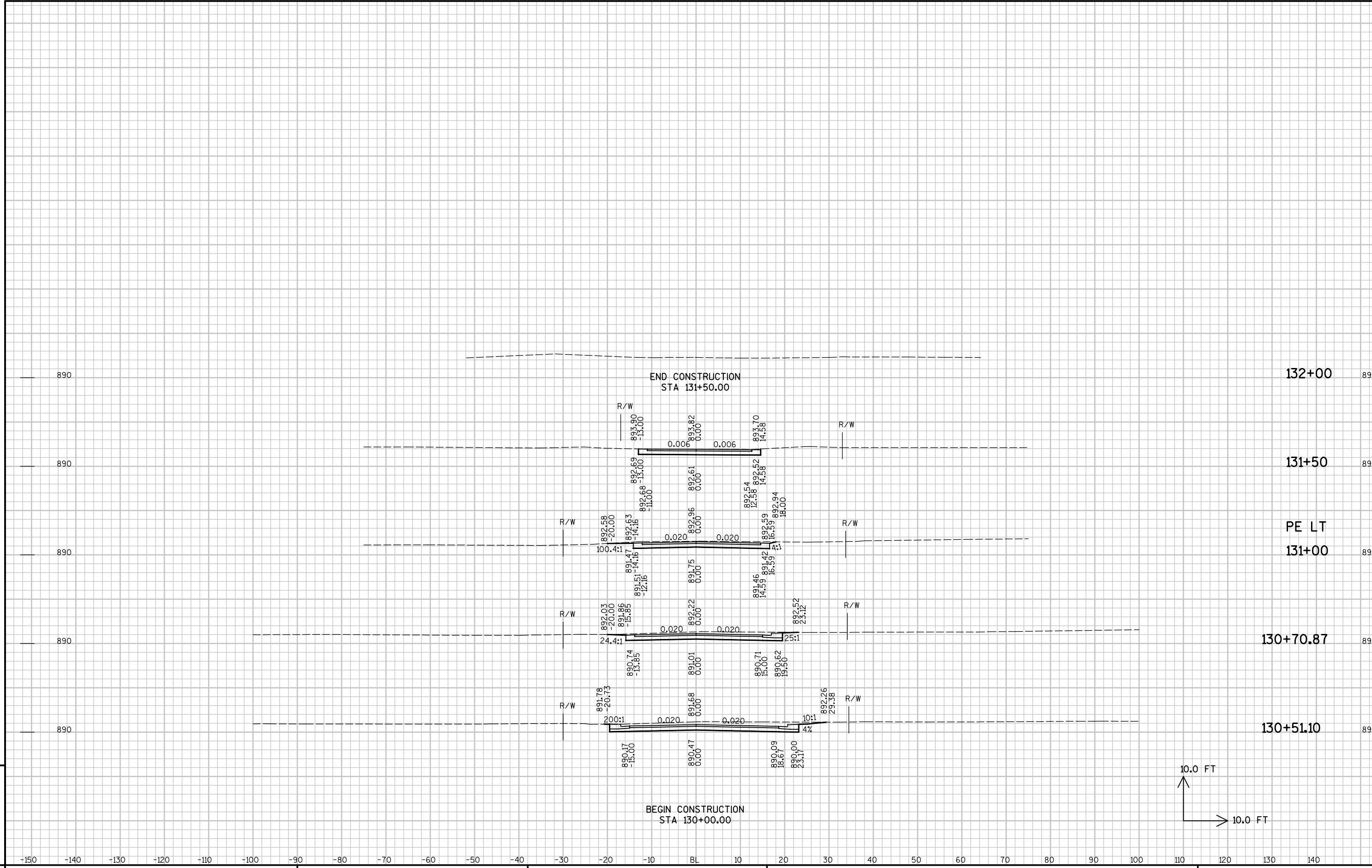

9

9